



ELECTRONIC ENGINEERING LTD.

# Runner Series

WIRELESS AND WIRED CONTROL PANEL

## Installation and Configuration Guide

by CROW Electronic Engineering Ltd.

## **IMPORTANT NOTICE**

All information and data contained in this document is proprietary and confidential. CROW Electronic Engineering Ltd. shall not be liable, in any event, for any claims for damages or any other remedy in any jurisdiction whatsoever, whether in an action in contract, tort (including negligence and strict liability) or any other theory of liability, whether in law or equity including, without limitation, claims for damages or any other remedy in whatever jurisdiction, and shall not assume responsibility for patent infringements or other rights to third parties, arising out of or in connection with this document. Further, CROW Electronic Engineering Ltd. reserves the right to revise this publication and to make changes to its content, at any time, without obligation to notify any person or entity of such revision changes. These materials are copyrighted and any unauthorized use of these materials may violate copyright, trademark, and other laws. Therefore, no part of this publication may be reproduced, photocopied, stored on a retrieval system, or transmitted without the express written consent of CROW Electronic Engineering Ltd. Any new issue of this document invalidates previous issues.

**©CROW Electronic Engineering Ltd. 2005, 2006. All rights reserved.**

Information in this document is subject to change without notice. No part of this document may be reproduced or transmitted in any form or by any means, electronic or mechanical, without express written permission of CROW Electronic Engineering Ltd..

**Document Version 1.00.013**

**Runner Series**

**January 2006**

# CONTENTS

---

<b>OVERVIEW</b> .....	<b>6</b>
CONNECTION DIAGRAMS .....	6
<b>INPUT OPTIONS</b> .....	<b>8</b>
DIFFERENT INPUT CONFIGURATIONS .....	9
ZONE WIRING EXAMPLES.....	10
OTHER INPUTS .....	12
<b>OUTPUTS</b> .....	<b>13</b>
DESCRIPTION OF OUTPUTS .....	13
KEYPAD PORT.....	13
EXPANSION PORT .....	14
<b>ACCESSORIES</b> .....	<b>15</b>
RADIO RECEIVER.....	15
VOICE BOARD.....	15
PROXIMITY READERS.....	16
PROXIMITY READERS CONNECTIONS.....	17
NIGHT MONITOR KEYPAD .....	18
<b>KEYPAD INDICATORS</b> .....	<b>20</b>
LED KEYPAD.....	20
LCD KEYPAD.....	25
<b>KEYPAD ADDRESS ASSIGNMENT &amp; INSTALLATION</b> .....	<b>27</b>
LED KEYPAD.....	27
LCD KEYPAD.....	28
ADJUSTING BACKLIGHTING AND BUZZER TONE.....	29
<b>LCD KEYPAD "LOCAL EDIT" MODE</b> .....	<b>30</b>
LCD KEYPAD.....	30
<b>PROGRAM MODE ACCESS</b> .....	<b>37</b>
ACCESSING PROGRAM MODE .....	37
EXITING PROGRAM MODE.....	38
<b>SPECIAL KEYPAD FUNCTIONS</b> .....	<b>48</b>
ARMING OR DISARMING TWO AREAS AT A KEYPAD .....	48
LCD QUICK VIEW MODE .....	48

TOGGLE CHIME MODE ON/OFF .....	49
SEND MANUAL TEST CALL .....	49
MANUALLY ANSWER AN INCOMING CALL .....	49
<b>PROGRAMMING USERS .....</b>	<b>50</b>
USER CODES .....	50
USER CODE TYPE .....	51
USER AREAS .....	51
USER ACCESS OPTIONS.....	52
USER CODE PRIVILEGES - USER PROGRAM OPTIONS .....	53
RADIO USER TYPE - PENDANT TYPE.....	53
RADIO USER PRIVILEGES – PENDANT OPTIONS.....	54
USER TIME ZONE ASSIGNMENTS.....	54
USER TO KEYPAD ASSIGNMENT – USER DEVICES .....	55
RADIO PENDANT PANIC BEEPS TO KEYPAD .....	55
USER TO OUTPUT MASK .....	55
USER CAN TURN AN OUTPUT ON AND OFF .....	56
RADIO PENDANT PANIC ALARM TO OUTPUT.....	56
LEARN FIND AND DELETE RADIO KEY CODES AND TAGS .....	57
<b>MISCELLANEOUS PANEL &amp; CLOCK SETTINGS .....</b>	<b>59</b>
INSTALLER CODE.....	59
DURESS DIGIT.....	59
DIAL REPORTING DELAY.....	59
RADIO ZONE SUPERVISED TIMER.....	59
TWO TRIGGER TIMER .....	60
MAINS FAIL REPORTING DELAY .....	60
RECEIVER FAIL DELAY/TIMER .....	60
UPLOAD/DOWNLOAD SITE CODE NUMBER .....	60
TEMPORARY OUTPUT DISABLE .....	60
MISCELLANEOUS INSTALLER AND PANEL OPTIONS.....	61
HIDE USER CODES - USER OPTIONS .....	62
SETTING TIME, DATE AND DAYLIGHT SAVING .....	63
DAYLIGHT SAVING (DLS) SETTINGS .....	63
<b>OUTPUTS.....</b>	<b>64</b>
OUTPUT OPTIONS .....	64
OUTPUT ON DELAY, PULSE, RESET AND CHIME TIMES .....	66
OUTPUT VOICE BOARD REMOTE CONTROL START MESSAGES.....	67
UN-MAP AN OUTPUT .....	67

ASSIGNING A TIME-ZONE TO AN OUTPUT .....	67
<b>AREAS .....</b>	<b>68</b>
AREA ARM AND SPECIAL FUNCTION OPTIONS .....	68
AREA ARM/STAY PULSE & CHIRPS TO OUTPUTS .....	70
MONITORING ACCOUNT CODE NUMBER .....	74
REMOTE ARM/DISARM DTMF CODE & START VOICE MESSAGE .....	74
AREA DELINQUENCY DELAY .....	75
AUTOMATIC ARM/DISARM TIME ZONE .....	75
<b>KEYPADS .....</b>	<b>76</b>
KEYPAD AREA ASSIGNMENT .....	76
KEYPAD BUTTON OPERATIONS, MISC. BEEPS AND LED CONTROL .....	76
KEYPAD ARM, STAY, A AND B BUTTON OPTIONS .....	78
KEYPAD TO OUTPUT MASK .....	82
<CONTROL> BUTTON TO OUTPUT MASK .....	82
KEYBOARD PANIC, FIRE AND MEDICAL ALARMS TO OUTPUTS AND KP BUZZER .....	83
KEYPAD CHIME TIMER .....	85
PROXIMITY READER OPTIONS .....	85
<b>KEY-SWITCHES .....</b>	<b>87</b>
KEY-SWITCH AREA ASSIGNMENT .....	87
KEY-SWITCH ARM/DISARM OPTIONS .....	87
<b>ZONES .....</b>	<b>89</b>
ZONE AREA ASSIGNMENT .....	89
ZONE ALARM TYPE OPTIONS .....	89
ZONE EOL (END-OF-LINE) OPTIONS AND VIBRATION SETTINGS .....	92
RADIO ZONE DETECTOR TYPE .....	93
ZONE ALARMS TO OUTPUT AND KEYBOARD BUZZER MAPPING .....	95
ZONE CID REPORT CODES .....	99
ARMED AND STAY MODE ENTRY DELAY TIMES .....	100
ZONE WATCH DOG TIMER .....	100
LEARN/FIND AND DELETE RADIO ZONE CODES .....	101
<b>TIME ZONES .....</b>	<b>102</b>
HOLIDAYS .....	102
TIME ZONE DAYS .....	102
TIME ZONE START AND STOP TIMES .....	103
<b>DIALLER .....</b>	<b>104</b>
DIALLER OPTIONS .....	104

AUTO ANSWER RING COUNT.....	105
TEST CALL OPTIONS.....	106
KEYPAD LISTEN-IN AND OUTPUT OPTIONS.....	106
DIALLING PRE-FIX NUMBER .....	107
KEYPAD PANIC, FIRE AND MEDICAL ALARMS CID REPORT CODE.....	107
OUTPUT, MICROPHONE & VOICE KISS OFF DTMF REMOTE CODES.....	107
MISCELLANEOUS VOICE REPORTING MESSAGE NUMBERS .....	109
<b>TELEPHONE NUMBERS .....</b>	<b>110</b>
PROGRAMMING TELEPHONE NUMBERS.....	110
REPORTING FORMATS.....	110
TELEPHONE NUMBER REPORT OPTIONS .....	111
MAXIMUM DIAL RE-TRIES PER TELEPHONE NUMBER .....	112
DIAL PROGRESS OPTIONS.....	112
CALL DIVERT NUMBERS & OPTIONS .....	115
CALL DIVERT NUMBERS & OPTIONS .....	116
<b>4+2 PROGRAM OPTIONS.....</b>	<b>117</b>
USING THE 4+2 CODES .....	117
MAINS/BATTERY/TAMPER/DURESS & ARMING 4+2 CODES.....	118
<b>DIAGNOSTIC &amp; DEFAULT OPTIONS.....</b>	<b>120</b>
DISPLAY SOFTWARE VERSION, KEYPAD NUMBER AND KEYPAD AREAS.....	120
DISPLAY ACTIVE TIME ZONES & BATTERY VOLTAGE .....	120
START WALK TEST MODE .....	120
READ OR WRITE TO THE DTU .....	121
RESTORE DEFAULTS .....	121
CLEAR MEMORY BUFFER.....	121
START A CALL-BACK CALL.....	121
<b>USER PRIVILEGES CHART .....</b>	<b>122</b>
TELECOM INTERFACE.....	123
<b>CONTACT ID CODE SUMMARY .....</b>	<b>125</b>
<b>SOFTWARE CHANGE UPDATE NOTICE.....</b>	<b>127</b>
<b>PW8/16 QUICK START GUIDE.....</b>	<b>128</b>
<b>PW8/16 CONFIGURATION SUMMARY GUIDE .....</b>	<b>130</b>
USERS .....	131
MISCELLANEOUS PANEL & CLOCK SETTINGS.....	135
OUTPUTS .....	137
AREAS .....	139

---

KEYPADS.....	142
KEY-SWITCHES.....	148
ZONES.....	148
TIME ZONES .....	156
DIALLER.....	157
TELEPHONE NUMBERS.....	159
MISCELLANEOUS 4+2 PROGRAM OPTIONS.....	162
PANEL DIAGNOSTIC & DEFAULT OPTIONS.....	163
CROW ELECTRONIC ENGINEERING LTD. (Crow) WARRANTY POLICY CERTIFICATE .....	164
<b>HOW TO CONTACT US.....</b>	<b>165</b>

# Overview

## Connection Diagrams

### Runner 8

The Runner 8 board is installed in three different enclosures:

- ❑ PW-housing
- ❑ COMPACT housing - has a 20VA transformer
- ❑ MINI-housing – has a 25VA transformer

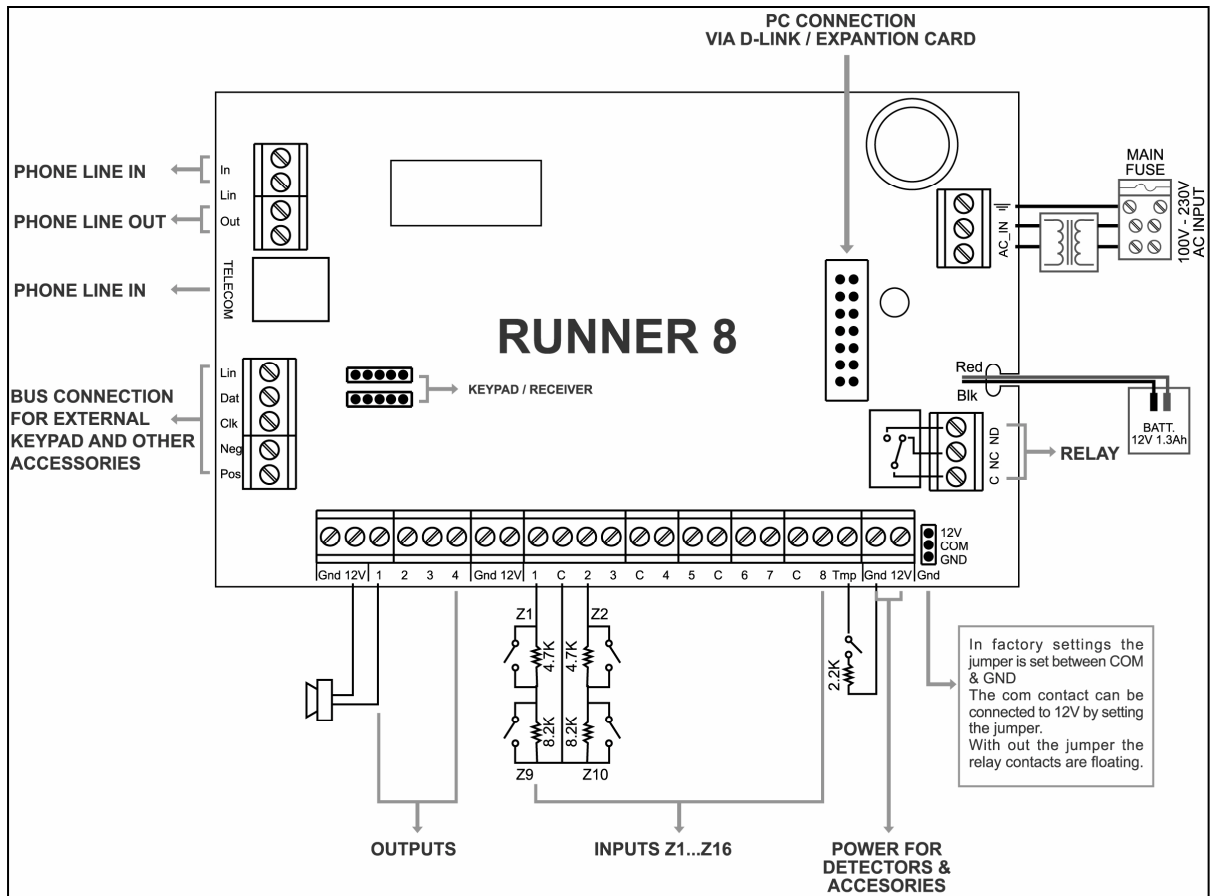

**Battery Spec.:** Sealed Lead-Acid Rechargeable Battery 12V/1.3Ah up to 12V /7Ah in the Mini and PW-housings.

**Battery Cutoff Level:** (When AC mains fails) : 7V to 7.6 V.

## Runner Plus

The Runner Plus board is installed inside the Compact Box and together with a 20VA transformer.

The Runner Plus can also be powered from an external adaptor 100-240V AC /14.4V DC ,1A. According to customer request.

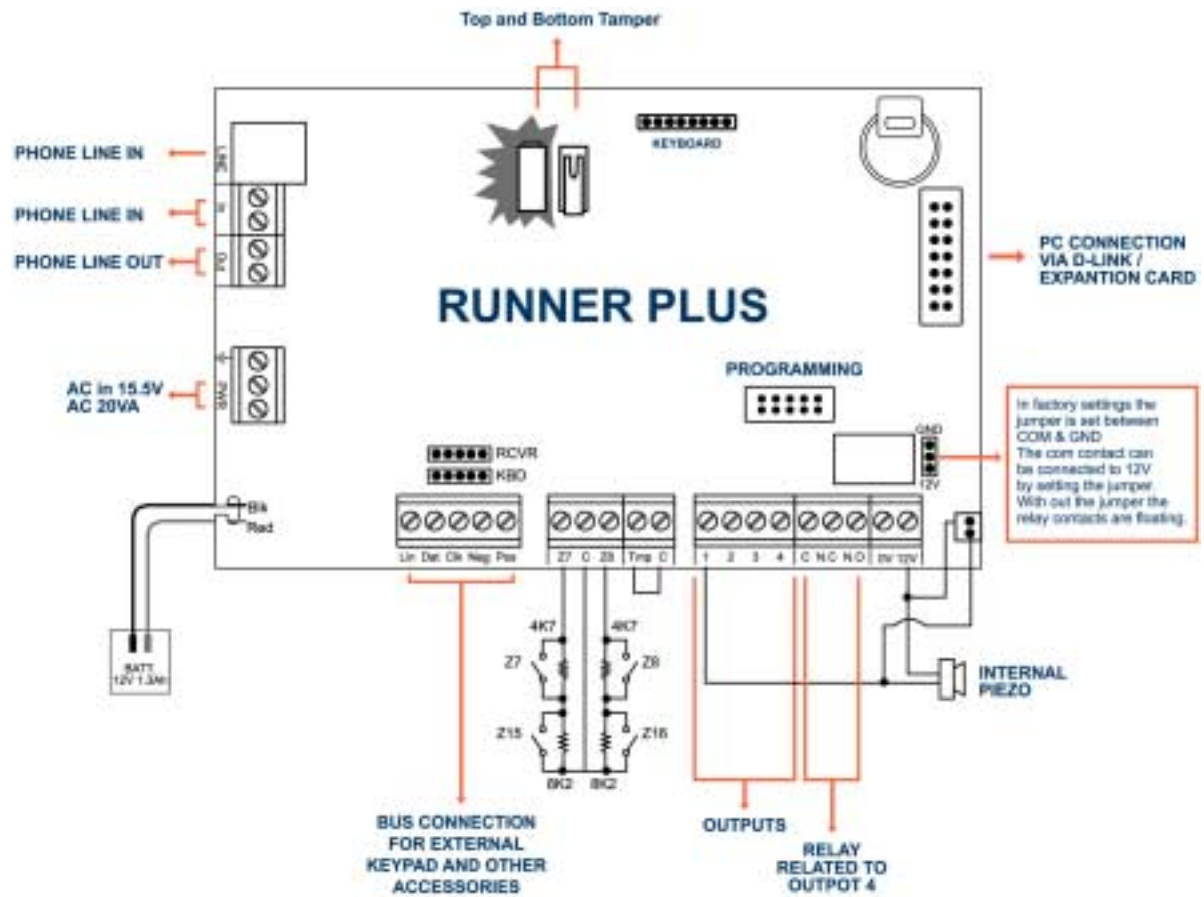

**Battery Spec.:** Sealed Lead-Acid Rechargeable Battery 12V/1.3Ah.

**Battery Cutoff Level :** (When AC mains fails) : 7V to 7.6 V

## Runner 16

The Runner 16 board is installed in PW-housing with transformer 33VA

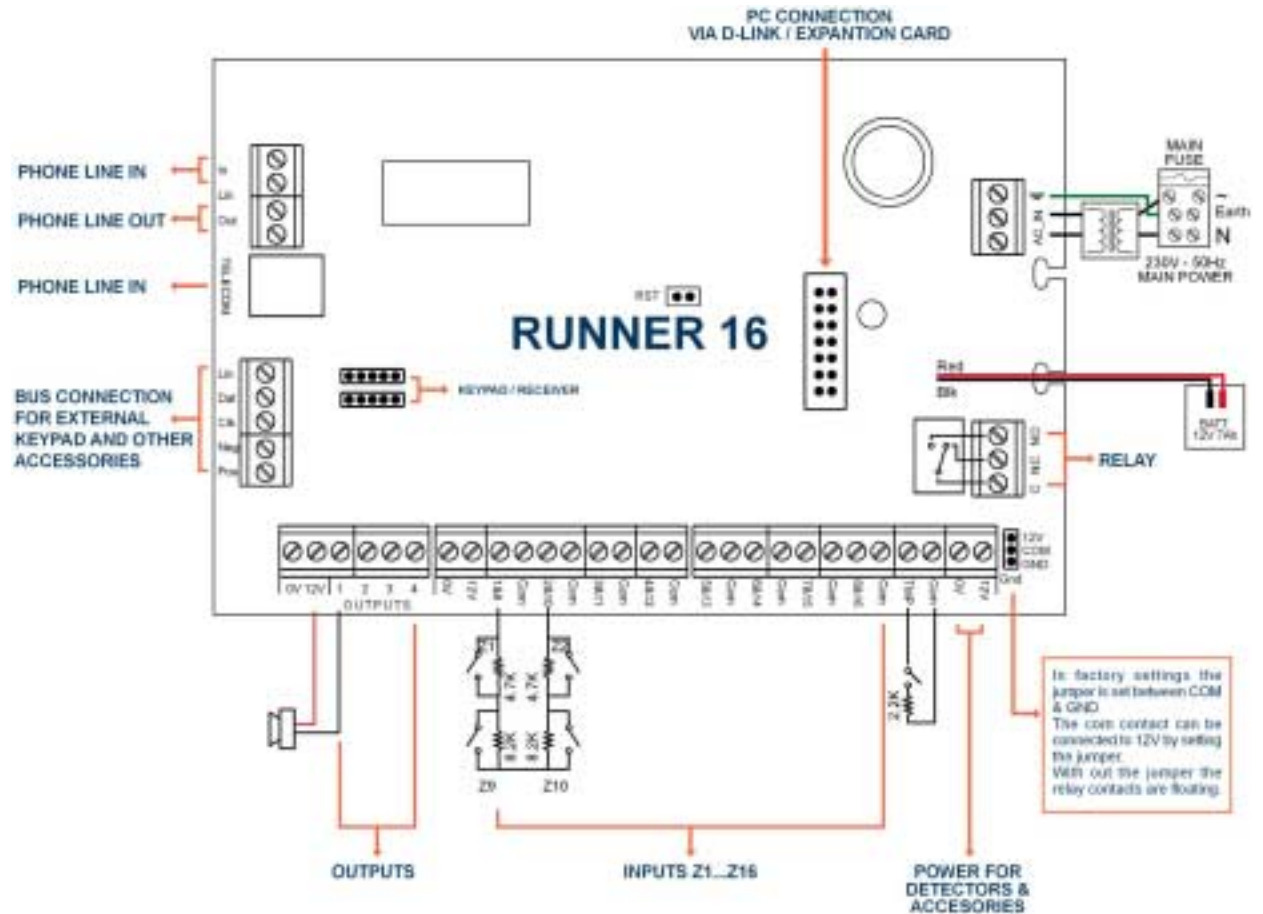

**Battery Spec.:** Sealed Lead-Acid Rechargeable Battery up to 12V /7Ah **Battery Cutoff Level:** (When AC mains fails) : 7V to 7.6 V.

# Input Options

## Different Input Configurations

The Runner 8 has nine separate programmable monitored analogue inputs.

These are:

- ❑ Eight programmable multi-state detection inputs
- ❑ One programmable tamper input (with optional Key-switch functions)

The input connector block is located on the board.

### NOTE

**Each input must be terminated with the appropriate value or combination of End-Of-Line resistors, even if the input is unused.**

## Zone Inputs

Each of the Eight programmable zone inputs can be assigned one of the following End of Line (EOL) configuration options,

Zone EOL Type (P125E)	Input Resistor	Comments
0	(Short circuit)	Loop EOL
1	1k (Brown, Black, Red)	Single EOL
2	1k5 (Brown, Green, Red)	Single EOL
3	2k2 (Red, Red, Red)	Single EOL
4	3k3 (Orange, Orange, Red)	Single EOL
5	3k9 (Orange, White, Red)	Single EOL
6	4k7 (Yellow, Violet, Red)	Single EOL
7	5k6 (Green, Blue, Red)	Single EOL
8	6k8 (Blue, Grey, Red)	Single EOL
9	10k (Brown, Black, Orange)	Single EOL
10	12k (Brown, Red, Orange)	Single EOL
11	22k (Red, Red, Orange)	Single EOL
12	2k2 Tamper, 4k7 Zone	Zone & Tamper
13	3k3 Tamper, 6k8 Zone	Zone & Tamper
14	2k2 Tamper, 4k7 Low Zone, 8k2 High Zone	Zone Doubling with Tamper
15	4k7 Low Zone, 8k2 High Zone	Zone Doubling without tamper

## Zone Wiring Examples

### Type 0 (Short/Loop Circuit)

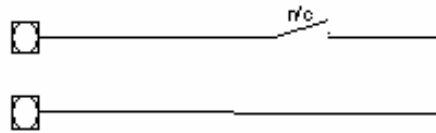

### Type 1-11 (Single EOL no Tamper)

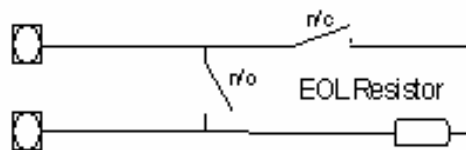

### Type 12-13 (Single Zone with Tamper)

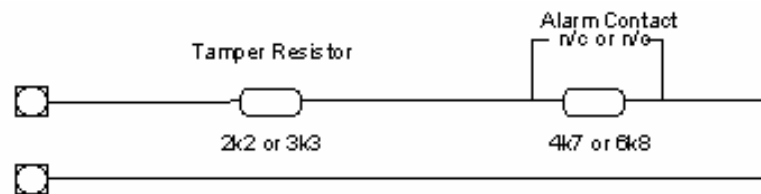

### Type 14 (Zone Doubling with Tamper)

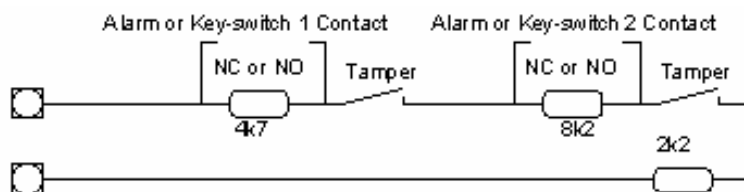

### Short circuit loop, No EOL

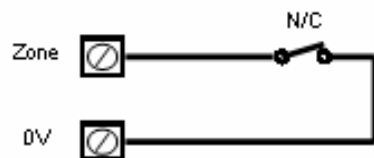

## 2k2 EOL, No Tamper

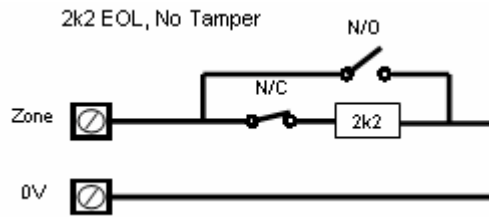

## Type 12 Configuration

Alarm & Tamper monitoring (contacts can be N/C or N/O).

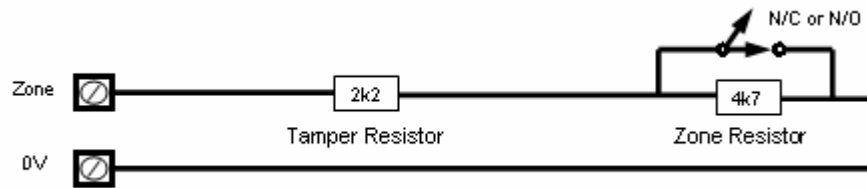

## Type 15 Configuration

Zone Doubling, NO Tamper (contacts can be N/C or N/O).

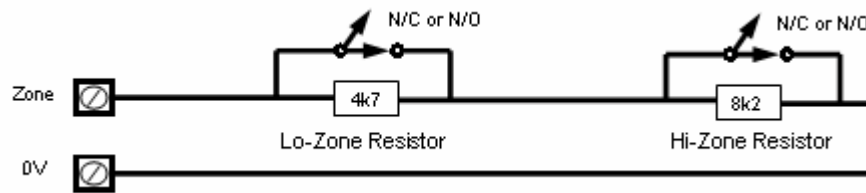

## Wiring a PIR Detector (N/C) for Alarm & Tamper Monitoring

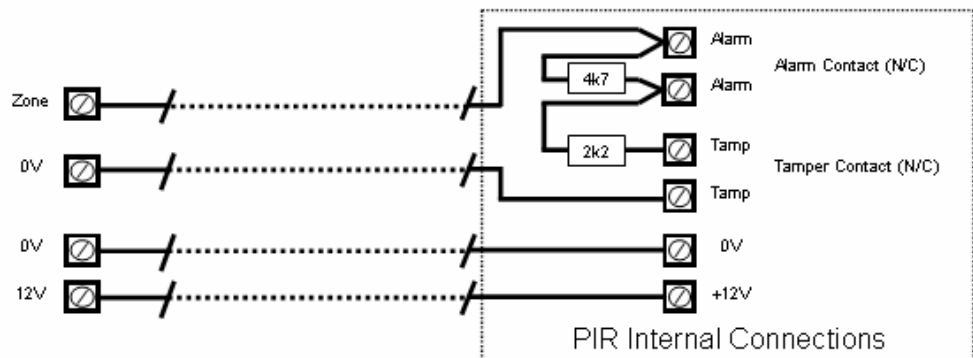

## Other Inputs

### Tamper

A 24Hr tamper circuit is available for monitoring system tampers. This Tamper circuit is programmable as either normally closed loop or 2k2 EOL supervision (the default is usually a closed loop). Any Tamper alarms on this input are mapped to alarm outputs in the same manner as for detection zones 1-16. Using Dual-End-of-Line resistors (Refer to Zone Type 15 on Page 9) the Tamper input can also provide two key-switches. The Low key-switch (4k7 resistor) is Key-switch 1 while the High key-switch (8k2 resistor) is Key-switch 2.

In addition to the Zone & Tamper inputs, you will find the following additional inputs on the control PCB;

### AC

Connect the two low voltage wires (no polarity) from the transformer to the terminals marked AC on the PCB. The panel includes a mains transformer rated at 15.5VAC.

### Earth - not used

In case of using metal box connect the mains earth to the appropriate terminal on the mains terminal block in the control box cabinet. Also connect a lead from this earth point to the terminal marked with the Earth symbol (next to AC terminals) on the panel PCB.

### Battery

Connect a sealed lead acid rechargeable 12VDC battery to the terminals labelled red and black on the control panel being careful to observe the correct polarity. The maximum recommended battery capacity is 7 amp hours. Battery charge current at these terminals is limited to 260mA maximum. The battery connection is protected against short circuits by a thermal fuse (F1). The panel performs a dynamic load test on the battery every 15 seconds and if it fails the test at any time it will flash the Battery LED.

### Line In

These terminals are used to connect the panel to the incoming telephone line. The dialler uses this line for reporting alarm events.

### Line Out

These terminals are used to connect telephones and other communication equipment to the incoming phone line via the panel dialler circuit. The telephone line is passed through the controller to ensure that the line is available to the controller when it is required.

# Outputs

## Description of Outputs

### 12 Volt Outputs

There are three 12VDC outputs on the panel PCB. These 12 volt outputs are regulated and Thermal fuse protected against short circuits. The accessory outputs are marked 12V and 0V, while the keypad buss 12V supply is labelled "POS" & "NEG". The 12V outputs are supplied by thermal fuses F2 & F3. The recommended maximum total load that should be drawn from all of the 12V outputs during an alarm is 1A.

### Outputs 1 & 2

These fully programmable, high current, open drain (high-going-low) type FET outputs capable of switching up to **1.5A @ 12VDC**. These 2 outputs are normally set as switched outputs, providing power for 12V sirens or piezos. If required, these outputs can be programmed to be siren outputs designed to drive an 8 ohm 10 watt horn speaker on each output (see P37E option 1). Also if a horn speaker is connected to **Output #1** you may select (Refer to P175E 7E program address) the listen-in feature to this output as well so that the dialling sequence can be heard at the speaker.

### Output 3 & 4

This is a low current, open drain (high-going-low) type FET outputs capable of switching up to **500mA**. Like Outputs 1 & 2 it is fully programmable.

#### NOTE

**Connecting devices which draw current in excess of 500mA to output 3/4 can damage the output.**

### Relay Out

This is a relay is related to **Output 4** with single pole changeover contacts. If required, the Common (C) contact of the relay is connected by default to GND via JUMPER, the jumper can be selected to 12V or removed.

## Keypad Port

The terminals marked *POS*, *NEG*, *CLOCK*, & *DATA* make up the communications port which the keypads and other intelligent field devices use to talk to the controller. The terminals are connected to corresponding terminals on the remote devices. The "**lin**" terminal is only used by the keypads and utilises a fifth wire to provide a communicator "**listen-in**" facility. This feature is particularly useful when servicing monitoring faults. The keypad 12V supply (*POS, NEG*) is protected by fuse F3.

## Expansion Port

The expansion port allows connection of the RS232 serial board, 90 second Voice Board, DTMF Board or EEPROM data transfer board (DTU). The serial board allows direct connection of a PC running the Upload/Download software. The 90 second voice board allows voice messages to be programmed for monitoring purposes. The Voice & DTMF boards allow Touchtone Code remote control via a telephone. The DTU allows for program "Cloning" from one panel to another.

# Accessories

## Radio Receiver

The panel can have wireless capability via the FW-RCVR receiver module. The receiver will add wireless capability to your system in the form of wireless PIR detectors, Wireless Radio-key transmitters and wireless reed switch transmitters.

The FW-RCVR connects to the same communications port as the keypads. The FW-RCVR is available in 3 frequencies, 915MHz,433MHz,868MHz. Multiple FW-RCVR can be connected to the panel to increase the coverage range if desired.

The green LED fitted to the FW-RCVR receiver will flash at 1 second intervals when in "Learn" mode (see P18E & P164E). The LED will also turn on when it is receiving an actual radio transmission (On Steady).

## Voice Board

The panel can also be fitted with a 90 second Voice Board module. The Voice board stores either alarm event messages for Voice dial monitoring and /or status messages for use with Command Control. The panel Voice Board are installed directly onto the motherboard via the SERIAL socket.

Installation procedure for the Voice Board module is as follows.

1. Power-down the panel fully before starting the installation procedure.
2. Carefully plug the Voice Board into the SERIAL socket (it will only fit in one direction).
3. Power-up the panel.

### Speech message programming

Once you have installed the Voice Board you can record your personalised speech messages into the module with the speech programmer (the programmer plugs onto the 10 way strip connector on the voice board).

Before programming your voice messages you should work out a list of the messages you would like to be sent for each alarm type and write them down in order, giving them a message number. These messages should then be recorded in the same order they are written down so you know what the message number is letter when programming alarms to messages.

To record your messages once the programmer is installed, first press the reset button on the side of the Voice Board, then hold the programmer about 10 cm away from the mouth and speak clearly at normal level into the microphone while holding down the "REC" button. When you reach the end of your message release the **REC** button. (**NOTE:** Each individual message must be longer than 2 seconds duration). When recording your voice alarm message, you must ensure that you clearly identify the origin of the call. You can play the message back through the programmer by first pressing the reset button then by pressing the "PLAY" button momentarily. Because the panel can address many individual voice messages you must store individual messages at what is known as recording slots within the Voice Board. These recording slots are recorded sequentially, one message starting where the other finishes. Every time you press and release the REC button on the programmer, you create an end of message marker. These markers are used to define the recording slots within the Voice Board and can be of varying length according to each message duration.

To re-record your messages you must first press the "RESET" button on the speech module to get back to recording slot # 1. Once you are at slot # 1 you can re-record your messages in order as required.

**NOTE**

**When recording multiple messages you only press the "RESET" button once at the beginning then record all messages sequentially as stated above. When you have finished recording all of your messages you can then press the "RESET" button to allow play-back of the recording messages for verification purposes.**

When you have finished recording your alarm messages, unplug the programmer and the process is complete. You must now go to the program addresses and assign the individual messages to the specific functions.

## Proximity Readers

There are three proximity readers that can be connected to the control panel. They are;

- PW-Reader 2K:** For arm/disarm area A and/or B.
- PW-Reader(without keys):** For arm/disarm one area A.
- PW-Reader FK :** Proximity and keypad (PIN) Access Reader.

The **PW-Reader 2K** is generally to be used for selective arming or disarming of either Area "A" or "B" or both. By presenting a valid access tag or card to the reader the user can then arm or disarm the panel using the "A" & "B" buttons on the reader. On presenting a valid tag to the reader, the current status of Areas A & B will be shown on the two LED's. The user has 4 seconds to make a new selection before the reader will timeout and the tag will have to be re-presented again. The Areas allowed to be controlled by the user must be programmed by the installer. If the User is allowed to fully Arm or arm Stay Mode then they can cycle through the various states (eg Disarmed, Full Armed, Stay Armed). As the "A" or "B" button is pressed the associated LED will change to indicate the new state, eg if the Disarmed state was selected the LED will be GREEN, If the Armed state was selected the LED will be RED and if Stay Mode was selected the LED would be flashing RED. Four seconds after the last button was pressed the reader will action the new armed status and the LED's will turn off. If the reader has also been programmed to allow the "1& 3 PANIC" function at that keypad number a "PANIC" alarm will be generated if the "A" & "B" buttons are pressed simultaneously (see P72E option 5).

**NOTE**

**From the disarmed state you can select Armed or Stay modes but if already Armed or in Stay Mode you MUST disarm first (letting the reader timeout) before you can select a new armed state.**

The **PW-Reader(without keys )** is generally going to be used as an access control reader although if the tag is allowed to Arm/Disarm the alarm then this will also happen when the tag is presented. For access control, if a tag or card is presented to the reader the associated door lock will release via an output on the control panel. There is also an output at the reader which can be used to unlock the door if desired (see drawing on following page for details). The output number at the reader follows the keypad address number, eg if the reader has been assigned to keypad address 5, the output at the reader will follow all programming associated with output 5.

The **PW-Reader FK** is generally going to be used as an access control reader as well although if the tag is allowed to Arm/Disarm the alarm then this will also happen when the tag is presented. This reader combines a proximity reader with a full keypad. Depending on program options the reader can be set-up to operate on a proximity tag or card only, on entering of a valid user code only, or on presentation of the tag/card followed by the user code (PIN). If the presented tag requires a PIN number to be entered, the LED on the reader

will flash for 5 seconds after a valid tag to indicate that the PIN number should now be entered. There is also an output available on this reader that follows the same addressing functionality as described above.

If the two button "PANIC", "FIRE" or "MEDICAL" functions are programmed to the keypad (see P72E Options 5,6 & 7) these manual alarms can be generated at the reader by pressing "1" & "2" for "PANIC", "3" & "4" for "FIRE" and "5" & "6" for "MEDICAL" alarms.

On each of the three readers there is an optional input (see drawings on following page). This input is not EOL monitored so it should only be used for non-critical monitoring functions, for example, monitoring an exterior gate to show if it is currently opened or closed. A zone can be programmed to use this input for its trigger (see P122E Option 4) so that the state of the input can be displayed on a keypad. The inputs are linked to the selected keypad address programmed into the reader. For example if the reader being used was programmed as keypad # 1, then the input can be assigned to zone 1 or 9 (at location P122E), if the keypad address was # 8, the input can then be assigned to zone 8 or 16.

Also, the LED on reader types 2 & 3 can be linked to an output so that special functions may be displayed at the reader if desired (see P98E).

Each reader must have a unique keypad address number from 1-8 assigned so that the various program options can be assigned. This is explained in detail on Page 90.

**NOTE**

**The proximity readers flash out the assigned keypad address number on the LED whenever the panel is in "Installer Program" Mode. This allows quick identification of the assigned address for each reader.**

## Proximity Readers Connections

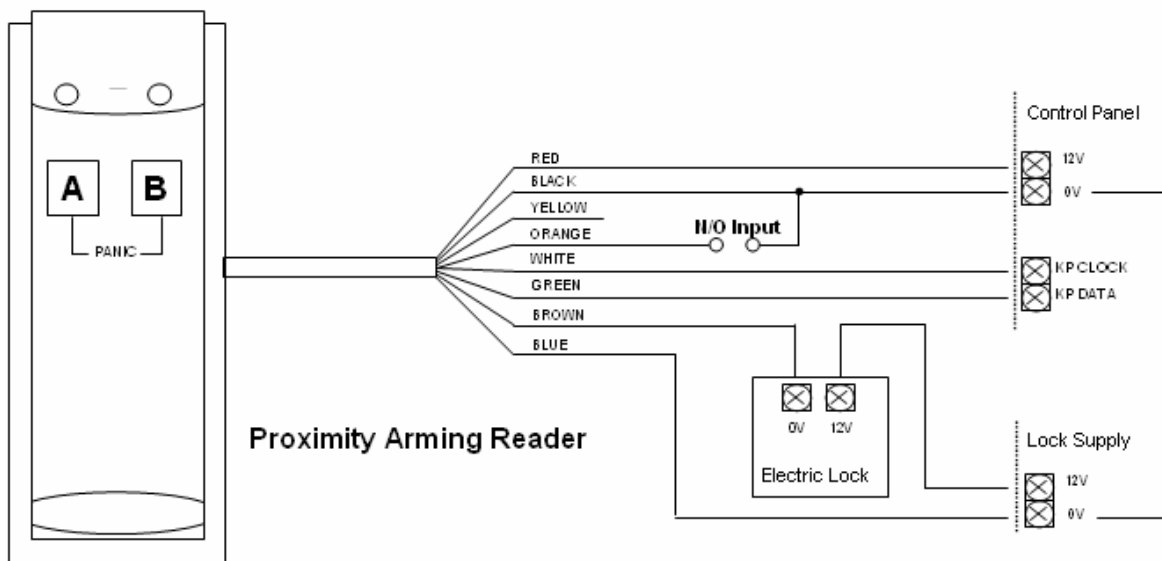

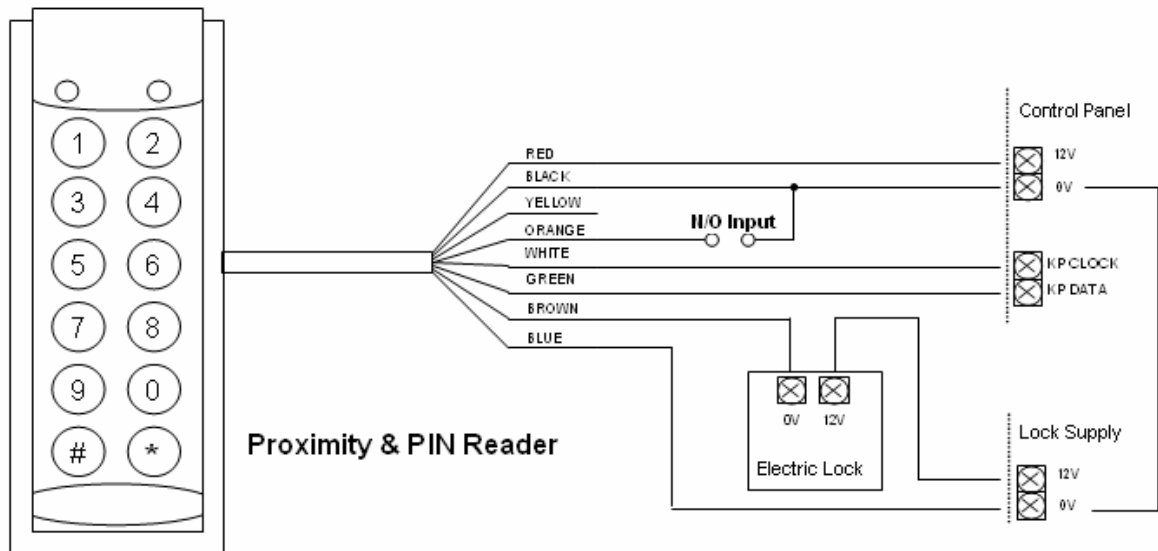
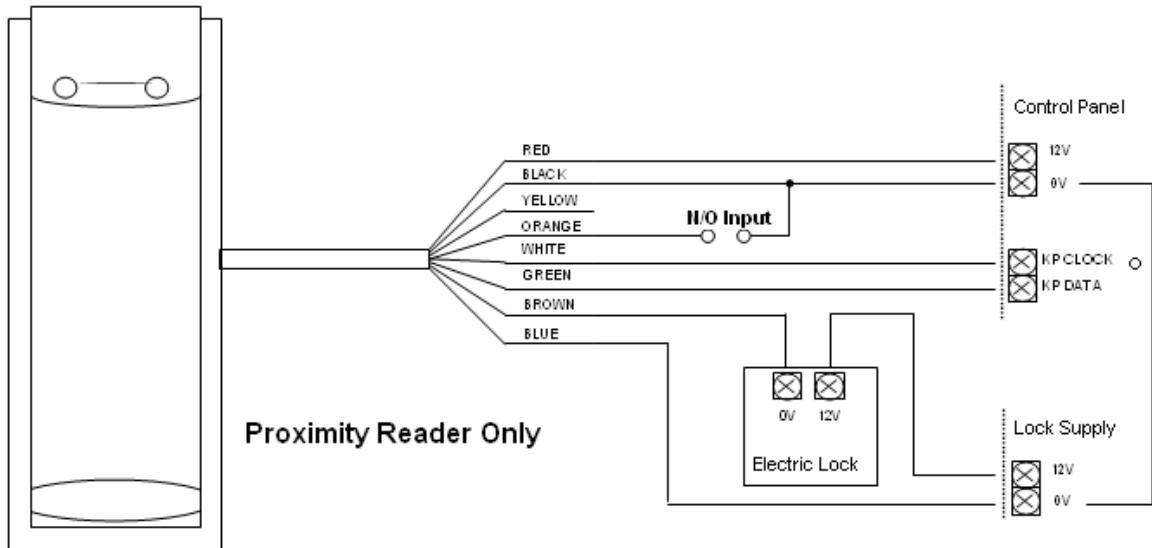

## Night Monitor Keypad

The Night Monitor Keypad is designed to be a simple night arming station typically used in a bedroom situation.

By pressing either of the <Night Monitor> buttons the alarm Stay Mode can be armed or disarmed. If both buttons are pressed simultaneously, a Panic Alarm can be generated. A 4 way DIP switch on the rear of the unit sets various options. The DIP switch functions and the programming requirements are detailed below.

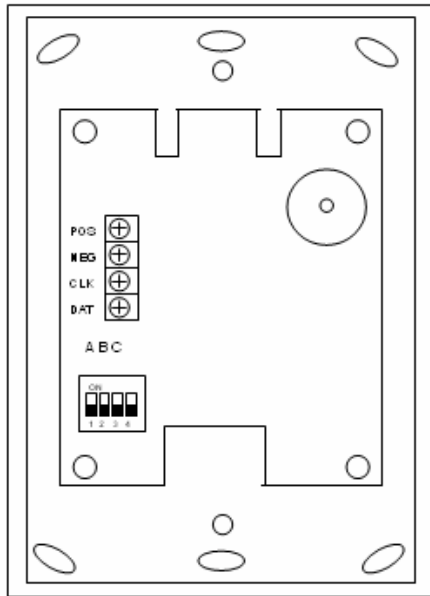

Rear View

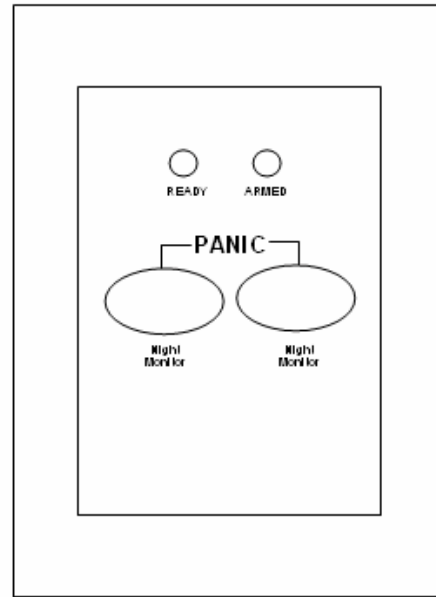

Front View

The Night Monitor keypad can be set to keypad addresses 5-8 by using Switches 1 & 2. Refer to chart below

DIP Switch ➔	1	2
KP No: 5	OFF	OFF
KP No: 6	ON	OFF
KP No: 7	OFF	ON
KP No: 8	ON	ON

Switch 3 is unused on the PW8/16. It is used to force the armed LED to follow area A or B on other control panels.

Switch 4 MUST be OFF (if Switch 4 is ON the unit will work with earlier version 4 & 5 control panels).

## Night Monitor Panel Programming

The Night Monitor button is designed to arm or disarm Stay Mode. The Stay Mode Area is assigned to the keypad at location P76E.

The functions of the button are programmed at location P77E (eg for the button to Arm Stay Mode and be able to Disarm Stay Mode at all times you must have options 2 & 4 ON).

The "ARMED" LED function is programmed at location P71E. For example if the Night Monitor keypad is only assigned to area A and you only want the Armed LED to show the status of area A you should turn on Option 1 (Area A) at location P71E for the address assigned to the Night Monitor keypad.

If both Night Monitor buttons are pressed simultaneously, it is possible to generate a "PANIC" alarm. To enable the panic alarm function for the keypad number assigned you must have option 3 turned on at location P72E.

# Keypad Indicators

## LED Keypad

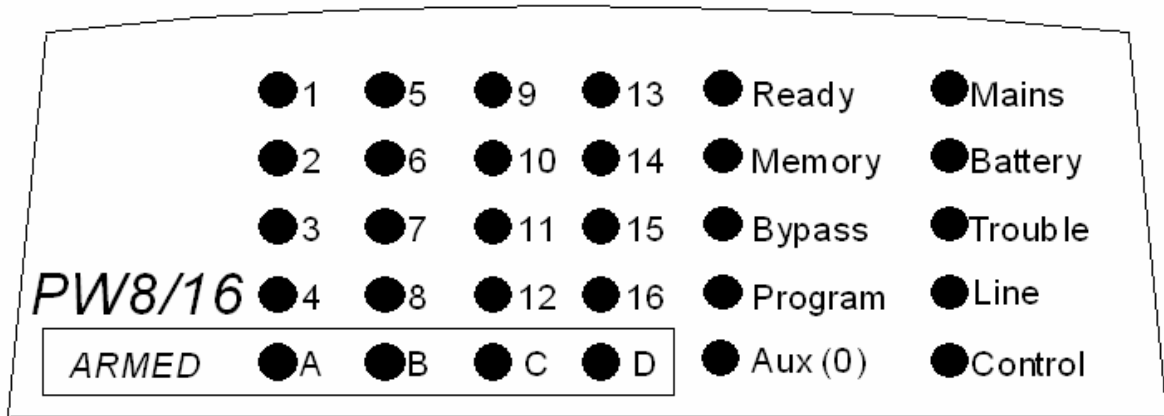

### Standard PW8/16LED Keypad Window Layout

When the Panel is displaying codes and address values in program mode it may be necessary to display the 0 digit. As there is no Zone indicator for 0 the "AUX (0)" indicator is used to show the number "0".

The Chart below gives details on the various indicators on the LED keypad and what they mean.

<b>LIGHT INDICATION</b> ↓      →	<b>OFF</b>	<b>ON STEADY</b>	<b>FLASHING</b>
READY	Zone Unsealed	All Zones Sealed	-
MEMORY	Normal	Memory Display Mode	New Memory Event
BYPASS	Bypass Off	Zone Bypass Mode Active	Zone/s Bypassed
PROGRAM	Run Mode	Client Program Mode	Installer Program Mode or Control Function Active
AUX (0)	Chime Mode ON	Chime Mode OFF	-
MAINS	-	Mains (AC) OK	Mains (AC) Fail
BATTERY	-	Battery OK	Battery Low
TROUBLE	Normal	Trouble (Tamper) Alarm Active	New Trouble (Tamper) Alarm
LINE	Telephone line is OK	Dialler is currently making a call	The Telephone line has been cut or the call was not completed
CONTROL	Control Function OFF	Control Mode On	

LIGHT INDICATION ↓      →	OFF	ON STEADY	FLASHING
ZONES 1-16	Zone Secure	Zone Unsealed (Not Ready)	Zone in Alarm
ARMED A	Partition A Disarmed	Partition A Armed	Partition A Stay Mode
ARMED B	Partition B Disarmed	Partition B Armed	Partition B Stay Mode
ARMED C	Spare		
ARMED D	Spare		

## PW8/16 LCD KEYPAD

### *CROW BIG LCD*

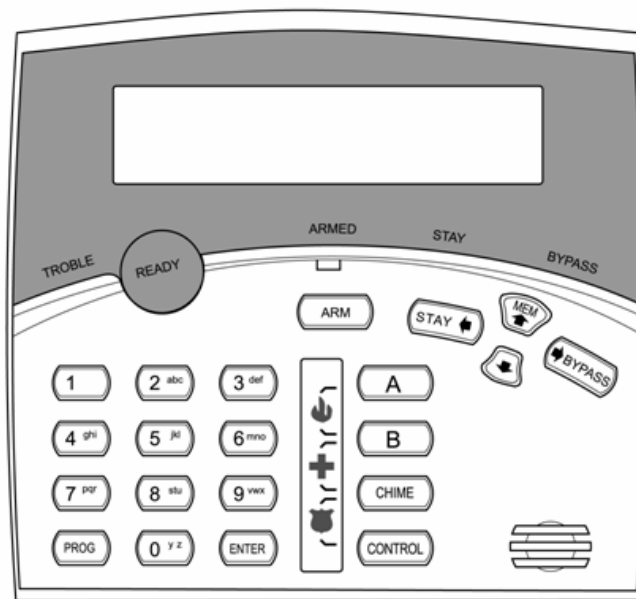

### CROW SMALL LCD

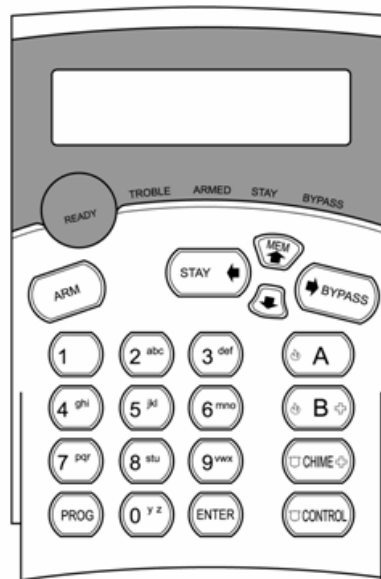

The table below gives details on the various LED indicators on the keypad and what they mean.

LIGHT\INDICATION ↓                      →	OFF	ON STEADY	FLASHING
READY	Zone Unsealed	All Zones Sealed	-
TROUBLE	Normal	Trouble (Tamper) Alarm Active	New Trouble (Tamper) Alarm
BYPASS	Bypass Off	Zone Bypass Mode Active	Zone/s Bypassed
ARMED A	Partition A or B Disarmed	Partition A or B Armed	
STAY	STAY Disarmed	STAY Armed	

## Keypad Memory Display - LED Keypad

### *Current Alarm Systems*

When viewing the memory event buffer at the keypad by pressing the “MEMORY↑” button, the first thing that will always be displayed are any Current System Alarms that are active. The Current System Alarms are indicated by the Memory/Mains & Battery LEDs being on plus a zone LED from 1-8 to indicate the system alarm/s present. If no Zone LED’s are on at this time, it means that there are no current system alarms. If a zone LED or LED’s are On then this indicates system alarms that have not yet cleared. The zone LED’s 1-8 are pre-defined as to what system alarm they will display. These system alarm indications are shown in the table below. Following the display of current system alarms the panel will then sequence through the 255 historical memory events starting at the most recent event.

CURRENT SYSTEM ALARMS			
LED # 1	Battery Low	LED # 5	Radio Pendant Battery Low
LED # 2	Mains, 12V Fuse or Output Failure	LED # 6	Supervised Detector Failure
LED # 3	Telephone Line Failure	LED # 7	SensorWatch or Delinquency Alarm
LED # 4	Radio Detector Battery Low	LED # 8	Dialler Kiss-off Failure

### *HISTORICAL MEMORY EVENTS*

Following the “Current System Alarms” the panel will display the historical memory events. The panel stores the most recent events, (up to 255), including all alarm events, all system events such as mains failure etc as well as arming by Area. The memory events are displayed via the standard keypad with the most recent event shown first and subsequent events following in descending order from newest to oldest.

The "MEMORY" light will be on while the memory display mode is active. To view events simply press the "MEMORY▲" button. The keypad will beep and the display is advanced to the next event every time the "MEMORY▲" button is pressed. When all events in memory have been displayed the keypad will exit memory mode and return to the normal idle state. To cancel the memory display just press "ENTER". If the "ENTER" button is not pressed and the display mode is not advanced to the last memory event, the keypad will automatically exit memory display mode after approximately 20 seconds. The memory light will turn off once the memory display mode has been exited. The MEMORY LED flashes when there is a new event in memory and it will stop flashing once the event has been viewed or the panel is armed.

The Chart below gives details on the various alarms and what LED indicators are used to display them.

HISTORICAL EVENT DISPLAY CHART			
EVENT	DEVICE	INDICATOR	STATUS
ACTIVATION	Zones 1-16	LED's 1-16	On Steady
BYPASS	Zones 1-16	BYPASS LED's 1-16	On Steady On Steady
DETECTOR TAMPER (SHORT CIRCUIT)	Zones 1-8	TROUBLE LED's 1-8	Flashing On Steady
DETECTOR TAMPER (OPEN CIRCUIT)	Zones 9-16	TROUBLE LED's 9-16	Flashing On Steady
CABINET TAMPER	Cabinet or Satellite Siren	TROUBLE	Flashing
WRONG CODE ALARM	Code Tamper at Keypad #	TROUBLE LED's 1-8	Flashing On Steady
CROW KEYPAD TAMPER SWITCH ACTIVATED	Keypad Tamper Alarm at Keypad #	TROUBLE LED's 1-8	On Steady On Steady

*LED KEYPAD VIEW MEMORY MODE cont*

HISTORICAL EVENT DISPLAY CHART-Continued			
EVENT	DEVICE	INDICATOR	STATUS
LOW BATTERY	Controller Battery	BATTERY	Flashing
MAINS FAILURE	Controller Mains Supply	MAINS	Flashing
12V Output FAILURE (F2 or F3)	Controller on-board Thermal fuses activated	MAINS LED 1	Flashing On Steady
OUTPUT 1 or 2 FAIL (Only applies if siren or strobe connected)	Wires to Output 1 or 2 have been cut	LED's 1 or 2 TROUBLE MAINS	On Steady On Steady On Steady

HISTORICAL EVENT DISPLAY CHART-Continued			
EVENT	DEVICE	INDICATOR	STATUS
LOW BATTERY-ZONE (Wireless detector)	Radio Zone Zone 1-16	BATTERY LED's 1-16	Flashing On Steady
LOW BATTERY-PENDANT (wireless Transmitter)	Radio Key User 21-100	BATTERY LINE CONTROL	Flashing Flashing On Steady
SENSORWATCH TIMEOUT	Zone 1-16	LED's 1-16 TROUBLE CONTROL	On Steady Flashing Flashing
SUPERVISED RADIO TIMEOUT	Zone 1-16	LED's 1-16 TROUBLE BYPASS	On Steady Flashing Flashing
RF FAILURE	No RF Activity	TROUBLE AUX (0)	Flashing Flashing
ARM DELINQUENCY ALARM	Area A or B not armed within programmed number of days	TROUBLE CONTROL	Flashing Flashing
DURESS ALARM	Duress Alarm (at Keypad #)	TROUBLE LINE LED's 1-8	Flashing Flashing On Steady
KEYPAD PANIC	Panic Alarm at Keypad	LINE LED's 1-8	Flashing Flashing
PENDANT PANIC	Radio Panic Alarm	LINE	Flashing
KEYPAD FIRE	Fire Alarm at Keypad	LINE CONTROL LED's 1-8	Flashing Flashing On Steady
KEYPAD MEDICAL	Medical Alarm at Keypad	LINE BYPASS LED's 1-8	Flashing Flashing On Steady
ARMED	Area "A" Armed	"A"	On Steady
ARMED	Area "B" Armed	"B"	On Steady
STAY MODE ON	Area "A" in Stay Mode	"A"	Flashing
STAY MODE ON	Area "B" in Stay Mode	"B"	Flashing
TELEPHONE LINE FAIL	Panel Dialler	LINE	On Steady
EXCESSIVE RE-TRIES	Panel Dialler	LINE LED 1	On Steady On Steady

HISTORICAL EVENT DISPLAY CHART-Continued			
EVENT	DEVICE	INDICATOR	STATUS
FAILURE TO GET A KISSOFF	Panel Dialler	LINE LED 2	On Steady On Steady
WALKTEST MODE	Manual Walk-test Mode	MAINS BATTERY LINE LED's 1-16	On Steady On Steady On Steady On Steady

## LCD KEYPAD

### LCD Keypad View Memory Mode

The LCD Keypad has similar operational functions to the LED keypad with one notable exception, when displaying Memory Events in "Memory Mode" it will display the events using plain text messages with the Time & date that the event occurred.

This makes the fault diagnosis much easier. On an LED keypad only the ARM indications are displayed (the disarm is removed from the display) but with the LCD keypad all events can be displayed (including when the system was disarmed and by who).

To access "Memory Mode" using the LCD keypad, press the "MEMORY↑" button.

**There are two parts to the Memory Display Mode:**

#### *CURRENT SYSTEM ALARMS*

If there are any current "SYSTEM" alarms, they will be displayed first under the heading of "CURRENT ALARMS".

There are up to 8 "system alarms" that can be displayed at this point. They are listed in the "Current System Alarms" table on page 19. The current system alarms will be displayed in plain text to describe the actual problem. If there is more than one current problem the keypad will display event alarm sequentially with the heading of "CURRENT ALARMS" on the top line and the alarm on the bottom line.

Each time the "MEMORY↑" button is pressed, the next alarm will be displayed.

If there are no system problems with the panel the display will show "NO FAULTS".

When all current system alarms have been displayed the keypad will then start to show the historical memory events.

#### *HISTORICAL MEMORY EVENTS*

Following the "Current System Alarms" the panel will display the historical memory events. The panel stores the most recent events, (up to 255), including all alarm events, all system events such as mains failure etc as well as arm/disarm by User & Area. The memory events are displayed via the LCD keypad with the most recent event shown first and subsequent events following in descending order from newest to oldest.

During the "Historical Memory Event" display mode the LCD display will show the type of event on the top line eg "Area A armed by User 1" and the actual time and date that the event occurred on the bottom line.

To view events simply press the "MEMORY↑" button. The keypad will beep and the display is advanced to the next event every time the "MEMORY↑" button is pressed.

If you wish to go back and look at an earlier event you can use the "↓" or "STAY↓" buttons to go back to an earlier event. Each time the Down arrow is pressed the memory will go back one event.

When all events in memory have been displayed the keypad will exit memory mode and return to the normal idle state. To cancel the memory display just press "ENTER".

If the "ENTER" button is not pressed and the display mode is not advanced to the last memory event, the keypad will automatically exit memory display mode after approximately 20 seconds.

When there is a new event in memory the words " NEW MEM EVENT" will be shown on the LCD display.

The " NEW MEM EVENT" display will be reset once the event has been viewed or the panel is armed.

# Keypad Address Assignment & Installation

## LED Keypad

### Installation

To separate the two keypad halves of the **Crow Slim-line LED Keypad**, unscrew the fastening screw at the bottom of the keypad.

Screw the base to the wall using the mounting holes provided. These holes will match the standard single switch plate spacing. Ensure the base is mounted right side up. The screw should be at the bottom on the Crow keypad base. When fixing the base to the wall make sure the top of the screw heads will not touch or short out the underside of the PCB when the top half of the keypad is reinstalled. Bring the cables through the centre of the base.

Connect the 4 wires to the 5 way terminal block on the rear of the keypad PCB making sure to match the cables up with the terminals as marked on the control panel's keypad port. The 5th wire is an optional "Listen-in" connection. It is connected from the "LIN" terminal of the keypad to the "Lin" terminal of the panel keypad port. With the Listen-in wire connected the user to hear the call progress during dialling at the keypad (provided the desired program options at address P175E 6E are turned on).

Once the cables have been terminated and the required address allocated (see section below) fit the front half of the keypad onto the base.

The maximum recommended cable using standard 0.2mm security cable is 50m. Cable runs exceeding this distance may require 0.5mm cable. Always use good quality cable. Some installations may require CAT5 data cable to ensure data integrity in noisy sites.

### Led Keypad Address Assignment

A total of 8 devices (keypads or proximity readers) can be connected to the panel. Each keypad must be addressed individually to avoid BUS conflicts when multiple users are operating different keypads simultaneously. By default, each keypad comes addressed as KP # 1.

Setting the LED keypad address is done in "Local Program Mode".

To enter "**Local Program Mode**" on the LED Keypad you must press and hold the <**CONTROL**> button down and within 2 seconds, press the <**BYPASS**> button.

The "PROGRAM" LED will turn on plus the current keypad address will be displayed on the zone LED's.

The default setting is address 1 so zone LED 1 will also be on.

To change the keypad address so that it is different to others connected to the panel press a number on the keypad from 1-8 relating to the address you wish to assign to the keypad, e.g. if the keypad is the second one connected to the panel and the other keypad is set to address 1, press 2 to select keypad address 2 for this keypad. The selected address will be displayed on the zone LED's (in this example LED 2 would be on).

To Exit "Local Program Mode" press the <**ENTER**> Button.

The "PROGRAM" LED will turn off and the display will return to normal with the mains & battery LED's on.

**If you do not assign a unique address to every keypad and reader connected to the keypad buss, a conflict will exist that will cause erratic operation. Each reader or keypad MUST have a different address.**

## Led Keypad Tamper Switch

Some LED keypads may have a tamper switch fitted. If the switch is fitted, the tamper monitoring is inhibited until the tamper switch is closed for the first time. After that if the switch is opened a keypad tamper alarm will be generated. If the keypad has provision for a tamper switch but the switch is not fitted, the keypad tamper alarm will be permanently inhibited because it can never be closed to start the tamper monitoring.

## LCD KEYPAD

### Installation

To separate the two keypad halves of the **Crow LCD Keypads**, unscrew the fastening screw at the bottom of the keypad.

Screw the base to the wall using the mounting holes provided. These holes will match the standard single switch plate spacing. Ensure the base is mounted right side up. The screw should be at the bottom on the Crow keypad base. When fixing the base to the wall make sure the top of the screw heads will not touch or short out the underside of the PCB when the top half of the keypad is reinstalled. Bring the cables through the centre of the base.

Connect the 4 wires to the 5 way terminal block on the rear of the keypad PCB making sure to match the cables up with the terminals as marked on the control panel's keypad port. The 5th wire is an optional "Listen-in" connection. It is connected from the "LIN" terminal of the keypad to the "Lin" terminal of the panel keypad port. With the Listen-in wire connected the user to hear the call progress during dialling at the keypad (provided the desired program options at address P175E 6E are turned on).

Once the cables have been terminated clip the front half of the keypad onto the base.

The maximum recommended cable using standard 0.2mm security cable is 50m. Cable runs exceeding this distance may require 0.5mm cable. Always use good quality cable. Some installations may require CAT5 data cable to ensure data integrity in noisy sites.

### LCD Keypad Address Assignment

A total of 8 devices (keypads or proximity readers) can be connected to the panel. Each keypad must be addressed individually to avoid BUS conflicts when multiple users are operating different keypads simultaneously. By default, each keypad comes addressed as KP # 1.

Setting the LCD keypad address is done in "Local Program Mode".

Accessing "Local Program Mode" :

To enter "**Local Program Mode**" on the Crow LCD Keypad you must press and hold the <CONTROL> button down and within 2 seconds, press the <ARM> button.

When in Local Program Mode the display will show **local mode kb 1** with the number 1 meaning the keypad address is currently 1.

To change the keypad address to be different to others connected on the panel press;

**<PROGRAM> 996 <ENTER>**

The display will now show;

### Keypad number 1

Select an unused address, eg "2" then press <ENTER> to save.

To exit "Local Program Mode" press and hold the <PROGRAM> Button for two seconds.

You can select the program location directly as shown above or there is also a menu function to navigate the various options in "Local Edit Mode" that is described in detail on page 29.

**If you do not assign a unique address to every keypad and reader connected to the keypad buss, a conflict will exist that will cause erratic operation. Each reader or keypad MUST have a different address.**

## Adjusting Backlighting and Buzzer Tone

### Adjusting the LCD Keypad Backlighting

The user can independently adjust the backlight level of the LCD display and the Keypad Buttons from off to on with 16 steps in between. The Buttons used for these special functions vary depending on the LCD keypad.

To **increase the Crow LCD backlight** level Press "CONTROL" followed within 2 seconds by "STAY". By holding down the "Control" button and repeatedly pressing the "STAY (Left Arrow)" button you can increase the LCD backlight level to the maximum.

To **reduce the Crow LCD backlight** level Press "CONTROL" followed within 2 seconds by "BYPASS". By holding down the "Control" button and repeatedly pressing the "BYPASS (Right Arrow)" button you can decrease the LCD backlight level until it is off.

To **increase the Crow Keypad Button backlight** level Press "CONTROL" followed within 2 seconds by "MEM↑". By holding down the "CONTROL" button and repeatedly pressing the "MEM↑ (Up Arrow)" button you can increase the Keypad LED backlight level to the maximum.

To **reduce the Crow Keypad Button backlight** level Press "CONTROL" followed within 2 seconds by "↓". By holding down the "CONTROL" button and repeatedly pressing the "↓ (Down Arrow)" button you can decrease the Keypad LED backlight level until it is off.

### Adjusting the Keypad Buzzer Tone

The user can adjust the frequency (tone) of the LCD keypad buzzer within a range of 16 steps. By adjusting the frequency the volume of the tone produced at the buzzer varies as well.

To **increase the frequency of the CROW LCD buzzer** Press "CONTROL" followed within 2 seconds by "A". By holding down the "CONTROL" button and repeatedly pressing the "A" button you can increase the frequency of the buzzer tone.

To **decrease the frequency of the CROW LCD buzzer** Press "CONTROL" followed within 2 seconds by "B". By holding down the "CONTROL" button and repeatedly pressing the "B" button you can decrease the frequency of the buzzer tone.

# LCD Keypad "Local Edit" Mode

## LCD Keypad

The Local Edit Program Mode allows the programming of a customised "System Name" (the name displayed during idle mode at the keypad), Customised "Zone Names" (the text that appears on the keypad when a zone is unsealed), Customised "User Names" (the User name will appear when viewing arm/disarm events in memory mode), Customised "Area Names" (the Area name will appear when viewing arm/disarm events in memory mode) and Customised "Output Names" (the Output name will appear when viewing Output On/Off events in memory mode).

## Accessing Local Edit Mode

To enter Local Edit Program Mode on a CROW LCD Keypad Press "CONTROL" followed by "ARM" and hold for 2 seconds.

### NOTE

**You must press the "Control" button first and the "Bypass" or "Arm" button must be pressed within 2 seconds of pressing the Control button. If you make a mistake press the "Enter" button then repeat the process.**

The display will now show "Local Mode kb #" where the # equals the keypad address as previously set (see "LCD keypad address assignment" on page 24 for details). There are two ways to program the keypad in "Local Edit Mode". You can enter in the program location directly from the list below or you can use the menu function to navigate through all of the program options. The menus are described on the following pages.

## Local Edit Mode Direct Program Addresses

There are a number of program addresses available to you at this point. They are;

[PROG]-[1]-[ENTER] to;	ZONE#1 TEXT (maximum 16 characters)
[PROG]-[16]-[ENTER]	ZONE#16 TEXT
[PROG]-[800]-[ENTER]	UPDATE EDITABLE TEXT TO ALL LCD KEYPADS
[PROG]-[801]-[ENTER]	RETURN ALL EDITABLE TEXT TO DEFAULT
[PROG]-[995]-[ENTER]	PANEL TYPE
[PROG]-[996]-[ENTER]	SET KEYPAD ADDRESS NUMBER FROM 1-8
[PROG]-[997]-[ENTER]	KEYPAD LANGUAGE
[PROG]-[998]-[ENTER]	AREA IDENTIFYING CHARACTER (assigning numbers or letters to Areas)
[PROG]-[999]-[ENTER]	PANEL NAME DISPLAY (maximum 16 characters)
PROG]-[1001]-[ENTER] to;	PROGRAM USER "1" NAME
PROG]-[1100]-[ENTER]	PROGRAM USER "100" NAME
[PROG]-[2001]-[ENTER]	AREA "A" IDENTIFYING NAME (maximum 16 character Area name)
[PROG]-[2002]-[ENTER]	AREA "B" IDENTIFYING NAME (maximum 16 character Area name)
PROG]-[3001]-[ENTER] to;	PROGRAM OUTPUT "1" NAME
PROG]-[3008]-[ENTER]	PROGRAM OUTPUT "8" NAME

## Keypad Tamper Switch

Some LCD keypads may have a tamper switch fitted. If the switch is fitted, the tamper monitoring is inhibited until the tamper switch is closed for the first time. After that if the switch is opened a keypad tamper alarm will be generated. If the keypad has provision for a tamper switch but the switch is not fitted, the keypad tamper alarm will be permanently inhibited because it can never be closed to start the tamper monitoring.

## LCD KEYPAD "LOCAL EDIT" MODE MENU PROGRAMMING

The LCD Keypad Main menu headings for "Local Edit" program mode are listed on this page. On entering Local Edit Mode the display will look like the example below.



To move to the next menu heading simply press the **▲** arrow. To move back to the previous heading simply press the **▼** Arrow.

**LCD "LOCAL EDIT" MENU HEADINGS**  
(Navigate with Up/Down Arrows)

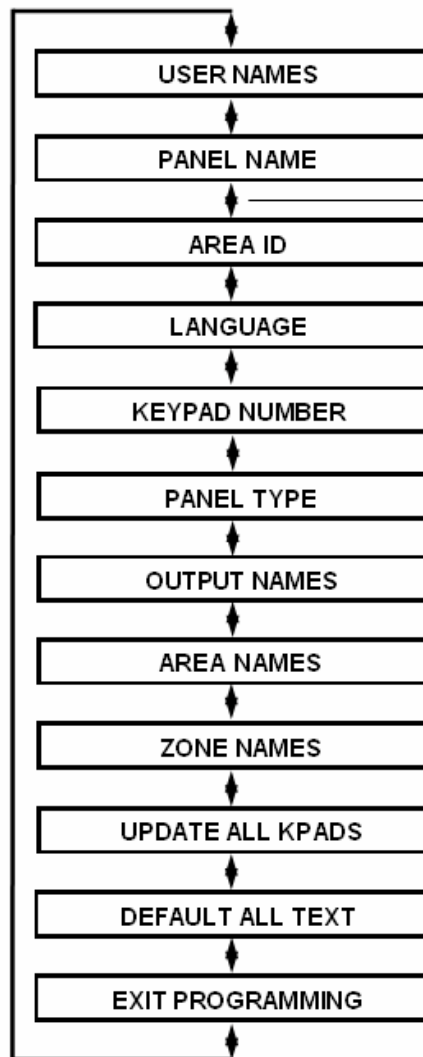

Press <▲> or <▼>  
Arrows to move between  
Menus

C

Press <PROGRAM> until  
you get here.  
Press <ENTER> to exit  
Program Mode

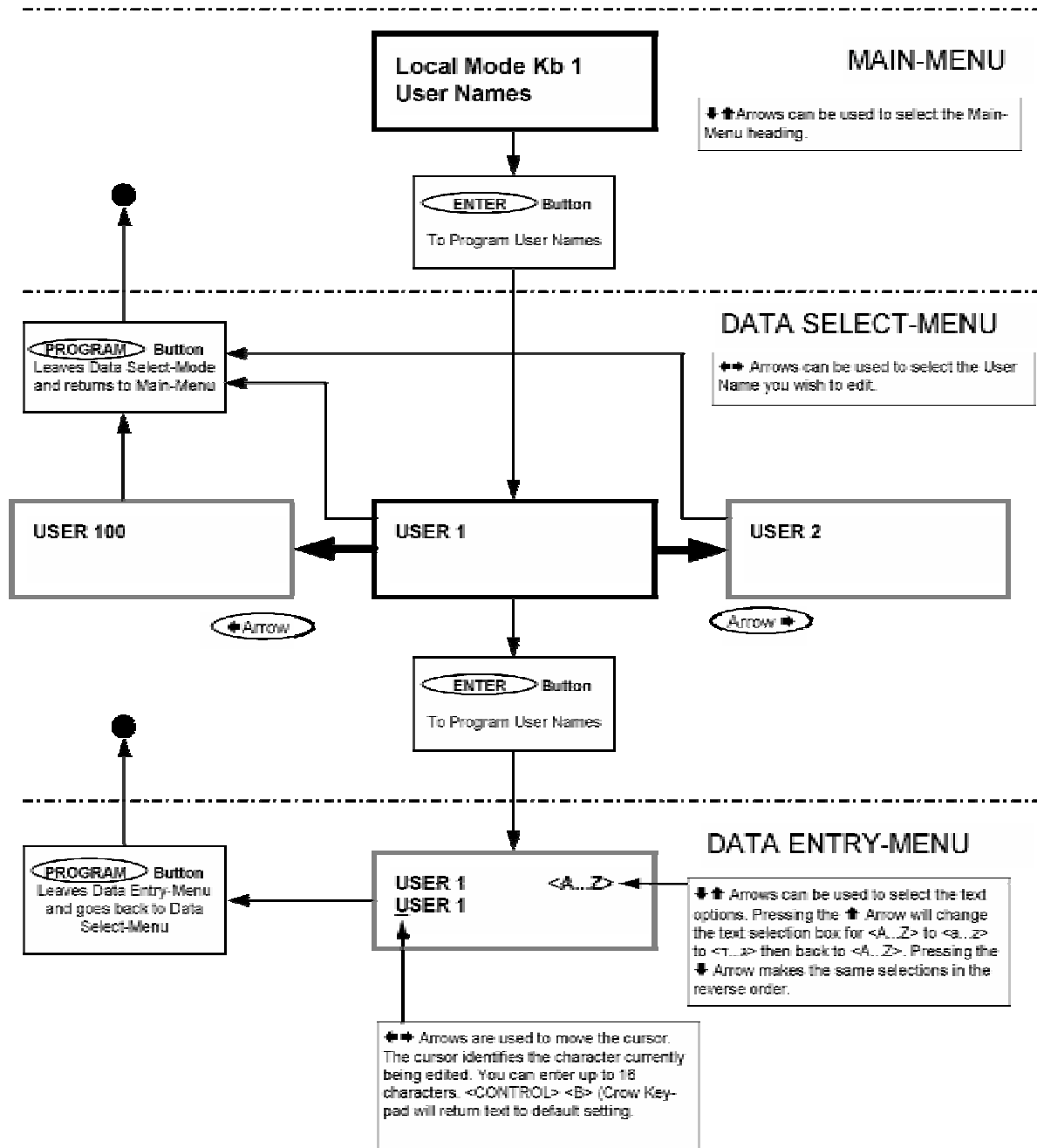

When you are at the desired main menu heading, press <ENTER> to access the data program location. See example below

### Changing the Area Single Character Identifier



When you enter in [PROG]-[998]-[ENTER] the display will look like the example above. You may edit the single character Area identifier at this address starting at Area "A" (first left-hand position). The keypad allows for up to 16 areas but the actual number of areas supported on this panel is two. The first character (in this case the "A") is the identifier used

to show the status of the first Area when armed. The second position (in this case the "B") is the identifier used to show the status of the second Area.

If you preferred to have the first area shown as Area "1" and not "A" then you can change it here using the same method as used previously. With the cursor underneath the letter "A", Press the "1" button four times until the character in the first slot shows "1".

When you are happy with the changes Press the <ENTER> button to save the changes.

## Changing the Zone Names

When in "Local Edit Program Mode" and you have entered {PROG}-[1]-[ENTER], the display will look like this;



The Cursor will be underneath the first letter to be edited (in this case the "Z").

The letters <A..Z> indicate that the letters selected by the numeric buttons (0-9) will be in capitals.

By pressing the "MEM↑ (CROW)" button once, the display will change to <a..z> indicating that the letters selected by the numeric buttons (0-9) will be lower case.

By pressing the "MEM↑ (CROW)" button again, the display will change to <7..3> indicating that Hebrew characters can be selected by the numeric buttons (0-9).

You can cycle back to another selection by pressing the "↓ (CROW)" button.

Once you have selected the desired font you can now proceed to change the text for Zone 1.

The following table shows the English Characters that can be selected by each numeric button.

The lower case options are shown in ( )

▼Button #	1st Press	2nd Press	3rd Press	4th Press
1	* (')	# (<)	= (>)	1
2	A (a)	B (b)	C (c)	2
3	D (d)	E (e)	F (f)	3
4	G (g)	H (h)	I (i)	4
5	J (j)	K (k)	L (l)	5
6	M (m)	N (n)	O (o)	6
7	P (p)	Q (q)	R (r)	7
8	S (s)	T (t)	U (u)	8
9	V (v)	W (w)	X (x)	9
0	Blank	Y (y)	Z (z)	0

There are four different selections per button. By pressing the button once, a character will appear in the display (see "1st press" column below) . Pressing the same button again will

cause the display to change to the next character in the sequence (see "2nd press" column). After you have pressed the same button four times the next press (5th) will cause the display to wrap back to the beginning.

Once you have selected the first character, Press the "BYPASS➡ (CROW)" button to move the cursor one position to the right.

Now select the second character and move the cursor to the right repeating the process until all of the text is completed (Remember that there are a maximum of 16 characters per program address).

If you make a mistake use the "STAY◀ (CROW)" button to move the cursor towards the left and make any corrections.

When you are happy with the text Press "ENTER" to save the changes. You can program the text for all zones in the same way.

## Changing the Keypad Area Name



When you enter **[PROG]-[2001]-[ENTER]** the display will look like the example above. You may edit the Area Name at this location. The area name can be up to 16 characters long. If you program in a name for the area, this name will appear when displaying events in memory display mode.

When you are happy with the changes Press the "ENTER" button to save the changes.

## Changing the Keypad Name

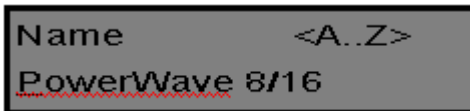

When you enter **[PROG]-[999]-[ENTER]** the display will look like the example above. You may enter any name you wish up to 16 characters in length (using the same method as described for zone names). This name is displayed at the keypad in Idle mode.

When you are happy with the changes Press "ENTER" to save.

## Changing the User Names

When in "Local Edit Program Mode" and you have entered {PROG}-[1001]-[ENTER], the display will look like this;



You can now enter in the persons name (maximum of 16 characters). When viewing events in "Memory" mode, the User name will appear to identify who the user was that Armed/Disarmed the system.

When you are happy with the changes Press <ENTER> to save.

## Changing the Output Names

When in "Local Edit Program Mode" and you have entered **[PROG]-[3001]-[ENTER]**, the display will look like this;



You can now enter an Output name (maximum of 16 characters). When viewing events in "Memory" mode, the Output name will appear to identify what function the Output is controlling.

When you are happy with the changes Press "ENTER" to save.

## Resetting Individual Text to Default or Last Saved Setting

While in "Local Edit Mode" there are two special functions that can be performed at any of the "Local Edit" Program locations. They are "Return to Default Text" or "Return to Previously Saved Text".

For Example, to Return the Zone 1 text back to Defaults;

If during the programming of Zone 1 text [PROG]-[1]-[ENTER] you wished to return back to the default text, simply Press and hold the "B" button for 2 seconds, and the text will return to the default settings.

If you wished to return to the last saved version of the text simply Press and hold the "A" button for 2 seconds and the last saved text for zone one will appear.

NOTE: If the last saved version of text for Zone 1 was in fact the default setting, then pressing "Control" then "1" or "A" will return the default text anyway.

## Resetting All Text to Default

While in "Local Edit Mode" it is possible to restore all of the customisable text fields to the factory default settings.

When you enter in [PROG]-[801]-[ENTER] display will prompt you to press [801]-[ENTER] again. Once you have pressed "801 enter", all customisable text (for example, zone names, user names, output names, etc) will be returned to the default text.

## Copying Text to Another LCD Keypad

If more than one LCD keypad is connected to the panel, it is possible to copy the edited Text from one LCD keypad to all other LCD keypads connected to the same panel.

When you enter in [PROG]-[800]-[ENTER], all of the customisable text at the keypad will be transferred to all other LCD keypads connected to the control panel.

There is also an alternative method to transfer the text. Pressing the "CHIME" button for 2 seconds while in "Local Edit Mode" will perform the transfer. The text in your keypad will be transferred to all other LCD keypads connected to the panel.

## Exiting Local Edit Program Mode

Press and hold the <PROGRAM> button for 2 seconds and the LCD keypad will leave Local Edit Mode and return to Idle Mode or; Press the <PROGRAM> button repeatedly until the display reads "Exit Programming", then press the <ENTER> button to exit program mode.

# Program Mode Access

## Accessing Program Mode

### How to Program Using Led Keypads

The programming sequence follows this pattern;

<PROGRAM> - <1,2 or 3 digit address> - <ENTER>      *(Program Address)*

**1 short beep if OK - 1 long beep if error, THEN**

<PROGRAM> - <1,2 or 3 digit sub-address> - <ENTER>      *(Sub-Address)*

**3 short beeps if OK - 1 long beep if error**

The LED's will display current value or status

Enter the new value or option

<New Value> - <ENTER>

**3 short beeps if OK - 1 long beep if error**

Throughout this manual you will see program instructions expressed as

**P 1 E 1-100 E**

Using the above example the <P> represents the **PROGRAM** key and <E> represents the **ENTER** key.

<1> refers to the address for programming User Codes and <1-100> refers to Users 1-100.

### *Access to Programming on Power Up (Installer Mode)*

When power is applied to the controller for the first time and with the panel tamper input open, the panel will inhibit tamper alarms and ready the panel to enter **INSTALLER PROGRAM MODE** (unless the Installer Lock-out at address P25E10E Option 8 has previously been enabled). At this point you can go to any keypad which is connected to the panel and press <PROGRAM> <ENTER> which will automatically put that keypad into full Program mode. The Program LED will now be Flashing (NOTE: Only one keypad can be in Program mode at any time).

### *Access to Installer Program Mode from Run Mode*

Before you can enter Installer program mode from normal operating mode, the panel must not be Armed or in Stay mode. Program mode access is inhibited if any part of the system is Armed.

Press <PROGRAM> - <Installer Code> - <ENTER>

*Program light will Flash*

Note: Default Installer Code (P25E1E) is 000000.

You are now in Installer Program Mode. Any program addresses may be viewed or changed in this mode.

### **ACCESS TO CLIENT PROGRAM MODE FROM RUN MODE**

Press <PROGRAM> - <Master User Code> - <ENTER>

*Program light On Steady*

Note: Default Master User Code is code # 1 (P1E1E) which is 1234.

You are now in Client Program Mode. Access to certain program locations is limited while in Client mode (see the options at address P5E). Each User can have different privileges based on the options assigned to the User at address P5E. If no options are set at address P5E for a user, they will not be allowed access to Client program Mode.

### *Resetting To Factory Default Settings (From Install Mode Only)*

There are two addresses that allow you to reset the panel back to the factory defaults. The first resets just User Codes, Installer Code & Telephone Numbers. The Second resets all programming back to the factory Defaults.

e.g. To reset All System defaults:

Press <PROGRAM> - <P200E10E> - <ENTER>

**3 short beeps if OK - 1 long beep if error**

After the system configuration has been reset back to defaults, all values, options & Codes will be set to the values shown in the Program Summary as defaults. These values have been chosen as the most common set-up for the majority of systems.

To reset partial defaults:

Press <PROGRAM> - <P200E9E> - <ENTER>

**3 short beeps if OK - 1 long beep if error**

The partial reset to defaults will return all User Codes, the Installer Code and Telephone Numbers back to the values shown in the Program Summary as defaults. These values have been chosen as the most common set-up for the majority of systems.

## Exiting Program Mode

### *To Exit Program Modes Using Led Keypad*

To exit either program mode when you have finished programming:

Press <PROGRAM> - <ENTER>

*Program light goes out*

The panel is now back in Run Mode, any program changes you have made will have replaced previous values and be in effect.

**Note:** During programming Tamper and 24 hour alarms are disabled which allows quiet access to the panel, detectors and external siren units, etc. On exiting program mode, all inputs are scanned and if any tamper or 24Hr alarms are present an activation will occur.

### *To Exit Program Modes Using LCD Keypad*

There are two ways to exit Program Mode with an LCD keypad. To exit either program mode when you have finished programming:

Repeatedly press the <PROGRAM> button until the display shows

"<ENTER> TO EXIT".

Now press <ENTER> to exit Program Mode.

**OR**

Press and hold the <PROGRAM> button for 2 seconds to exit program mode.

The panel is now back in Run Mode, any program changes you have made will have replaced previous values and be in effect.

**NOTE**

During programming Tamperers and 24 hour alarms are disabled which allows quiet access to the panel, detectors and external siren units, etc. On exiting program mode, all inputs are scanned and if any tamperers or 24Hr alarms are present an activation will occur..

## How to Program Using LCD Keypads

Access to Program Mode when using an LCD Keypad is exactly the same as when using an LED Keypad (see previous page for access to program mode from power-up and normal run mode).

Once in Program Mode (either Client Mode or Installer Mode), the User can still enter program addresses directly at the keypad to go straight to a particular address, as with the LED Keypad.

But the LCD Keypad also incorporates built-in menus that allow the Programmer to move through the Main-Menus using the Up/Down Arrow keys. Also when at a data entry location, the Left/Right Arrows can be used. These special Function Arrow keys are clearly marked on the keypad buttons (the position of the buttons can vary depending on the type of LCD Keypad installed).

When navigating the Menus using the Arrow keys, each button has a special function depending on where you are within the menus.





When you enter program mode the LCD Keypad display automatically defaults to "CLIENT:USER" (if in Client mode) or "INSTALLER:USER" (if in Installer mode). By using the UP or DOWN Arrows, the user can cycle through all of the available menus.

The menus are accessed in a particular order based on the most frequently used program locations. All of the Main and the Sub-Menus are shown on the following pages.

## LCD Program Menu

### *LCD Keypad Menu Programming*

The LCD Keypad enables "Manual Free" programming of the PW8/16 panel. Easy to follow plain text Menus will be displayed on the keypad to enable selection of the desired programming options.

	<ENTER> key selects the Menu you wish to work in or the option in a Sub-Menu you wish to use.
	<PROGRAM> key will step you back to the previous Menu level
	<Up> or <Down> arrow keys will allow you to cycle through the Menu options (Main & Sub Menus).
	<Left> or <Right> arrow keys can be used when in the Data Entry-Menus to cycle through the options (eg if in "USERS" Data Entry-Menu, the options would be Users 1-100, if in "ZONES" the options would be Zones 1-16, etc)

## Selecting the Main-Menu Headings ("↑ Up" Or "↓ Down" Arrow Keys)

Enter "INSTALLER" Program Mode eg <PROGRAM> - <INSTALLER CODE (000000)> - <ENTER>.

The LCD will display "INSTALLER:USERS". This is the default Main-Menu heading.

To access a desired program location you first navigate to the desired Main-Menu by using the "↑ Up" or "↓ Down" arrow keys on the keypad. Each press of "↑ Up" or "↓ Down" arrow keys will advance the display to the next Menu heading.

The Main-Menu headings are shown on the top line of the LCD display.

To access the Sub-Menu options from a Main-Menu press the <ENTER> button.

## Selecting the Sub-Menu Headings ("↑ Up" Or "↓ Down" Arrow Keys)

Having pressed the <ENTER> button at the selected Main-Menu heading the keypad will now show Sub-Menus for that heading.

The Main-Menu heading will remain on the top line of the LCD display and the Sub-Menus will appear on the bottom line.

Each press of "↑ Up" or "↓ Down" arrow keys will advance the Sub-Menus displayed on the bottom line either up or down by one location..

To access the Data Entry-Menu options from the Sub-Menu press the <ENTER> button.

## Selecting the Data Entry-Menu Headings

Having pressed the <ENTER> button at the desired Sub-Menu heading, the keypad will now be in the Data Entry-Mode.

The Main-Menu heading on the top line of the display will be replaced with the actual data entry field description, eg if you had gone from "USERS" to "CODES" then to the data entry field of codes the display will show "USER CODE 1" on the top line of the display and the code "1234" on the bottom line ("1234" being the default User 1 code). See the chart on page 39 for details.

You can now change the code, eg to change Code # 1 to 4567 press <4567> <ENTER>. The bottom line will now show the new code of "4567".

At this point you can use the "↑ Up" or "↓ Down" arrow keys to cycle through the other Sub-Menu options for User Code 1 to program all of the options for code 1, or;

You can use the "←Left" or "→Right" arrow keys to cycle through all of the User codes. This allows you to program all of the user codes from 1-100. The "→ Right" arrow key when pressed will take you up one User at a time and the "←Left" arrow key will take you down one User, eg if the display was currently showing "USER CODE 10", pressing the "← Left" arrow key will take the display to "USER CODE 9", pressing the "→ Right" arrow key will take the display to "USER CODE 11".

You can also use the "← Left" or "→ Right" arrow keys to move through all of the User codes, and while at a particular User, you can also use the "↑ Up" or "↓ Down" arrow keys to program all options for that User.

If you are at a location that has 8 programmable options, eg P4E where the User Arm/Disarm options can be set, by pressing and holding the <CONTROL> button then within 2 seconds pressing the <ENTER> button you can access the sub- text that describes what each option can do. To exit the sub-text display press <ENTER>.

## Stepping Back Through the Menus

If you are in a Menu location, eg. the "USER" Data Entry field, and you wish to step back one stage to the previous Sub-Menu, you need to press the <PROGRAM> button.

Each time the <PROGRAM> button is pressed the display will step back to the previous stage (remembering where you were before) until you get back to the Main-Menu.

For example if you were in the "KEYPADS" Main-Menu, then pressed <ENTER> to get to the "AREAS" Sub-Menu for keypads, then pressed <ENTER> again to get to the "AREAS" Data Entry-Menu for keypads, you could now press the <PROGRAM> button once and it would take you back to the "KEYPADS/AREAS" Sub-Menu. Pressing <PROGRAM> again will take you back to the "KEYPADS" Main-Menu, and pressing <PROGRAM> one more time will return you back to the default "USERS" Main-Menu.

If you get back to the "USERS" menu and press the <PROGRAM> button once more the display will go to the

program exit menu. If you press <ENTER> when at this point the panel will leave program mode. If you don't wish to leave program mode you can press the <PROGRAM> button again to return to the "USERS" menu.

The flowchart below indicates the program menu steps using the "ARROW" , "ENTER" & "PROGRAM" Buttons on the keypad.

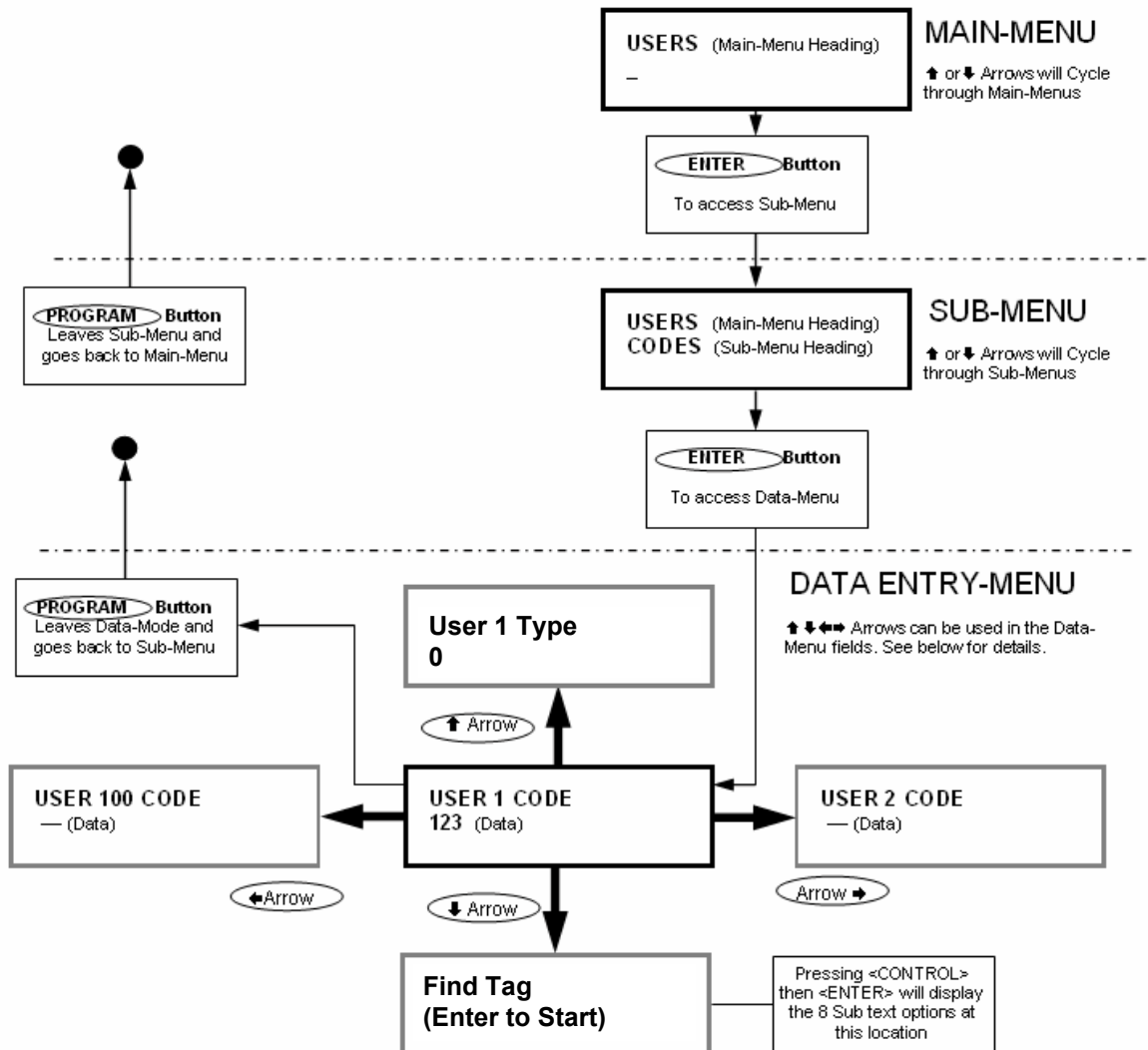

## LCD Keypad Program Menu Flowchart

There are two Menu navigating options when in the Program-Data Menus. Using the "Users" examples shown below.

1. If the "↑Up" or "↓Down" Arrows are used, the Menu will cycle through the different Sub-Menus for a particular User. See User's Data-Entry I.
2. If the "←Left" or "→Right" Arrows are used, the Menu will cycle through all of the individual Users. See User's Data-Entry II.

Users are shown as the example on this page but the same properties apply to Zones, Areas, Outputs, etc, when programming with the LCD Keypad.

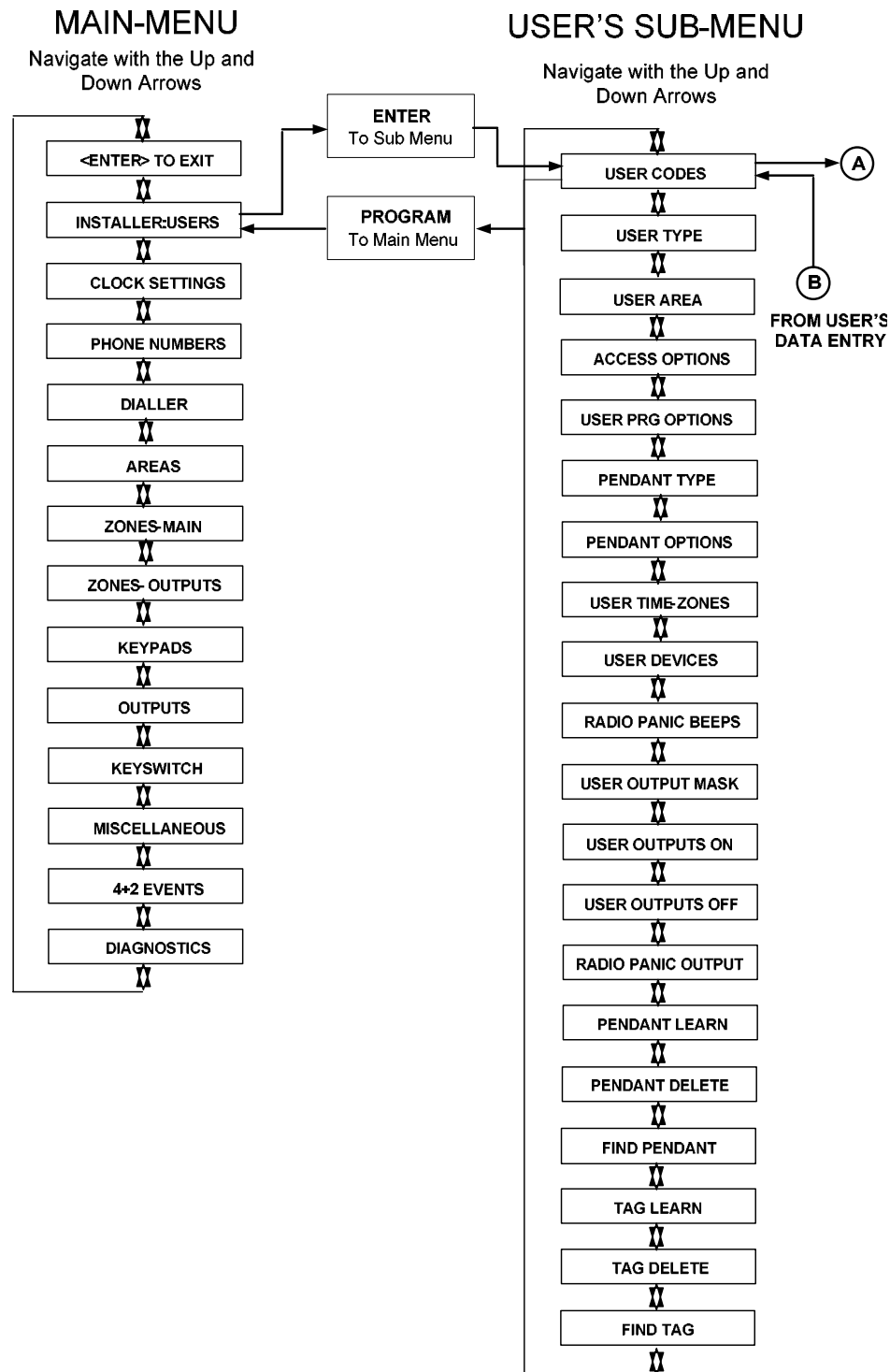

## USER'S DATA-ENTRY I

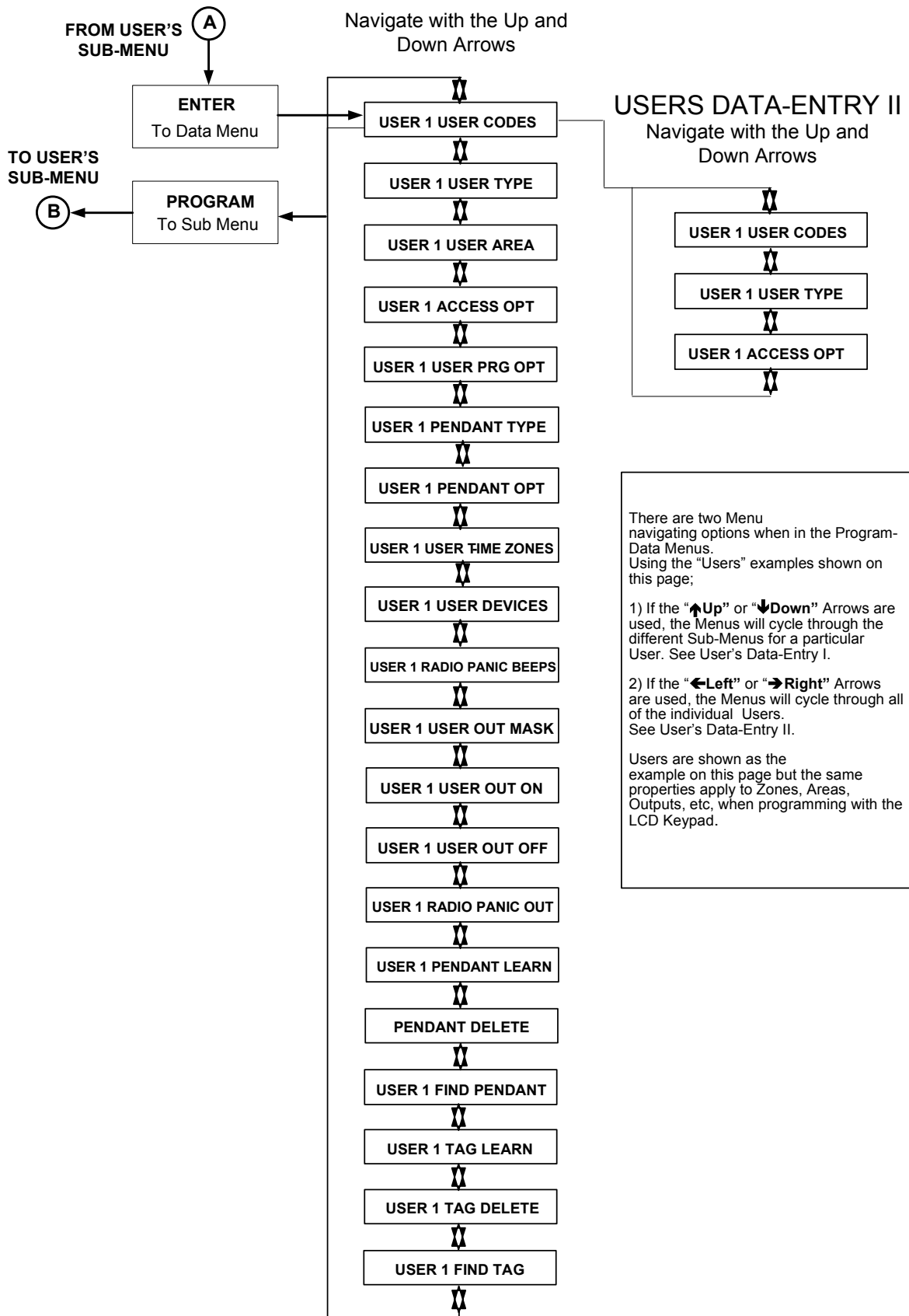

## LCD "Main" Menu Headings

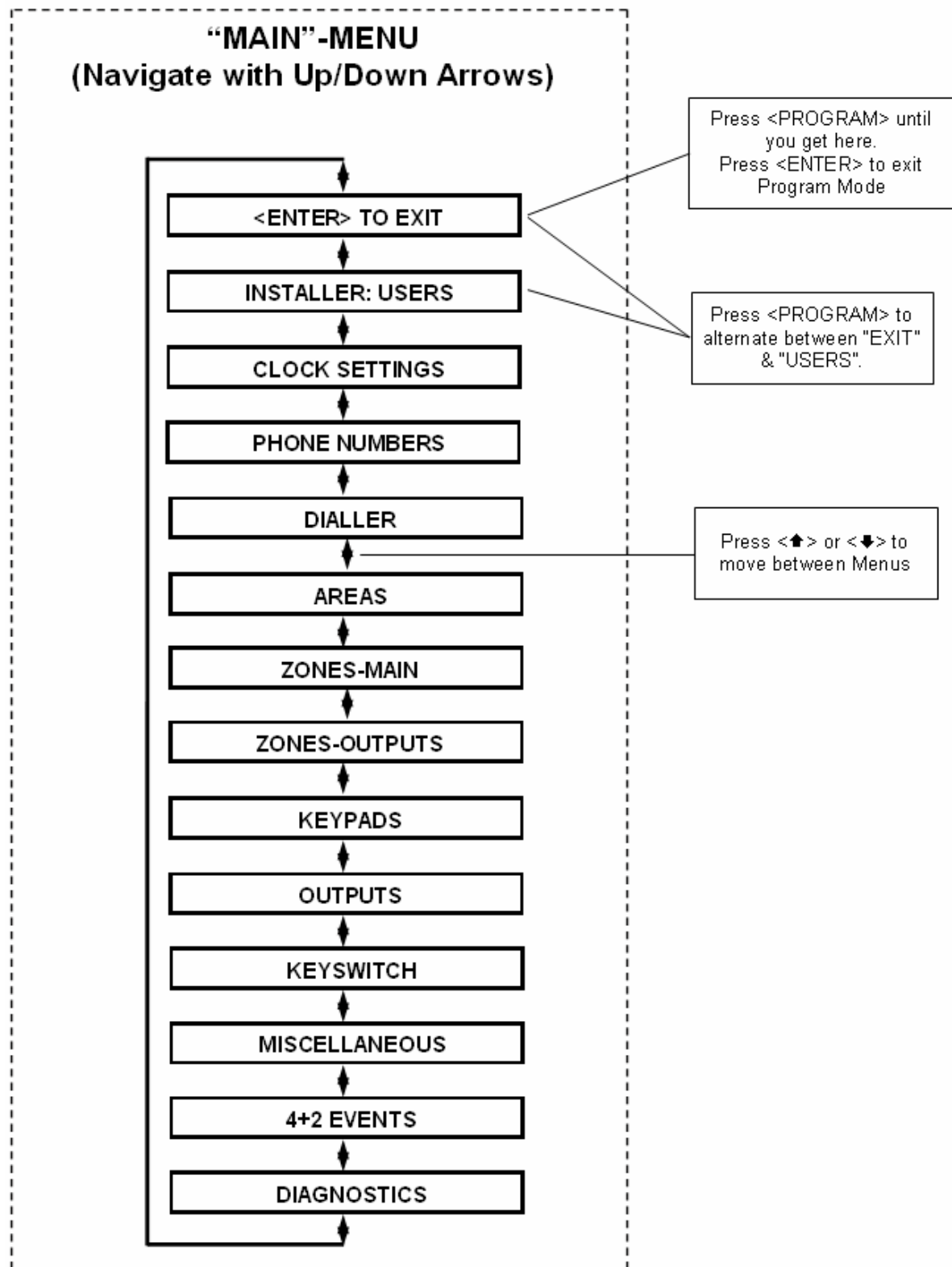

## LCD Keypad Main & Sub Menu Program Chart

### INSTALLER:USERS

USERS USER CODE P 1E	USERS USER TYPE P 2E	USERS USER AREAS P 3E	USERS USR ACCESS OPTS P 4E	USERS USR PROG OPTS P 5E	USERS PENDANT TYPE P 7E
USERS PENDANT OPTS P 8E	USERS USR TIME ZONES P 9E	USERS USR DEVICES P 10E	USERS RADIO PANIC BP P 11E	USERS USR OUTPUT MASK P 12E	USERS USR OUTPUTS ON P 13E
USERS USR OUTPUTS OFF P 14E	USERS RADIO PANIC OP P 15E	USERS PENDANT LEARN P 18E	USERS PENDANT DELETE P 19E	USERS PENDANT FIND P 20E	USERS TAG LEARN P 21E
USERS TAG DELETE P 22E	USERS TAG FIND P 23E				

### CLOCK SETTINGS

CLOCK SETTINGS TIME HH:MM P 26E	CLOCK SETTINGS WEEK DAY 1-7 P 26E	CLOCK SETTINGS DATE DDMMYY P 26E	CLOCK SETTINGS DLS STATUS P 26E	CLOCK SETTINGS DLS SUNDAY P 27E	CLOCK SETTINGS DLS MONTH P 28E
CLOCK SETTINGS DLS HOUR P 29E	CLOCK SETTINGS HOLIDAY DDMMY P 170E	CLOCK SETTINGS TZ DAYS P 171E	CLOCK SETTINGS TZ START P 172E	CLOCK SETTINGS TZ END P 173E	CLOCK SETTINGS TZ OPTIONS P 174E

DLS = daylight saving TZ = time zones

### PHONE NUMBERS

PHONE NUMBERS PHONE NUMBER P 181E	PHONE NUMBERS PHONE FORMAT P 182E	PHONE NUMBERS PHONE OPTIONS P 183E	PHONE NUMBERS PHONE RETRIEVE P 184E	PHONE NUMBERS PH A REPORTING P 186E	PHONE NUMBERS PH B REPORTING P 187E
PHONE NUMBERS PH C REPORTING P 188E	PHONE NUMBERS PH D REPORTING P 189E	PHONE NUMBERS DIVERT EVENTS P 192E	PHONE NUMBERS DIVERT OPTIONS P 193E	PHONE NUMBERS DIVERT NUM P 194E	

### DIALLER

DIALLER DIALLER A OPTION P 175E	DIALLER DIALLER B OPTION P 175E	DIALLER AUTO RING COUNT P 175E	DIALLER TEST RESYNC HHMM P 175E	DIALLER TEST PERIOD P 175E	DIALLER NPLISTEN III P 175E
DIALLER OPLLISTEN III P 175E	DIALLER PREFIX NUMBER P 175E	DIALLER PANIC CID CODE P 175E	DIALLER FIRE CID CODE P 175E	DIALLER MEDICID CODE P 175E	DIALLER OUTPUT DTMF P 175E
DIALLER MONITOR DTMF P 175E	DIALLER DTMF ACK CODE P 175E	DIALLER DTMF CALL CODE P 175E	DIALLER PANIC MESSAGE P 176E	DIALLER FIRE MESSAGE P 176E	DIALLER MEDICAL MESSAGE P 176E
DIALLER AC FAIL MESSAGE P 176E	DIALLER AC RESTORE M8G P 176E	DIALLER BATTERY LOW M8G P 176E	DIALLER BATTERY OK M8G P 176E	DIALLER TAMPER MESSAGE P 176E	DIALLER DURESS MESSAGE P 176E
DIALLER LATCH KEY M8G P 176E	DIALLER REMOTE TEST M8G P 176E				

### AREAS

AREAS <u>AREA A OPTIONS</u> P 145E	AREAS <u>AREA B OPTIONS</u> P 146E	AREAS <u>AREA ARM FOLLOW</u> P 147E	AREAS <u>AREA STAY FOLLOW</u> P 148E	AREAS <u>AREA OPEN FOLLOW</u> P 149E	AREAS <u>AREA ARM CHIRP</u> P 150E
AREAS <u>AREA STAY CHIRP</u> P 151E	AREAS <u>AREA OPEN CHIRP</u> P 152E	AREAS <u>AREA UNSTAY CHRPP</u> P 153E	AREAS <u>AREA ARM PULSE</u> P 154E	AREAS <u>AREA STAY PULSE</u> P 155E	AREAS <u>AREA OPEN PULSE</u> P 156E
AREAS <u>AREA UNSTAY PL</u> P 157E	AREAS <u>AREA ARM EXIT BP</u> P 158E	AREAS <u>AREA STAY EXIT B</u> P 159E	AREAS <u>AREA ARM EXIT TMP</u> P 160E	AREAS <u>AREA STAY EXIT TM</u> P 161E	AREAS <u>AREA ACCOUNT CD</u> P 162E
AREAS <u>AREA DTMF CODE</u> P 163E	AREAS <u>AREA MESSAGES</u> P 164E	AREAS <u>AREA EXIT-OP A</u> P 165E	AREAS <u>AREA EXIT-OP S</u> P 166E	AREAS <u>AREA DELINQ.DAYS</u> P 167E	AREAS <u>AREA ARM TZ</u> P 168E

### ZONES-MAIN

ZONES-MAIN <u>ZN AREAS</u> P 121E	ZONES-MAIN <u>ZN A OPTIONS</u> P 122E	ZONES-MAIN <u>ZN B OPTIONS</u> P 123E	ZONES-MAIN <u>ZN C OPTIONS</u> P 124E	ZONES-MAIN <u>ZN BOL MODE</u> P 125E	ZONES-MAIN <u>ZN RESPONSE</u> P 126E
ZONES-MAIN <u>ZN RADIO TYPE</u> P 127E	ZONES-MAIN <u>ZN ARM BEEPS</u> P 134E	ZONES-MAIN <u>ZN STAY BEEP S</u> P 135E	ZONES-MAIN <u>ZN 24HR BEEP S</u> P 136E	ZONES-MAIN <u>ZN CHIME BEEPS</u> P 137E	ZONES-MAIN <u>ZN TAMP BEEPS</u> P 139E
ZONES-MAIN <u>ZN SUPV BEEPS</u> P 140E	ZONES-MAIN <u>ZN ACTV BP</u> P 141E	ZONES-MAIN <u>ZN ARM ENT BP</u> P 142E	ZONES-MAIN <u>ZN STAY ENT BP</u> P 143E	ZONES-MAIN <u>ZN ARM ENT TM</u> P 144E	ZONES-MAIN <u>ZN STAY ENT TM</u> P 145E
ZONES-MAIN <u>ZN LOCKOUT TM</u> P 146E	ZONES-MAIN <u>ZN AL CID CODE</u> P 157E	ZONES-MAIN <u>ZN NEAR AL CID</u> P 158E	ZONES-MAIN <u>ZN CONF AL CID</u> P 159E	ZONES-MAIN <u>ZN ALM VOICE MSG</u> P 160E	ZONES-MAIN <u>ZN ACT TMR</u> P 163E
ZONES-MAIN <u>ZN LEARN RADIO</u> P 164E	ZONES-MAIN <u>ZN DEL RADIO</u> P 165E	ZONES-MAIN <u>FN D RADIO</u> P 166E			

### ZONES-OUTPUTS

ZONES-OUTPUTS <u>ZN ARM OUTS</u> P 128E	ZONES-OUTPUTS <u>ZN STAY OUTS</u> P 129E	ZONES-OUTPUTS <u>ZN 24HR OUTS</u> P 130E	ZONES-OUTPUTS <u>ZN CHIME OUTS</u> P 131E	ZONES-OUTPUTS <u>ZN TAMP OUTS</u> P 132E	ZONES-OUTPUTS <u>ZN ENTRY OR AWAY</u> P 161E
ZONES-OUTPUTS <u>ZN ENTRY OR STAY</u> P 162E					

### KEYPADS

KEYPADS <u>KP AREAS</u> P 71E	KEYPADS <u>KP KEYS</u> P 72E	KEYPADS <u>KP BEEPS</u> P 73E	KEYPADS <u>KP ARM AREAS</u> P 74E	KEYPADS <u>KP ARM ACCESS</u> P 75E	KEYPADS <u>KP STAY AREAS</u> P 76E
KEYPADS <u>KP STAY ACCESS</u> P 77E	KEYPADS <u>KP A KEY AREAS</u> P 78E	KEYPADS <u>KP A KEY OPTNS</u> P 79E	KEYPADS <u>KP B KEY AREAS</u> P 80E	KEYPADS <u>KP B KEY OPTNS</u> P 81E	KEYPADS <u>KP USR OP MSG</u> P 82E
KEYPADS <u>KP CONTRL MSG</u> P 83E	KEYPADS <u>KP PANIC OUTS</u> P 84E	KEYPADS <u>KP FIRE OUTS</u> P 85E	KEYPADS <u>KP MEDIC OUTS</u> P 86E	KEYPADS <u>KP DURESS OUTS</u> P 87E	KEYPADS <u>KP TAMP OUTS</u> P 88E
KEYPADS <u>KP ERROR OUTS</u> P 89E	KEYPADS <u>KP PANIC BP</u> P 90E	KEYPADS <u>KP FIRE BP</u> P 91E	KEYPADS <u>KP MEDIC BP</u> P 92E	KEYPADS <u>KP TAMP BP</u> P 93E	KEYPADS <u>KP CHIME TMR</u> P 94E
KEYPADS <u>PROX LED FOLLOW S</u> P 98E	KEYPADS <u>READER LEARN</u> P 99E				

**OUTPUTS**

OUTPUTS OP A OPTIONS P34E	OUTPUTS OP B OPTIONS P35E	OUTPUTS OP C OPTIONS P36E	OUTPUTS OP D OPTIONS P37E	OUTPUTS OP DELAY TIME P38E	OUTPUTS OP FLASH TIME P39E
OUTPUTS OP RESET TIME P40E	OUTPUTS OP CHIME TIME P41E	OUTPUTS OP MESSAGES P42E	OUTPUTS UN-MAPOP P43E	OUTPUTS TIMEZONES TO OP P44E	

**KEYSWITCH**

KEYSWITCH KEYSW AREAS P111E	KEYSWITCH KEYSW ACCESS P112E
--------------------------------	---------------------------------

**MISCELLANEOUS**

MISCELLANEOUS INSTALLER CODE P25E	MISCELLANEOUS DURESS DIGIT P25E	MISCELLANEOUS REPORTING DELAY P25E	MISCELLANEOUS SUPERVISED TIMER P25E	MISCELLANEOUS TWO TRIGGER TIME P25E	MISCELLANEOUS AC FAIL DELAY P25E
MISCELLANEOUS RADIO RESET TIME P25E	MISCELLANEOUS SECURITY CODE P25E	MISCELLANEOUS TEMP/OP DISABLE P25E	MISCELLANEOUS MISC OPTIONS P25E	MISCELLANEOUS INSTALLER OPTS P25E	

**4+2 EVENT CODES**

4+2 EVENT CODES USR ARM 4+2 P16E	4+2 EVENT CODES USR OPEN 4+2 P17E	4+2 EVENT CODES ZIN ALARM 4+2 P147E	4+2 EVENT CODES ZIN RESTORE 4+2 P148E	4+2 EVENT CODES ZIN NEAR ALM 4+2P 149E	4+2 EVENT CODES ZIN NEAR RST 4+2 P150E
4+2 EVENT CODES ZIN CONF ALM 4+2P 151E	4+2 EVENT CODES ZIN CONF RST 4+2 P152E	4+2 EVENT CODES ZIN BYPASS 4+2 P155E	4+2 EVENT CODES ZIN UNBYP 4+2 P156E	4+2 EVENT CODES AC FAIL 4+2 P195E	4+2 EVENT CODES AC OK 4+2 P195E
4+2 EVENT CODES BATTERY LOW 4+2P 195E	4+2 EVENT CODES BATTERY OK 4+2 P195E	4+2 EVENT CODES TAMPER 4+2 P195E	4+2 EVENT CODES TAMPER RESET 4+2P 195E	4+2 EVENT CODES REMOTE ARM 4+2 P195E	4+2 EVENT CODES REMOTE OPEN 4+2P 195E
4+2 EVENT CODES DURESS 4+2 P195E	4+2 EVENT CODES TEST CALL 4+2 P195E	4+2 EVENT CODES ARM BUTTON 4+2 P195E	4+2 EVENT CODES STAY MODE 4+2 P195E	4+2 EVENT CODES ARM/STAY OFF 4+2P 195E	4+2 EVENT CODES KS ARM 4+2 P195E
4+2 EVENT CODES KS OPEN 4+2 P195E	4+2 EVENT CODES TZ ARM FAIL 4+2 P195E	4+2 EVENT CODES KP PANIC 4+2 P195E	4+2 EVENT CODES KP PANIC OK 4+2 P195E	4+2 EVENT CODES KP FIRE 4+2 P195E	4+2 EVENT CODES KP FIRE OK 4+2 P195E
4+2 EVENT CODES KP MEDIA 4+2 P195E	4+2 EVENT CODES KP MEDIA OK 4+2 P195E				

**DIAGNOSTICS**

DIAGNOSTICS PANEL VERSION P200E	DIAGNOSTICS THIS KEYPAD P200E	DIAGNOSTICS AREAS FOR KEYPAD P200E	DIAGNOSTICS ACTIVE TIMEZONES P200E	DIAGNOSTICS BATTERY VOLTAGE P200E	DIAGNOSTICS WALK TEST MODE P200E
DIAGNOSTICS WRITE TO EEPROM P200E	DIAGNOSTICS READ FROM EEPROM P200E	DIAGNOSTICS CLEAR USER/PHONE P200E	DIAGNOSTICS CLEAR ALL P200E	DIAGNOSTICS CLEAR MEM BUFFER P200E	DIAGNOSTICS START CALLBACK P200E

# Special Keypad Functions

## Arming or Disarming Two Areas at a Keypad

If the panel is configured for two Areas "A&B", and the option "ARM" button required before code is turned on (P45E Option 1), there are a number of possible arming options.

If a user code is only assigned to one area and they press <ARM> <CODE> <ENTER> at the keypad, only the Area assigned to their code will Arm.

If a user code is assigned to both areas but the keypad being used is only assigned to one area, pressing <ARM> <CODE> <ENTER> will only arm the area assigned to the keypad.

If a user code is assigned to both areas and the keypad being used is also assigned to both areas, pressing <ARM> <CODE> <ENTER> will put the keypad into a "Ready to Arm" state. On the LCD keypad the display will show "Area/s to Arm" "A B", and on the LED keypad LED's 1 & 2 (LED 1 = Area A & LED 2 = Area B) will turn on.

If you press the <ENTER> button now, both areas A&B will arm. If before pressing the enter button you wish to deselect one of the Areas eg if you only want to arm area B press the number "1" and Area "A" will disappear on the LCD keypad display or the number "1" will turn off on the LED keypad indicating that only area B will arm when the enter button is pressed.

The number "1" will toggle area A on/off and the number "2" will toggle area B on/off.

If you don't do anything the panel will proceed with arming both areas after 10 seconds time has elapsed.

On disarming, after entering <CODE> <ENTER> the display on the LCD keypad will show "Area/s to Disarm" "A B", and on the LED keypad LED's 1 & 2. You can press the <ENTER> button at this point to disarm both areas, select which area you wish to disarm by using the numbers 1 & 2 on the keypad, or if you don't do anything the panel will proceed with disarming both areas after 10 seconds time has elapsed.

## LCD Quick View Mode

If any zones are unsealed when disarmed the LCD keypad will scroll through each unsealed zone displaying the 16 character name for each zone. If a number of zones are unsealed simultaneously it can take sometime for the display to show all of the unsealed zones.

By pressing the <ENTER> button when zones are unsealed the keypad will enter the "Quick-view" mode. When in "Quick-view" mode, each unsealed zone is displayed as a single two digit number eg "01 05 10". Up to 5 unsealed zones maybe displayed at one time. If more than 5 zones are unsealed at the time the display will scroll to the next bank of 5 zones so the user can see quickly which zones are unsealed. To exit "Quick-view" mode you simply press the <ENTER> button again or the keypad will time out automatically in approximately 30 seconds.

## Toggle Chime Mode On/Off

On the Crow LCD Keypad there is a "CHIME" button. Pressing and holding that button for two seconds will toggle Chime Mode from On-Off or Off-On.

## Send Manual Test Call

If the panel is configured for Contact ID reporting and test calls are programmed to report, you can force a manual test call by pressing and holding <CONTROL> followed within 2 seconds by <0>. This will cause a manual test call to be sent to the monitoring company. You can also dial into the panel from a remote site and using the telephone cause a manual test call remotely. See P175E15E and P176E11E for details.

## Manually Answer an Incoming Call

If the panel is not configured to answer in-coming calls, the user can force it to answer the call by pressing and holding <CONTROL> followed within 2 seconds by <9>. This will make the panel answer the call immediately. For this function to work the phone line must be ringing at the time and there must have been at least two rings before pressing the buttons.

# Programming Users

## User Codes

P1E 1-100E (NOTE: Users 21-100 can be Radio Users)

### Adding or changing a User Code

Up to 100 codes can be programmed into the panel. The user codes are located in address P1E 1-100E.

By default, Code 1 has Master Code permissions and must be used to enter Client program mode.

Codes 1-100 may be varied in length from 1 to 6 digits (unless option 8 at P25E11E is on then the codes must be between 4-6 digits long).

To program a User Code you must first be in client or installer program mode, then select the address P1E followed by the User Number you wish to program eg 1-100E (If there is already a code programmed at this address, it will be displayed back to you) Now enter the code then press the <ENTER> key.

eg. P1E2E 2580 E

3 beeps - program light on solid or flashing

In this example we have programmed Code 2 to be 2580.

eg. P1E5E 9876 E

3 beeps - program light on solid or flashing

In this example we have programmed code 5 to be 9876

To replace a code simply enter the new code in the same address as the old code. This will overwrite the previous code but maintain the user permissions as mapped to that user number.

NOTE: When displaying User Codes on an LED keypad, digits 1-9 use the zone indicators 1-9. The digit 0 is indicated by the "AUX" light.

### Removing a User Code

To remove or delete a code simply press the <BYPASS> button after entering the code address when using an LED keypad, or press and hold the <CONTROL> button then within 2 seconds press the <0> button if using an LCD keypad.

e.g. LED Keypad press P1E3E <BYPASS> E

3 beeps - Program light on solid or flashing

User Code # 3 Erased

e.g. LCD Keypad press P1E3E <CONTROL> then <0>

3 beeps

User Code # 3 Erased

## User Code Type

**USER CODE TYPE** - P2E 1-100E (NOTE: only Users 21-100 can be Radio Users)

Option 0 - Keypad Code User {PIN}

Option 1 - Radio user (User 21-100 only)

Option 2 - Access Tag/Card User

Option 3 - Both Code and Access Tag/Card User {Tag + PIN}

Option 4 - Either Code or Access Tag/Card User {Tag or PIN}

Option 0 **Keypad Code User {PIN}** - All 100 Users can be 1-6 digit code Users if required. Codes can be used to Arm/Disarm all or part of the alarm or they can be used to operate outputs for access control purposes. Users can be assigned to keypads and so can outputs so that a User assigned to multiple outputs (which can in turn be linked to doors) can operate only the door assigned to the keypad they are using.

Option 1 **Radio User** - Users 21-100 can be Radio keys (Pendant) if required. Radio keys can be used to Arm/Disarm all or part of the alarm or they can operate outputs directly. Unlike user codes, a radio key cannot be assigned to a keypad so if a radio key is assigned to more than one output and the radio key is operated, all of the outputs assigned to the radio key will turn on.

Option 2 **Access Tag/Card User** - Users 1-100 can be Access Tags or Cards if required. Access Tag or Card operation requires that the optional Proximity Reader is connected to the panel. The Proximity Readers can be assigned to any one of the 8 possible keypad addresses. Access tag or Card Users can be used to Arm/Disarm all or part of the alarm or they can be used to operate outputs for access control purposes. Access Tags or Cards can be assigned to a keypad address and so can outputs so that an Access User assigned to multiple outputs (which can in turn be linked to doors) can operate only the door assigned to the keypad address they are using.

Option 3 **Both Code and Access Tag/Card User {Tag + PIN}** - Up to 100 code Users and up to 100 tag or card Users can be stored in the panel. If the Proximity Reader with the full keypad is installed on the panel, it is possible to arm/disarm the alarm or gain access through a door by presenting the tag/card at the reader then entering in the user code {PIN Number}. It MUST be in that order ie Tag then PIN. This option provides a more secure means of arming or disarming the alarm, or gaining access through a door, because it requires both the access tag/card plus the PIN number.

Option 4 **Either Code or Access Tag/Card User {Tag or PIN}** - Up to 100 code Users and up to 100 tag or card Users can be stored in the panel. If the Proximity Reader with the full keypad is installed on the panel, it is possible to arm/disarm the alarm or gain access through a door by entering in the user code at the reader or presenting the tag/card at the reader. This option gives two methods of controlling the alarm.

## User Areas

**USER AREAS** - P3E 1-100E

Option 1 - Assigned to Area A

Option 2 - Assigned to Area B

Option 1 **Assigned to Area A** - If a User has option 1 on, they can Arm/Disarm all zones assigned to Area A

Option 2 **Assigned to Area B** - If a User has option 2 on, they can Arm/Disarm all zones assigned to Area B

## User Access Options

### USER ACCESS OPTIONS - P4E 1-100E

Option 1 - User can Arm Area

Option 2 - User can Arm Stay Area

Option 3 - User can Disarm Area

Option 4 - User can Disarm Stay Area

Option 5 - User is a Security Guard User

Option 6 - User will Arm Latchkey Mode

Option 7 - User can set Call Divert Mode on Arm/Disarm

Option 8 - Spare

Option 1 **User can Arm Area** - If a User has option 1 on, they can Arm all Areas assigned at location P3E.

Option 2 **User can Arm Stay Area** - If a User has option 2 on, they can Arm Stay Mode for all Areas assigned at location P3E.

Option 3 **User can Disarm Area** - If a User has option 3 on, they can Disarm all Areas assigned at location P3E.

Option 4 **User can Disarm Stay Area** - If a User has option 4 on, they can Disarm Stay Mode for all Areas assigned at location P3E.

Option 5 **User is a Security Guard User** - If a User has option 5 on, they can Arm all Areas assigned at location P3E, but they may only Disarm if the panel is currently Armed and in the alarm state.

Option 6 **User will Arm Latchkey Mode** - If this option is on, the User will Arm the alarm in Latchkey Mode. Latchkey Mode can also be armed by using the <ARM>, <STAY>, <A> or <B>, (see P75E, P77E, P79E & P81E option 6) or the key-switch (see P112E option 6). If a User with this option on Disarms the alarm no Disarm report will be sent via the dialler. If Latchkey Mode is Armed and a user with this option off Disarms the alarm a disarm report will be sent to alert parents when their children have returned home. Reporting of Latchkey Disarm is enabled at location (P189E option 1). If a Voice report is desired the message is assigned at P176E10E. Normally you would select a telephone number/s set for domestic or voice reporting to report the Latchkey disarm signal.

Option 7 **User can set Call Divert Mode on Arm/Disarm** - If a User has option 7 on, they can initiate the Call Divert Number/s to be dialled on Arm/Disarm. This allows automatic call diversion when the alarm is Armed and taking the diversion off when Disarmed. Call divert must also be programmed (P192-194E).

## User Code Privileges - user program options

### **USER CODE PRIVILEGES - P5E 1-100E (see chart on page 112 for the exact program locations)**

Option 1 - User can Change Their Code

Option 2 - User can Change All Codes

Option 3 - User can Allow Access to Installer Mode/Edit All Codes

Option 4 - User can Change Telephone Numbers

Option 5 - User can Change Clock Settings

Option 6 - User can Change DTMF Codes

Option 7 - User can Learn New Radio Devices

Option 8 - User can Force a Download to the Call-back Number

Option 1 **User can Change Their Code** - If a User has option 1 on, they can access Client Program Mode and change their code number.

Option 2 **User can Change All Codes** - If a User has option 2 on, they can access Client Program Mode and change All User code numbers.

Option 3 **User can Allow access to Installer Mode/Edit All Codes** - If a User has option 3 on, they can access Client program Mode. From there an Installer with the correct Installer Code can access Installer Program Mode. The User with this option can also edit all User Codes and associated parameters as shown in the chart on page 135.

Option 4 **User can Change Telephone Numbers** - If a User has option 4 on, they can access Client Program Mode and change the telephone and call divert numbers.

Option 5 **User can Change Clock Settings** - If a User has option 5 on, they can access Client Program Mode and change the Time & date settings as well as daylight saving start and finish times.

Option 6 **User can Change DTMF Codes** - If a User has option 6 on, they can access Client Program Mode and change the DTMF Codes. A DTMF Code can be used to remotely Arm/Disarm an Area, turn Output/s On/Off or Acknowledge a Voice/Domestic alarm.

Option 7 **User can Learn New Radio Devices** - If a User has option 7 on, they can access Client Program Mode and Learn a new Radio Key or Wireless Zone Device. They can also remove radio devices or find what location number a device is stored at.

Option 8 **User can Force a Download to the Call-back Number** - If a User has option 8 on, they can access Client Program Mode and force a PC connection to a pre-defined call-back number. They can either enter in P200E12E or if using an LCD keypad go to the "Diagnostics" Menu and select "Start Callback".

## Radio User Type - pendant type

### **RADIO USER TYPE - P7E 21-100E (NOTE: only Users 21-100 can be Radio Users)**

Option 0 - Generic (General Pendant Type)

Option 1 - Crow Fremlink Pendant

Option 21 - Ness Pendant

Option 0 **Generic Type** - If a Radio Pendant has no special functions and does not send a battery low signal it is a Generic type 0.

Option 1 **Crow Fremlink Type** - If a Crow Fremlink Radio Pendant is being used set the type to 1. When the pendant detects a battery low it will send a signal to the panel.

Option 21 **Ness Type** - If a Ness Radio Pendant is being used set the type to 21. When the pendant detects a battery low it will send a signal to the panel.

## Radio User Privileges – pendant options

### RADIO USER PRIVILEGES - P8E 21-100E (NOTE: only Users 21-100 can be Radio Users)

Option 1 - Pendant can Disarm at All Times

Option 2 - Pendant will cause an Immediate Panic Alarm

Option 3 - Pendant will cause a Delayed Panic Alarm (1.5 sec)

Option 4 - Spare

Option 5 - Spare

Option 6 - Spare

Option 7 - Spare

Option 8 - Spare

Option 1 **Pendant can Disarm at All Times** - If a Radio Pendant has option 1 on, they can Disarm the alarm at any time. If this option is off, the pendant cannot disarm if the panel is in alarm state.

Option 2 **Pendant will cause an Immediate Panic Alarm** - If a Radio Pendant has option 2 on, a Panic Alarm will be generated immediately the button is pressed.

Option 3 **Pendant will cause a Delayed Panic Alarm** - If a Radio Pendant has option 3 on, a Panic Alarm will be generated if the button is pressed for longer than 1.5 seconds. If the button is released before the time expires, no Panic Alarm will be generated.

## User Time Zone Assignments

### Time Zone Assigned To a User - P9e 1-100e

Option 1 - User Controlled by Time Zone # 1

Option 2 - User Controlled by Time Zone # 2

Option 3 - User Controlled by Time Zone # 3

Option 4 - User Controlled by Time Zone # 4

Option 5 - User Controlled by Time Zone # 5

Option 6 - User Controlled by Time Zone # 6

Option 7 - User Controlled by Time Zone # 7

Option 8 - User Controlled by Time Zone # 8

There are up to 8 Time Zones that can be programmed into the panel. A Time Zone consists of a Start and Stop time plus the Days of the Week that the Time Zone is active. By selecting Options 1-8 (function turned on) to a particular User, that user will only operate if the Time Zone assigned is active.

For example, if Time Zone #1 had a start time of 0800 and a stop time of 1700 and active days of 2-6 (Monday-Friday), a User with Time Zone 1 assigned can only be used between the hours of 0800-1700 from Monday to Friday. Outside these hours the User Code will not operate.

More than one Time Zone can be assigned to a User. Using the above example for TZ#1 and now assuming Time Zone #2 is set to 0900-1200 on day 7 (Saturday), by assigning both TZ1 & 2 to a User will now mean their code is active during weekdays from 0800-1700 plus they are also able to use their code on Saturdays between the hours of 0900-1200.

If the time-zone has just been programmed and should currently be active you will have to wait until the next minute expires before the panel will update the time-zone status. You can see if the time-zone is active at location P200E4E.

## User to Keypad Assignment – user devices

### User to Keypad Assignment - P10E 1-100E

- Option 1 - User will work at Keypad # 1
- Option 2 - User will work at Keypad # 2
- Option 3 - User will work at Keypad # 3
- Option 4 - User will work at Keypad # 4
- Option 5 - User will work at Keypad # 5
- Option 6 - User will work at Keypad # 6
- Option 7 - User will work at Keypad # 7
- Option 8 - User will work at Keypad # 8

Any user can be assigned to only operate at certain Keypads. This option controls whether a code or access tag User can Arm/Disarm from certain keypads. This option does not restrict users from operating outputs from a particular keypad (this is done at locations P82E & P83E).

## Radio Pendant Panic Beeps to Keypad

### Radio Pendant Panic Beeps to Keypad

P11E 21-100E (NOTE: only Users 21-100 can be Radio Users)

- Option 1 - A Pendant Panic Alarm will Beep at Keypad # 1
- Option 2 - A Pendant Panic Alarm will Beep at Keypad # 2
- Option 3 - A Pendant Panic Alarm will Beep at Keypad # 3
- Option 4 - A Pendant Panic Alarm will Beep at Keypad # 4
- Option 5 - A Pendant Panic Alarm will Beep at Keypad # 5
- Option 6 - A Pendant Panic Alarm will Beep at Keypad # 6
- Option 7 - A Pendant Panic Alarm will Beep at Keypad # 7
- Option 8 - A Pendant Panic Alarm will Beep at Keypad # 8

If a Radio Pendant is programmed to create a Panic Alarm (see P8E), when the Panic Alarm is activated it can be silent or it can sound the keypad buzzer. Each keypad can be silent during a Pendant Panic Alarm (option turned off) or can give an audible indication of the Alarm (option turned on).

## User to Output Mask

User to Output Mask - P12e 1-100e

- Option 1 - User is Mapped to Output # 1
- Option 2 - User is Mapped to Output # 2
- Option 3 - User is Mapped to Output # 3
- Option 4 - User is Mapped to Output # 4
- Option 5 - User is Mapped to Output # 5
- Option 6 - User is Mapped to Output # 6
- Option 7 - User is Mapped to Output # 7
- Option 8 - User is Mapped to Output # 8

Any user can be allowed to only operate certain Outputs. This Function is mainly used for access control purposes. If an Output is being used to open a door but a User does not have access through that door, by not allowing the User to operate that Output access through the door can be denied.

## User Can Turn an Output ON and OFF

### User Can Turn an Output ON

#### User Can Turn an Output On - P13e 1-100e

- Option 1 - User can turn ON Output # 1
- Option 2 - User can turn ON Output # 2
- Option 3 - User can turn ON Output # 3
- Option 4 - User can turn ON Output # 4
- Option 5 - User can turn ON Output # 5
- Option 6 - User can turn ON Output # 6
- Option 7 - User can turn ON Output # 7
- Option 8 - User can turn ON Output # 8

Any user can be allowed to turn an Output ON. This Function can be used to control external devices via the panel keypad with a User assigned to that Output. Once an Output is turned ON by a User, the Output can turn OFF again automatically if a reset time is assigned to the Output, or it can be turned off by the same user or by a different user with the next program location.

### User Can Turn an Output OFF

#### User Can Turn an Output OFF - P14e 1-100e

- Option 1 - User can turn OFF Output # 1
- Option 2 - User can turn OFF Output # 2
- Option 3 - User can turn OFF Output # 3
- Option 4 - User can turn OFF Output # 4
- Option 5 - User can turn OFF Output # 5
- Option 6 - User can turn OFF Output # 6
- Option 7 - User can turn OFF Output # 7
- Option 8 - User can turn OFF Output # 8

Any user can be allowed to turn an Output OFF. This Function can be used to control external devices via the panel keypad with a User assigned to that Output. Once an Output is turned OFF by a User, the Output can be turned on by the same user or by a different user with the previous program location.

## Radio Pendant Panic Alarm to Output

#### RADIO PENDANT PANIC ALARM to OUTPUT - P15E 21-100E (NOTE: only Users 21-100 can be Radio Users)

- Option 1 - A Pendant Panic Alarm will Operate Output # 1
- Option 2 - A Pendant Panic Alarm will Operate Output # 2
- Option 3 - A Pendant Panic Alarm will Operate Output # 3
- Option 4 - A Pendant Panic Alarm will Operate Output # 4
- Option 5 - A Pendant Panic Alarm will Operate Output # 5
- Option 6 - A Pendant Panic Alarm will Operate Output # 6
- Option 7 - A Pendant Panic Alarm will Operate Output # 7
- Option 8 - A Pendant Panic Alarm will Operate Output # 8

If a Radio Pendant is programmed to create a Panic Alarm (see P8E), when the Panic Alarm is activated it can be silent or it can turn on an Output. This option would normally be used to turn on any internal and/or external audible alarms connected to Outputs during a Pendant Panic Alarm.

# Learn Find and Delete Radio Key Codes and Tags

## Learn Radio Pendant Codes – pendant learn

**LEARN RADIO PENDANT CODES** - P18E 21-100E (NOTE: only Users 21-100 can be Radio Pendants)

A Radio Pendant must be enrolled into the panel before it can be used.

To learn a Radio Pendant you must first have a compatible receiver connected to the panel keypad buss. With the receiver connected and the panel in program mode, entering P18E then the pendant number you wish to enrol, eg 21E for pendant 21, the keypad will start to beep to indicate that learn mode has been started and the LED on the receiver will flash. Now operate the pendant you wish to learn into User slot 21. Once the transmitted code has been received by the panel and saved as pendant 21, the keypad will stop beeping and the LED on the receiver will stop flashing.

When learning a new radio code the panel checks all possible locations (including radio zones) before saving the new code to ensure that the code has not already been loaded into another slot. If the code already exists, the keypad will indicate which slot the code is already installed at. A number from 1-16 indicates a zone slot and a number from 21-100 indicates a user slot.

## DELETE a RADIO PENDANT CODE

**DELETE a RADIO PENDANT CODE** - P19E 21-100E (NOTE: only Users 21-100 can be Radio Pendants)

If you wish to delete a single Radio Pendant, pressing P19E then the User number while in Program Mode will delete the stored code against that User, eg P19E 21E will remove the code stored for User 21.

## FIND a RADIO PENDANT LOCATION

**FIND a RADIO PENDANT LOCATION** - P20E 0E (NOTE: only Users 21-100 can be Radio Pendants)

If you have a Radio Pendant loaded into the panel but are unsure which location (User #), pressing P20E (then 0E on an LED Keypad) while in Program Mode will start "Find" Mode. There is no need to press 0E when using an LCD keypad because the keypad will give you written prompts after entering P20E. The keypad will start to beep to indicate that "Find" mode has been started and the LED on the Receiver will flash. Now press the Radio Pendant button that you wish to find. If the Radio Pendant is in memory the keypad will display the number (1-16 indicates a zone, and 21-100 indicates a user). The keypad will stop beeping and the LED on the Receiver will stop flashing.

## LEARN ACCESS TAG/CARD CODES

### LEARN ACCESS TAG/CARD CODES - P21E 1-100E

An Access Tag/Card must be enrolled into the panel before it can be used. The panel can have up to 100 proximity tags (key-ring style card), or proximity cards loaded into the system. The tags or cards are stored separately to the User Codes but they follow the options of Users 1-100 programmed at locations P2E, P3E, P4E, P9E, P10E, P12E, P13E & P14E. For example if user 11 is assigned to area A (P3E Option 1), and can arm/disarm the alarm (P4E Options 1 & 3), then access Tag/Card number 11 will arm/disarm area A also.

To learn an Access Tag/Card you must first have a compatible proximity reader connected to the panel keypad buss. With the reader connected and the panel in program mode, entering P21E then the Access tag/card number you wish to enrol, eg 11E for Tag/Card number 11, the keypad will start to beep to indicate that learn mode has been started. Now present the Access Tag/card to the reader. Once the Tag/Card number has been received by the panel and saved, the keypad will stop beeping to indicate learn mode has stopped.

When learning a new access Tag/Card the panel checks all possible locations before saving the new code to ensure that the code has not already been loaded. If the tag or card already exists, the panel will not terminate learn mode but instead it will continue looking for a new tag or card to be presented. This allows a new tag or card to be learnt while existing tags or cards may be in use on the system.

After learning the tag or card, before it will work you MUST select the appropriate option at location P2E (options 2, 3 or 4 must be selected for the tag to work).

## DELETE an ACCESS TAG/CARD CODE

### DELETE an ACCESS TAG/CARD CODE - P22E 1-100E

If you wish to delete a single Access Tag or Card, pressing P22E then the User number while in Program Mode will delete the stored code against that User, eg P22E 11E will remove the tag or Card stored for User 11.

## FIND an ACCESS TAG/CARD LOCATION

### FIND an ACCESS TAG/CARD LOCATION - P23E 0E

If you have an Access Tag or Card loaded into the panel but are unsure which location (User #), pressing P22E (then 0E on an LED Keypad) while in Program Mode will start "Find" Mode. There is no need to press 0E when using an LCD keypad because the keypad will give you written prompts after entering P22E. The keypad will start to beep to indicate that "Find" mode has been started. Now present the Access Tag or Card you wish to find to a proximity reader connected to the panel. If the Tag or Card is in memory the keypad will display the number where the Tag or Card is stored (a number from 1-100). The keypad will stop beeping once the memory location has been found.

# Miscellaneous Panel & Clock Settings

## Installer Code

### INSTALLER CODE - P25E 1E

This code is used to enter full Installer Program mode (Program LED flashing on LED Keypad). The default installer code is 000000. This code can only be changed while in Installer Program Mode. To enter your new installer code press P25E1E. The existing code will be displayed at the keypad (either each digit flashed out sequentially on an LED keypad or shown on the bottom line of the LCD keypad). To change the code simply enter the digits of the new code and it will replace the old one. The Installer Code must be between 4-6 digits in length.

## Duress Digit

### DURESS DIGIT - P25E 2E (Value can be 1-9, 0 = Duress Disabled)

The duress digit can be a number from 1-9 (a value of "0" means the duress function is disabled).

To create a duress alarm the duress digit must be entered before a valid user code (eg If the code was "123" and the duress number was "4", then entering a code of <4123> <ENTER> would create a duress alarm).

## Dial Reporting Delay

### DIAL REPORTING DELAY - P25E 3E (0-255 Seconds)

If this address is set to 0, there will be no report delay. If it is set to any value other than 0 then a delay equal to the programmed value will stop the panel from reporting an alarm until this delay time expires.

## Radio Zone Supervised Timer

### SUPERVISED TIMER

#### RADIO ZONE SUPERVISED TIMER - P25E 4E (Value 0-9999 Minutes)

If a radio detector is capable of sending regular supervisory signals to the panel and the zone type is set for "Supervised Signal Active", this timer sets how long a period has to elapse with no received transmissions before a supervisory failure alarm is generated.

## Two Trigger Timer

**TWO TRIGGER TIMER** - P25E 5E (0-255 Seconds)

If a zone is set to two trigger, the zone has to cause an alarm twice within the two trigger time period to cause an alarm. If multiple zones are set to two trigger, an alarm will be generated if two zones trigger once each within the two trigger time period. If a two trigger zone goes into alarm but remains in alarm for longer than the two trigger time period (ie detector failure or cable cut) an alarm will be generated.

## Mains Fail Reporting Delay

### AC Fail delay

**MAINS FAIL REPORTING DELAY** - P25E 6E (0-9999 Seconds)

If a Mains Failure occurs this timer delays the reporting of Mains Failure to a Monitoring Station. If the mains power returns before the timer expires, then no report is sent. If Mains Failure is assigned to an output, this delay must expire before the output will turn on.

## Receiver Fail Delay/Timer

### Radio Reset Time

**RECEIVER FAIL DELAY** - P25E 7E (0-9999 Seconds)

If supervised radio detectors are used, the receiver will be seeing regular transmissions. Because of this, the panel can monitor receiver activity to check that the receiver is still working. If the panel does not receive any signals within this time period a receiver failure alarm will be generated. If set to 0, the receiver monitoring will be turned off.

## Upload/Download Site Code Number

### Security Code

**UPLOAD/DOWNLOAD SITE CODE NUMBER** - P25E 8E (8 characters)

The upload/download site code number must be entered if the panel is set for auto-answer as this provides a security access level to the panel. The number can be up to 8 characters in length. Valid characters for this number are 0-9,B-F. See chart on page 76 for details of how to program the characters B-F.

## Temporary Output Disable

**TEMPORARY OUTPUT DISABLE** - P25E 9E (Select output # 1-8)

This address allows a technician to select any output/s to be temporarily disabled for one alarm or armed cycle, eg by selecting LEDES 1-4 (Outputs 1-4) at this location then leaving program mode, outputs 1-4 will not turn on following any alarms. The technician is now free to arm the system to test all monitoring signals without having any internal and/or external alarms activating. When the alarm is reset or disarmed all outputs will now work normally again.

## Miscellaneous Installer and Panel Options

### MISCELLANEOUS PANEL OPTIONS - P25E 10E

Option 1 - Panel Tamper is 2k2 EOL

Option 2 - Direct access to program mode for the Installer Code

Option 3 - Disable Mains Fail Test

Option 4 - Listen-in to O/P # 1 Low Volume

Option 5 - Receiver Fail Lockout

Option 6 - Send Output information to Keypad Buss

Option 7 - Cannot Arm if the System Battery is Low

Option 8 - Installer Lockout

Option 1 **Panel Tamper is 2k2 EOL** - The Tamper input (Tmp) on the control panel requires either a short circuit or a 2k2 End-of-Line resistor. If option 1 is on the panel must see a 2k2 resistor (EOL) across the Tmp & 0V terminals to ensure the tamper is sealed. If this option is turned off then a simple short circuit is all that is required to seal the panel tamper.

Option 2 **Direct access to program mode for the Installer Code** - If this option is on, the Installer Code can gain access to Installer Program Mode directly. If the option is turned off, the installer can only gain access to Installer Program Mode via Client Program Mode. This option allows the owner to control program mode access by the installer. The User must have option 3 at location P5E turned on for them to allow installer access.

Option 3 **Disable Mains Fail Test** - If the panel must be run off a DC supply or the Mains supply can fail regularly, this option disables the mains voltage monitoring to prevent mains fail alarms from occurring.

Option 4 **Listen-in to O/P # 1 Low Volume** - If Listen-In to Output 1 is turned on (P175E8E), the level of sound from the speaker can be controlled with this option. If this option is Off the sound level during listen-in to O/P 1 is high volume, turning this option On makes the sound level low volume. For listen-in to Output 1 to work the device connected to O/P 1 must be an 8Ω speaker and the output must be modulated (P35E1E Option 1 on). Failure to do this could result in damage to the speaker & output.

Option 5 **Receiver Fail Lockout** - If the receiver fail delay (P25E7E) is set to a value other than 0 and the panel sees no activity from the receiver for the set period of time, a receiver fail alarm will be generated. If this option is turned on, the panel cannot be armed until the cause of the receiver failure has been resolved.

Option 6 **Send Output information to Keypad Buss** - There is an optional 4 x relay output expander board that can be connected to the keypad buss if required. For this output expander to work option 6 must be turned on for the data to be sent on the keypad buss to the expander.

Option 7 **Cannot Arm if System battery is Low** - If the panel battery is low, normally you can arm the panel leaving the battery to charge over a period of time. If this option is turned on, the panel cannot be armed until the battery is either fully charged again, or it has been replaced (if faulty).

Option 8 **Installer Lockout** - Normally if the panel is powered up with the panel tamper open (ie system tamper alarm active) and in the Disarm state, then the panel will go into installer program mode when the <PROGRAM> then <ENTER> buttons are pressed. If this option is on, the panel will not allow access to program mode on power-up and the only valid method of accessing program mode is via the installer code.

## INSTALLER OPTIONS

### INSTALLER OPTIONS - P25E 11E

Option 1 - Entry to Installer Mode Resets Confirmed Alarms

Option 2 - Entry to Installer Mode Resets Tamper Alarms

Option 3 - Entry to Installer Mode Resets Low Battery Alarm

Option 4 - Entry to Installer Mode Resets Supervisory Alarms

Option 5-7 - Spare

Option 8 - User Codes Must be 4-6 digits long

Option 1 **Entry to Installer Mode Resets Confirmed Alarms** - If this option is turned on and a Confirmed alarm has occurred, the alarm cannot be re-armed until the Installer has reset the alarm. The Installer must access Installer Program Mode via Client Mode to reset the system. The zones that caused the alarm will latch on (even when disarmed) until reset by the installer to indicate that lockout is in effect.

Option 2 **Entry to Installer Mode Resets Tamper Alarms** - If this option is turned on and a Tamper alarm has occurred (system or zone tampers), the alarm cannot be re-armed until the Installer has reset the alarm. The Installer must access Installer Program Mode via Client Mode to reset the system. The Trouble indication will latch on (even if the tamper alarm has been cleared) until reset by the installer to indicate that lockout is in effect.

Option 3 **Entry to Installer Mode Resets Low Battery Alarm** - If this option is turned on and a Low Battery alarm has occurred, the Installer must access Installer Program Mode via Client Mode to reset the battery low signal. If option 7 is turned on at location P25E10E the alarm cannot be re-armed until the Installer has reset the battery low signal.

Option 4 **Entry to Installer Mode Resets Supervisory Alarms** - If this option is turned on and a Detector Supervisory alarm has occurred, the alarm cannot be re-armed until the Installer has reset the alarm. The Installer must access Installer Program Mode via Client Mode to reset the supervisory alarm.

Option 8 **User Codes Must be 4-6 Digits** - If this option is turned on, all User Codes must be between 4-6 digits long. If it is turned off, the User Codes can be 1-6 digits long.

## Hide User Codes - USER OPTIONS

### USER OPTIONS - P25E 12E (NOTE: This Option can ONLY be accessed from Client Mode)

Option 1 **Hide User Codes from Installer** - This option is only accessible from Client Program Mode. It is designed to allow the User (owner) of the alarm to hide their User Codes from the Installer if desired. If this option is turned On, codes can only be changed or viewed in Client program mode. Users **MUST** have option 2 at location P5E assigned before they can hide the user codes.

## Setting Time, Date and Daylight Saving

### Setting Real Time Clock

<b>REAL TIME CLOCK HOUR/MINUTE</b> -	P26E 1E (Value 0-2359)
<b>REAL TIME CLOCK DAY of WEEK</b> -	P26E 2E (Value 1-7) [where 1 =Sunday, 2 = Monday, 3 = Tuesday, etc]
<b>REAL TIME CLOCK DATE/MONTH/YEAR</b> -	P26E 3E (Value DDMMYY) for example 020904 = 2nd September, 2004

The Real Time Clock controls the Time-zones, the timing of automatic test calls and is used to Time & Date stamp the events in the Event Buffer. Ensure this is set correctly at the time of installation so that the all of the functions using the time have will work correctly. The clock is programmed in 24 hour format (eg 00:00-23:59).

### Daylight Saving (DLS) Settings

**DAYLIGHT SAVING ACTIVE** - P26E 4E (If LED # 1 is On, Daylight Saving is currently active)

**NOTE:** If you are in Daylight Saving Time when the alarm system is installed you **MUST** turn on option 1 at location P26E4E so that the panel knows that Daylight Saving Time is currently active. Failure to do this will not allow the clock to automatically adjust to the correct time when Daylight Saving Time Ends.

<b>DAYLIGHT SAVING START SUNDAY</b> -	P27E 1E (Value 0-5, 0= DLS Disabled)
<b>DAYLIGHT SAVING END SUNDAY</b> -	P27E 1E (Value 0-5, 0= DLS Disabled)
<b>DAYLIGHT SAVING START MONTH</b> -	P28E 1E (Value 1-12)
<b>DAYLIGHT SAVING END MONTH</b> -	P28E 1E (Value 1-12)
<b>DAYLIGHT SAVING START HOUR</b> -	P29E 1E (Value 0-23)
<b>DAYLIGHT SAVING END HOUR</b> -	P29E 1E (Value 0-23)

If Daylight Saving (DLS) is used, the actual start and stop details can be entered here and the clock will automatically adjust for daylight saving.

# Outputs

## NOTE:

**With all output programming options we refer to outputs 1-8. Only outputs 1-4 are available as standard, with outputs 5-8 requiring the connection of the optional 4 way output expander unit that connects to the keypad buss ( the output expander provides 4 change-over relay contacts).**

## OUTPUT OPTIONS

### OUTPUT OPTIONS "A"

#### OUTPUT OPTIONS "A" - P34E 1-8E

Option 1 - Invert Output

Option 2 - Flash Output

Option 3 - Single Pulse to Output

Option 4 - Lockout Output

Option 5 - DTMF Remote Control of Output

Option 6 - Keypad User can Operate Output

Option 7 - <CONTROL> button can Operate Output

Option 8 - Pulsed Chime Alarm (linked to pulse timer)

Option 1 **Invert Output** - This option is used to invert the normal state of the output. The panel uses open collector transistor switches and the default state of all outputs is off (open). When in alarm the transistor is turned on and the output goes low (OV). The invert option reverses this function.

Option 2 **Flash Output** - When the output is turned on this option causes the output to flash at a rate set by the pulse timer (P39E). One use is to flash a lamp during an alarm. **DO NOT** turn this option on if the Output is to be manually controlled by a user or the "Control" button.

Option 3 **Single Pulse to Output** - This option produces a single pulse at the output when an alarm occurs (the pulse time is the value programmed at the output pulse timer P39E).

Option 4 **Lockout Output** - This option is used to limit the output to one operation per arming period.

Option 5 **DTMF Remote Control of Output** - If the panel is set-up so a User can dial in from a remote telephone to perform "DTMF Code Control" (P175E12E) of the Outputs, this option selects which Outputs are able to be controlled by the remote user.

Option 6 **Keypad User can Operate Output** - If a DTMF Output control code is programmed into the panel (P175E12E), the same code can be entered at the panel keypad to allow local control of the Outputs selected at this address.

Option 7 **<Control> button can Operate Output** - The <Control> button on the keypad can also be used to turn outputs on or off. For that to happen this option must be turned on for the output/s concerned. To turn an output on locally at the keypad the operator simply presses the <Control> button for 2 seconds at which time the "Control" LED will illuminate on an LED keypad or the word "OUTPUTS" will appear on the LCD keypad to indicate that the Control mode is active. If any controllable outputs are currently on they will be indicated at the keypad. The operator can now press a button relating to the output/s they wish to control eg pressing the "1" button will turn output 1 on or off, The "2" button for output 2 etc. When finished the

operator then presses the <ENTER> button to cancel the Control mode and return to normal.

- Option 8 **Pulsed Chime Mode Alarm** - Chime Zones programmed to this output will turn the output on for the duration of the Chime to Output time period (P41E). If this option is on the output will pulse at the pulse timer rate (P39E) for the duration of the chime zone to output timer (P41E).

## OUTPUT OPTIONS "B"

### OUTPUT OPTIONS "B" - P35E 1-8E

Option 1 - Mains Fail to Output

Option 2 - Fuse Failure to Output

Option 3 - Battery Low to Output

Option 4 - Telephone Line Failure to Output

Option 5 - Supervisory Radio Failure to Output

Option 6 - Sensor-Watch Alarm to Output

Option 7 - System Tamper to Output

Option 8 - Receiver Fail to Output

- Option 1 **Mains Fail to Output** - This option is used to assign a Mains Fail alarm to an Output.
- Option 2 **Fuse Failure to Output** - This option is used to assign a Fuse Failure alarm to an Output. The on-board fuses are thermally activated. If excessive current is drawn from a fuse it will disconnect the power until the problem is resolved. There are two thermal fuses protecting the various 12v DC outputs.
- Option 3 **Battery Low to Output** - This option is used to assign a Battery Low alarm to an Output.
- Option 4 **Telephone Line Failure to Output** - This option is used to assign a Telephone Line Failure alarm to an Output.
- Option 5 **Supervisory Radio failure to Output** - This option is used to assign a Radio Detector Supervisory Fail alarm to an Output.
- Option 6 **Sensor-Watch Alarm to Output** - This option is used to assign a Sensor-Watch alarm to an Output. A Sensor-Watch alarm occurs when a detector has not operated within a set period of time.
- Option 7 **System Tamper to Output** - This option is used to assign a panel tamper alarm to an Output.
- Option 8 **Receiver Fail to Output** - If the receiver fail timer expires (see P25E7E) this option will assign the alarm to an Output.

## OUTPUT OPTIONS "C"

### OUTPUT OPTIONS "C" - P36E 1-8E

Option 1 - Walk-test Pulse to Output

Option 2 - Pulse Output every 5 seconds when Disarmed

Option 3 - Pulse Output on Kiss-off Following Arming

- Option 1 **Walk-test Pulse to Output** - When the panel is in Walk-test Mode, this option assigns a pulse to the Output every time a zone is triggered. The pulse is linked to the Output Pulse time (P39E).
- Option 2 **Pulse Output every 5 seconds when Disarmed** - This option will cause the Output to pulse every 5 seconds when the panel is disarmed. The pulse time is linked to the Output Pulse time (P39E).
- Option 3 **Pulse Output on Kiss-off Following Arming** - This option will cause the Output to pulse for 2 seconds when the panel is armed and the message has been kissed off by the monitoring company. The pulse time is linked to the Output Pulse time (P39E) which is defaulted to 2 seconds.

## OUTPUT OPTIONS "D"

### OUTPUT OPTIONS "D" - P37E 1-8E

Option 1 - Siren Driver to Output (applies to O/P 1&2 only, requires an 8Ω speaker)

Option 2 - Output Reset Time is in Minutes

Option 3 - Output "Silenced" for 10 seconds on key-press

Option 4 - Spare

Option 5 - Spare

Option 6 - Spare

Option 7 - Spare

Option 8 - Output Monitored (applies to O/P 1&2 only)

Option 1 **Siren Driver to Output** - This option is used to assign a Modulated Siren tone to an Output. The option only applies to Outputs 1 and 2. For the modulated siren tone to work correctly, an 8Ω speaker must be connected to the output concerned. Outputs 1 and 2 have different sounds so that a user can tell which output is operating.

Option 2 **Output Reset Time is in Minutes** - The Output reset time (P40E) is normally in seconds. This means that the Output timing can be set from 1-9999 seconds (approximately 2.8 hours). If a longer time period is required, by turning this option on the reset time is calculated in minutes (eg 1-9999 minutes allowing up to 166.65 hours).

Option 3 **Output "Silenced" for 10 seconds on key-press** - When the alarm is Armed and activated it can be difficult sometimes to turn the alarm off because you are unable to hear the beeps as you enter you code at the keypad. If this option is turned on the selected output/s will silence (turn off) for 10 seconds on the first button press at any keypad. This should allow easy Disarming of the alarm by a valid User. If the alarm is not turned off within the 10 seconds, the outputs will turn on again. This function will only work once during an Armed cycle and the panel must be Disarmed before it will work again.

Option 8 **Output Monitored** - This option is used to allow Monitoring of the Output status (eg wire to siren has been cut). The option only applies to Outputs 1 and 2.

## Output On Delay, Pulse, Reset and Chime Times

### Output On Delay Time

**OUTPUT ON DELAY TIME** - P38E 1-8E (0-9999 Seconds, 0 = no delay)

The "On" delay allows the operation of the Output to be delayed by the time programmed at this location. If set to "0" there will be no on delay and the Output will operate the instant it is turned on.

### Output Pulse Time ( Flash Time )

**OUTPUT PULSE TIME** - P39E 1-8E (0-255 1/10th Seconds, eg 20 = 2 secs)

The Pulse time affects the time the output turns on when the pulse timer is used on the Output. The pulse time is in 1/10th second increments so that very quick timing can be achieved. Functions like radio key Arm/Disarm Chirps to an Output or a flashing output (P34E option 2) all use the pulse timer. If access tags are assigned with the chirp function (P46E4E) and the LED on an access reader is set to follow an output with the chirps assigned (P98E) then this timer must be set to a minimum value of 10 for the reader LED to display the chirps.

## Output Reset Time

**OUTPUT RESET TIME** - P40E 1-8E (0-9999 Seconds, 0 = latched output)

The Reset time affects the time the output turns on when an alarm is active. The default range is 0-9999 seconds but if option 2 at location P37E is on the range is 0-9999 minutes.

## Chime Mode Time

**CHIME MODE TIME** - P41E 1-8E (0-255 1/10th Seconds, eg 20 = 2 secs)

The Chime Mode time affects the time the output turns on when a Chime Zone is activated. The Chime time is in 1/10th second increments so that very quick timing can be achieved.

# Output Voice Board Remote Control Start Messages

## Start of "DTMF Output Control" Status Messages

**START OF "DTMF OUTPUT CONTROL" STATUS MESSAGES** - P42E 1-8E (0-99)

If a Voice Board is connected to the panel it is possible to dial the panel from a remote telephone and turn outputs On or Off using a 4 digit code with voice prompts provided by the Voice Board to identify what function you are controlling. Please see Voice Board programming on Page 11 for more details.

## Un-Map an Output

**UN-MAP OUTPUTS** - P43E 1-8E

If you are using an Output for a special purpose and do not need the standard defaults assigned to that output you can remove all defaults at this location. For example if you are using output number 4 to open a door via a Radio Key and you don't want any alarms to be assigned to the output press P43E4E and ALL defaults will be removed. This removes all options assigned to the output and makes the reset time "0" for latched operation.

## Assigning a Time-Zone to an Output

**ASSIGN A TIME-ZONE TO OUTPUTS** - P44E 1-8E (O/P#) Value = Time-zone 1-8

Any of the 8 Time-zones can be assigned to outputs 1-8. If a time-zone is assigned to an output it will turn the output on when the T/Z starts and turn the output off when the T/Z ends. You should un-map the output at P43E first before assigning the T/Z to ensure that only the T/Z will control the state of the output.

# Areas

## Area Arm and Special Function Options

### Area Options "A"

**AREA OPTIONS "A"** - P45E 1-2E (1 = Area A, 2 = Area B)

Option 1 - <ARM> button Required Before Code to Arm

Option 2 - <STAY> button Required Before code to Arm Stay Mode

Option 3 - <CODE> Required to Arm

Option 4 - <CODE> Required to Bypass

Option 5 - Spare

Option 6 - Report Arm Signal at the end of the Exit Delay

Option 7 - Can Arm only if All Zones Sealed (Ready)

Option 8 - Can Arm Stay Mode only if All Zones Sealed (Ready)

Option 1     **<ARM> button Required Before Code to Arm** - This option determines if the <ARM> button must be pressed before a code is entered to Arm an Area. If a User has access to both Areas and this option is turned on, the special keypad arming functions described on Page 45 will apply.

Option 2     **<STAY> button Required Before Code to Arm Stay Mode** - This option determines if the <STAY> button must be pressed before a code is entered to Arm Stay Mode. If a User has access to both Areas and this option is turned on, the special keypad arming functions described on Page 45 will apply.

Option 3     **<CODE> Required to Arm** - If this option is turned on, the <ARM> button is disabled and the panel requires a code to Arm.

Option 4     **<CODE> Required to Bypass** - If this option is turned on, the <BYPASS> button cannot access Bypass Mode directly. To enter Bypass mode the User must press <BYPASS> <CODE> <ENTER> before they can bypass zones.

Option 5     **Spare**

Option 6     **Report Arm Signal at the end of the Exit Delay** - If this option is on the panel will report the Arm signal to a monitoring station when the exit delay expires. If it is off, the panel will report the arm signal immediately the system has been armed.

Option 7     **Can Arm only if All Zones Sealed (Ready)** - If this option is on it stops the panel from arming an area with an unsealed zone (Not Ready). If off, the panel can be armed if the Ready LED is not on.

Option 8     **Can Arm Stay Mode only if All Zones Sealed (Ready)** - If this option is on it stops the panel from arming stay mode if an area has an unsealed zone (Not Ready). If off, the panel can be arm stay mode if the Ready LED is not on.

## Area Options "B"

### AREA OPTIONS "B" - P46E 1-2E (1 = Area A, 2 = Area B)

Option 1 - Use Near and Verified Alarm reporting for All zones in this Area

Option 2 - Area will Arm at the end of Time-Zone

Option 3 - Area will Disarm at the end of Time-Zone

Option 4 - Assign Chirps to Access tags

Option 5 - Spare

Option 6 - Spare

Option 7 - Spare

Option 8 - Spare

#### *Option 1*

**Use Near and Verified Alarm reporting for All zones in this Area** - To reduce the possibility of false alarms the panel can require two alarms on different zones within a 45 minute period before a full alarm will be sent. If this option is turned on it applies to all zones assigned to that area. An alarm on a single zone will send a Near Alarm report to the monitoring station. If no further alarms occur within 45 minutes the near alarm timer is reset and a restore is sent for the zone that activated. If the zone that activated is still in alarm when the 45 minute timer expires, a zone bypass for that zone will be sent and the zone will remain bypassed until the area is disarmed. Any new alarms after the timer has expired will send another Near Alarm report. If a second alarm on a different zone occurs within 45 minutes of the Near alarm, an Intrusion Verified alarm report will be sent. This format only applies to Contact ID and Pager reporting. Turning this option on will stop zone alarms from being reported in Domestic & Voice formats as there are no messages for near and confirmed alarms. You must turn this option off if using Domestic or Voice formats.

#### *Option 2*

**Area will Arm at the end of Time-Zone** - The panel is capable of automatically arming on a Time-Zone. If this option is turned on and a Time-Zone is selected at P68E, the Area will automatically arm when the Time-Zone ends. If the panel cannot arm because it is not "Ready", a fail to arm report will be sent.

#### *Option 3*

**Area will Disarm at the end of Time-Zone** - The panel is capable of automatically disarming on a Time-Zone. If this option is turned on and a Time-Zone is selected at P68E, the Area will automatically disarm when the Time-Zone starts.

#### *Option 4*

**Assign Chirps to Access Tags** - If the panel is being Armed or Disarmed by an Access Tag/Card from a proximity reader it is possible to link the pendant chirps programming (P50E-P53E) to Arming or Disarming via the Access Tag or Card. If this option is On the chirps will apply to Access Tag/Cards. If the chirps are required to be displayed at the reader LED, the minimum pulse timer for the output (P39E) must be a value of 10.

## Area Arm/Stay Pulse & Chirps to Outputs

### Area Arm Indication to Output ( Arm Follow )

**AREA ARM INDICATION to OUTPUT - P47E 1-2E** (1 = Area A, 2 = Area B)

Option 1 - Output 1      Option 5 - Output 5  
Option 2 - Output 2      Option 6 - Output 6  
Option 3 - Output 3      Option 7 - Output 7  
Option 4 - Output 4      Option 8 - Output 8

For monitoring purposes an Arm indication can be assigned to an Output. Each Area can have a separate arm indication assigned to a different output if required.

### Area Stay Arm Indication to Output ( Stay Follow )

**AREA STAY ARM INDICATION to OUTPUT - P48E 1-2E** (1 = Area A, 2 = Area B)

Option 1 - Output 1      Option 5 - Output 5  
Option 2 - Output 2      Option 6 - Output 6  
Option 3 - Output 3      Option 7 - Output 7  
Option 4 - Output 4      Option 8 - Output 8

For monitoring purposes a Stay Arm indication can be assigned to an Output. Each Area can have a separate indication assigned to a different output if required.

### Area Disarm Indication to Output ( Open Follow )

**AREA DISARM INDICATION to OUTPUT - P49E 1-2E** (1 = Area A, 2 = Area B)

Option 1 - Output 1      Option 5 - Output 5  
Option 2 - Output 2      Option 6 - Output 6  
Option 3 - Output 3      Option 7 - Output 7  
Option 4 - Output 4      Option 8 - Output 8

For monitoring purposes a Disarm indication can be assigned to an Output. Each Area can have a separate disarm indication assigned to a different output if required.

### Pendant Arm Chirp to Output

**PENDANT ARM CHIRP to OUTPUT - P50E 1-2E** (1 = Area A, 2 = Area B)

Option 1 - Output 1      Option 5 - Output 5  
Option 2 - Output 2      Option 6 - Output 6  
Option 3 - Output 3      Option 7 - Output 7  
Option 4 - Output 4      Option 8 - Output 8

When Arming the alarm using a Radio Key it is necessary to have some form of Arm indication. This can be done by pulsing an Output once when the area is armed (one chirp). The Chirp is linked to the pulse time (P39E) for the output concerned. If Output 1 or 2 are used for the chirp and a horn speaker is connected to the output (see P37E1 or 2E option 1), the siren on the output will give a single tone for the chirp instead of the swept tone used for alarms. Also Arming via an Access Tag/Card can generate the Chirp if option 4 is On at P47E.

## Pendant Stay Mode Arm Chirp to Output

**PENDANT STAY MODE ARM CHIRP to OUTPUT - P51E 1-2E** (1 = Area A, 2 = Area B)

- |                     |                     |
|---------------------|---------------------|
| Option 1 - Output 1 | Option 5 - Output 5 |
| Option 2 - Output 2 | Option 6 - Output 6 |
| Option 3 - Output 3 | Option 7 - Output 7 |
| Option 4 - Output 4 | Option 8 - Output 8 |

When Arming Stay Mode using a Radio Key it is necessary to have some form of Arm indication. This can be done by pulsing an Output once when the area is armed (one chirp). The Chirp is linked to the pulse time (P39E) for the output concerned. If Output 1 or 2 are used for the chirp and a horn speaker is connected to the output (see P37E1 or 2E option 1), the siren on the output will give a single tone for the chirp instead of the swept tone used for alarms. Also Stay Arming via an Access Tag/Card can generate the Chirp if option 4 is On at P47E.

## Pendant Disarm Chirp to Output ( Open Chirp )

**PENDANT DISARM CHIRP to OUTPUT - P52E 1-2E** (1 = Area A, 2 = Area B)

- |                     |                     |
|---------------------|---------------------|
| Option 1 - Output 1 | Option 5 - Output 5 |
| Option 2 - Output 2 | Option 6 - Output 6 |
| Option 3 - Output 3 | Option 7 - Output 7 |
| Option 4 - Output 4 | Option 8 - Output 8 |

When Disarming the alarm using a Radio Key it is necessary to have some form of Disarm indication. This can be done by pulsing an Output twice when the area is disarmed (two chirps). The Chirps are linked to the pulse time (P39E) for the output concerned. If Output 1 or 2 are used for the chirp and a horn speaker is connected to the output (see P37E1 or 2E option 1), the siren on the output will give a single tone for the chirp instead of the swept tone used for alarms. Also Disarming via an Access Tag/Card can generate the Chirp if option 4 is On at P47E.

## Pendant Stay Mode Disarm Chirp to Output

**PENDANT STAY MODE DISARM CHIRP to OUTPUT - P53E 1-2E**

(1 = Area A, 2 = Area B)

- |                     |                     |
|---------------------|---------------------|
| Option 1 - Output 1 | Option 5 - Output 5 |
| Option 2 - Output 2 | Option 6 - Output 6 |
| Option 3 - Output 3 | Option 7 - Output 7 |
| Option 4 - Output 4 | Option 8 - Output 8 |

When Disarming Stay Mode using a Radio Key it is necessary to have some form of Disarm indication. This can be done by pulsing an Output twice when the Stay Mode is disarmed (two chirps). The Chirps are linked to the pulse time (P39E) for the output concerned. If Output 1 or 2 are used for the chirp and a horn speaker is connected to the output (see P37E1 or 2E option 1), the siren on the output will give a single tone for the chirp instead of the swept tone used for alarms. Also Stay Mode Disarming via an Access Tag/Card can generate the Chirp if option 4 is On at P47E.

## Arm Pulse to Output

**ARM PULSE to OUTPUT** - P54E 1-2E (1 = Area A, 2 = Area B)

- Option 1 - Output 1
- Option 2 - Output 2
- Option 3 - Output 3
- Option 4 - Output 4
- Option 5 - Output 5
- Option 6 - Output 6
- Option 7 - Output 7
- Option 8 - Output 8

Sometimes it is necessary to have a single pulse to indicate an Arm state. This could be used to start a video recorder or similar device. Each time an Area is armed, a single pulse will be applied to the output. The Pulse time (P39E) sets the length of the pulse.

## Stay Mode Arm Pulse to Output

**STAY MODE ARM PULSE to OUTPUT** - P55E 1-2E (1 = Area A, 2 = Area B)

- Option 1 - Output 1
- Option 2 - Output 2
- Option 3 - Output 3
- Option 4 - Output 4
- Option 5 - Output 5
- Option 6 - Output 6
- Option 7 - Output 7
- Option 8 - Output 8

Sometimes it is necessary to have a single pulse to indicate that Stay Mode is Armed. This could be used to start a video recorder or similar device. Each time an Area Stay Mode is armed, a single pulse will be applied to the output. The Pulse time (P39E) sets the length of the pulse .

## Disarm Pulse to Output ( Open Pulse )

**DISARM PULSE to OUTPUT** - P56E 1-2E (1 = Area A, 2 = Area B)

- Option 1 - Output 1
- Option 2 - Output 2
- Option 3 - Output 3
- Option 4 - Output 4
- Option 5 - Output 5
- Option 6 - Output 6
- Option 7 - Output 7
- Option 8 - Output 8

Sometimes it is necessary to have a single pulse to indicate a Disarm state. This could be used to stop a video recorder or similar device. Each time an Area is disarmed, a single pulse will be applied to the output. The Pulse time (P39E) sets the length of the pulse.

## Stay Mode Disarm Pulse to Output ( Un-stay Pulse )

**STAY MODE DISARM PULSE to OUTPUT** - P57E 1-2E (1 = Area A, 2 = Area B)

- Option 1 - Output 1
- Option 2 - Output 2
- Option 3 - Output 3
- Option 4 - Output 4
- Option 5 - Output 5
- Option 6 - Output 6
- Option 7 - Output 7
- Option 8 - Output 8

Sometimes it is necessary to have a single pulse to indicate a Disarm of Stay Mode. This could be used to stop a video recorder or similar device. Each time an Area Stay Mode is disarmed, a single pulse will be applied to the output. The Pulse time (P39E) sets the length of the pulse.

## Armed Exit Delay Beeps to Keypad

**ARMED EXIT DELAY BEEPS TO KEYPAD** - P58E 1-2E (1 = Area A, 2 = Area B)

Option 1 - Keypad 1    Option 5 - Keypad 5  
Option 2 - Keypad 2    Option 6 - Keypad 6  
Option 3 - Keypad 3    Option 7 - Keypad 7  
Option 4 - Keypad 4    Option 8 - Keypad 8

When an Area is Armed it is useful to have the exit delay beeps occurring at the keypad to warn the User to exit the premises without delay. If the option is on at this address, that keypad will beep out the exit delay. The exit beeps occur at one second intervals until the last 5 seconds at which time they change to 1/2 second intervals to act as a warning that the delay is about to expire.

## Stay Mode Exit Delay Beeps to Keypad

**STAY MODE EXIT DELAY BEEPS TO KEYPAD** - P59E 1-2E (1 = Area A, 2 = Area B)

Option 1 - Keypad 1    Option 5 - Keypad 5  
Option 2 - Keypad 2    Option 6 - Keypad 6  
Option 3 - Keypad 3    Option 7 - Keypad 7  
Option 4 - Keypad 4    Option 8 - Keypad 8

When an Area is Armed in Stay Mode it is useful to have the exit delay beeps occurring at the keypad to warn the User to exit the premises without delay. If the option is on at this address, that keypad will beep out the exit delay. This option may be turned off for Stay Mode to make the keypad silent when arming at night time. The exit beeps occur at one second intervals until the last 5 seconds at which time they change to 1/2 second intervals to act as a warning that the delay is about to expire. When arming Stay Mode the exit and entry delays can be cancelled by pressing the <ENTER> button following arming of Stay Mode. The next time Stay Mode is armed, if the <ENTER> button is not pressed, all programmed exit and entry delays will apply.

## Armed Exit Delay Time

**ARMED EXIT DELAY TIME** - P60E 1-2E (1 = Area A, 2 = Area B) (Value 0-255 Seconds)

Each Area can have its own exit delay time. The delay can be programmed from 1-255 seconds in one second increments. If the exit delay is set to "0" the panel will be instantly armed.

## STAY MODE EXIT DELAY TIME

**STAY MODE EXIT DELAY TIME** - P61E 1-2E (1 = Area A, 2 = Area B) (Value 0-255 Seconds)

Each Stay Mode Area can have their own exit delay time. The delay can be programmed from 1-255 seconds in one second increments. If the exit delay is set to "0" the panel will be instantly armed.

## Monitoring Account Code Number

**MONITORING ACCOUNT CODE NUMBER** - P62E 1-2E (1 = Area A, 2 = Area B) (Value 0000-FFFF)

When the dialler is reporting to a monitoring station there must be a unique account code programmed to identify the panel. There is an account code for each area. The account code is 4 digits. Each digit can be a number from 0-9 as well as the special characters B,C,D,E & F. The chart below shows how the special characters are entered.

LED KEYPAD BUTTON	LED KEYPAD INDICATION	LCD KEYPAD BUTTON	LCD KEYPAD CID & 4+2 INDICATIONS	LCD KEYPAD TELEPHONE INDICATIONS	CID & 4+2 SPECIAL CHARACTERS	TELEPHONE NUMBER SPECIAL FUNCTION
"BYPASS"	-	CONTROL & 0	-	DELETE #	DELETE #	DELETE #
"PANIC"	11	CONTROL & 2	B	#	"B"	"#"
"MEMORY"	12	CONTROL & 3	C	*	"C"	"*"
"CONTROL"	13	CONTROL & 4	D	-	"D"	"2.5 sec Pause"
"ARM"	14	CONTROL & 5	E	w	"E"	"Wait for 2nd Dial-tone"
"STAY"	15	CONTROL & 6	F	=	"F"	"5 sec Pause"

## Remote Arm/Disarm DTMF Code & Start Voice Message

### DTMF Remote Control Code Number

**DTMF REMOTE CODE NUMBER** - P63E 1-2E (1 = Area A, 2 = Area B) (Value 1-4 digit code 0-9999)

The panel can be configured to allow remote Arm/Disarm of each Area via a remote telephone. The codes programmed at this address are the DTMF code that must be used when performing this function. When dialling the panel and it has answered the call, after waiting for the panel modem tones to stop you can enter in the 4 digit DTMF code and the current status will be given of the Area associated with the code entered. After that, if you press the "\*" button on the telephone the status of the area will toggle eg if it was previously armed it will change to disarmed or vice versa. When finished you simply hang-up and 15 seconds later the panel will release the line.

### Start of "DTMF Arm/Disarm" Status Messages

**START OF "DTMF ARM/DISARM" STATUS MESSAGES** - P64E 1-2E (1 = Area A, 2 = Area B) (0-99)

If a Voice Board is connected to the panel it is possible to dial the panel from a remote telephone and Arm or Disarm each Area using a 4 digit code with voice prompts provided by

the Voice Board to identify what Area you are controlling. Please see Voice Board programming on Page 11 for more details.

## Armed Exit Beeps to Output

**ARMED EXIT BEEPS to OUTPUT** - P65E 1-2E (1 = Area A, 2 = Area B)

Option 1 - Output 1      Option 5 - Output 5  
Option 2 - Output 2      Option 6 - Output 6  
Option 3 - Output 3      Option 7 - Output 7  
Option 4 - Output 4      Option 8 - Output 8

Sometimes it can be useful to extend the exit beeps, that occur at a keypad, to be present on an audible device on the exit path. This option allows the exit beeps during arming to be assigned to any of the 8 outputs. The Pulse time (P39E) sets the length of each beep.

## Stay Mode Arm Exit Beeps to Output

**STAY MODE ARM EXIT BEEPS to OUTPUT** - P66E 1-2E (1 = Area A, 2 = Area B)

Option 1 - Output 1      Option 5 - Output 5  
Option 2 - Output 2      Option 6 - Output 6  
Option 3 - Output 3      Option 7 - Output 7  
Option 4 - Output 4      Option 8 - Output 8

Sometimes it can be useful to extend the exit beeps, that occur at a keypad, to be present on an audible device on the exit path. This option allows the exit beeps during the arming of stay mode to be assigned to any of the 8 outputs. The Pulse time (P39E) sets the length of each beep.

## Area Delinquency Delay

**AREA DELINQUENCY DELAY** - P67E 1-2E (1 = Area A, 2 = Area B) (Value 0-99 Days)

Each Area can have their own Delinquency time. The delinquency time monitors the arm/disarms of each Area. If an Area has not been armed within the set number of days a delinquency report will be sent. Each time an Area is armed the delinquency timer is reset. A value of "0" disables the delinquency monitoring.

NOTE: If the default value of "0" is changed at this location (eg a value of 10 is entered meaning 10 days), the next time the area is armed a delinquency restore message will be sent via the dialler (Event type 454) as a test that the function is operating.

## Automatic Arm/Disarm Time Zone

**AUTOMATIC ARM/DISARM TIMEZONE** - P68E 1-2E (1 = Area A, 2 = Area B) (Value 1-8)

Option 1 - Time-Zone 1      Option 5 - Time-Zone 5  
Option 2 - Time-Zone 2      Option 6 - Time-Zone 6  
Option 3 - Time-Zone 3      Option 7 - Time-Zone 7  
Option 4 - Time-Zone 4      Option 8 - Time-Zone 8

If Option 2 or 3 are turned on location P46E then the Area can be automatically armed or disarmed by a time-zone/s. You can assign more than one time-zone to each Area. If assigning multiple time-zones you should insure that they do not overlap as this could cause confusion. A Time-zone would typically be 0830-1700 Monday-Friday. An area will turn on when the Time-zone ends (eg 1700) and turn off when a Time-zone starts (eg 0830)

# Keypads

## Keypad Area Assignment

### KEYPAD AREA ASSIGNMENT - P71E 1-8E

Option 1 - Area "A"

Option 2 - Area "B"

Option 1     **Area "A"** - This option assigns Area A to keypads. If a keypad is assigned to only Area A it can only Arm or Disarm that area.

Option 2     **Area "B"** - This option assigns Area B to keypads. If a keypad is assigned to only Area B it can only Arm or Disarm that area.

## Keypad Button Operations, Misc. Beeps and LED Control

### Keypad Button Operations ( keys options )

#### KEYPAD BUTTON OPTIONS - P72E 1-8E

Option 1 - <CHIME> or <CONTROL><PROGRAM> button Enabled

Option 2 - <BYPASS> button Enabled

Option 3 - <PANIC> button Enabled

Option 4 - Delayed Operation of <PANIC> button

Option 5 - <1> & <3> Panic Alarm Enabled

Option 6 - <4> & <6> Fire Alarm Enabled

Option 7 - <7> & <9> Medical Alarm Enabled

Option 8 - Spare

Option 1     <**CHIME**> - This option enables the <CHIME> button on the Crow LCD keypads. Chime alarms to the keypad buzzer and outputs are disabled when "Chime" is off. If a zone is programmed as a Chime Zone, it can beep the buzzer on a keypad and/or turn on an output as well to give a local "CHIME" indication. A typical use of "Chime" Mode is as a door minder in a shop. Sometimes it may be desirable to disable Chime mode without the need to reprogram the panel. This can be achieved by allowing Chime Mode to be disabled with the <CHIME> button. If you press the <CHIME> button on a Crow LCD keypad for 2 seconds (and this option is turned on for that keypad) the display will show "Chime Mode OFF". This means that the buzzer will now not sound at the keypad concerned and any Chime Mode Outputs will not activate. Performing the process again will toggle chime mode back to the on state again.

Option 2     <**BYPASS**> **button Enabled** - This option enables the <BYPASS> button (by keypad number) on any keypads connected to the panel .

Option 3     <**PANIC**> **button Enabled** - This option enables the <PANIC> button (by keypad number) on the LED keypad connected to the panel .

Option 4     **Delayed Operation of <PANIC> button** - This option assigns a 2 second delay before the <PANIC> button will cause an alarm. The button must be held down for longer than 2 seconds to create a panic alarm.

- Option 5 **<1> & <3> Panic Alarm Enabled** - This option enables a Panic Alarm to be created when buttons <1> & <3> are pressed simultaneously on the LED or keypad. It also enables the <CHIME> & <CONTROL> Panic Alarm when both buttons are pressing simultaneously on a Crow LCD keypad.
- Option 6 **<4> & <6> Fire Alarm Enabled** - This option enables a Fire Alarm to be created when buttons <4> & <6> are pressed simultaneously on the LED keypad. It also enables the <A> & <B> Fire Alarm when both buttons are pressing simultaneously on a Crow LCD keypad.
- Option 7 **<7> & <9> Medical Alarm Enabled** - This option enables a Medical Alarm to be created when buttons <7> & <9> are pressed simultaneously on the LED keypad. It also enables the <B> & <CHIME> Medical Alarm when both buttons are pressing simultaneously on a Crow LCD keypad.
- Option 8 **Spare** -

## Keypad System Beeps & Led Options

### KEYPAD SYSTEM BEEPS & LED OPTIONS - P73E 1-8E

- Option 1 - Mains Fail Beeps Keypad Buzzer
  - Option 2 - Fuse Fail Beeps Keypad Buzzer
  - Option 3 - Battery Low Beeps Keypad Buzzer
  - Option 4 - Telephone Line Fail Beeps Keypad Buzzer
  - Option 5 - System Tamper Beeps Keypad Buzzer
  - Option 6 - Receiver Fail Beeps Keypad Buzzer
  - Option 7 - Turn Off Keypad LED's when Armed
  - Option 8 - Turn Off Keypad LCD & Keypad Backlighting on Mains Fail
- Option 1 **Mains Fail Beeps Keypad Buzzer** - If this option is on a Mains Failure will cause the keypad buzzer to sound continuously. The continuous beep will automatically clear when the Mains returns to normal or it can be silenced by pressing the <ENTER> button on the keypad.
  - Option 2 **Fuse Fail Beeps Keypad Buzzer** - If this option is on a Fuse Failure (12v DC output short) will cause the keypad buzzer to sound continuously. The continuous beep will automatically clear when the short is removed and the fuse returns to normal or it can be silenced by pressing the <ENTER> button on the keypad.
  - Option 3 **Battery Low Beeps Keypad Buzzer** - If this option is on a Panel Battery Low will cause the keypad buzzer to sound continuously. The continuous beep will automatically clear when the battery returns to normal or it can be silenced by pressing the <ENTER> button on the keypad.
  - Option 4 **Telephone Line Fail Beeps Keypad Buzzer** - If this option is on a Telephone Line Failure will cause the keypad buzzer to sound continuously. The continuous beep will automatically clear when the Telephone Line returns to normal or it can be silenced by pressing the <ENTER> button on the keypad.
  - Option 5 **System Tamper Beeps Keypad Buzzer** - If this option is on a Panel Tamper Alarm will cause the keypad buzzer to sound continuously. The Alarm must then be cleared by entering in a valid code at the keypad.
  - Option 6 **Receiver Fail Beeps Keypad Buzzer** - If this option is on a Receiver Failure will cause the keypad buzzer to sound continuously. The continuous beep will automatically clear when the Receiver starts to see transmissions again or it can be silenced by pressing the <ENTER> button on the keypad.
  - Option 7 **Turn Off Keypad LED's when Armed** - This option allows the LED's on a keypad to be turned off when the panel is in the Armed state. It is normally used to cut the illumination from a keypad at night time. The LED's will return to the normal state on disarming of the alarm. The LED's will turn off within 90 seconds of arming the system.
  - Option 8 **Turn Off Keypad LCD & Keypad Backlighting on Mains Fail** - This option allows the backlighting on an LCD on a keypad (both the keypad buttons and the LCD module backlighting) to be turned off when there is a Mains Failure. It is normally used to cut the power consumed by the keypad during a power failure. The LCD backlighting will

turn off within 90 seconds of the mains failing. If a button is pressed at the keypad the backlighting will turn back on again. Following 90 seconds of no keypad activity the backlighting will turn off. The LCD backlighting will return to the normal state when Mains is restored.

## Keypad Arm, Stay, A and B Button Options

### Keypad <Arm> Button Area Assignment

#### *Keypad ARM area*

#### KEYPAD <ARM> BUTTON AREA ASSIGNMENT - P74E 1-8E

Option 1 - Area "A"

Option 2 - Area "B"

Option 1 **Area "A"** - This option assigns the keypad <ARM> button to Area A. If a keypad <ARM> button is assigned to only Area A it can only Arm or Disarm that area.

Option 2 **Area "B"** - This option assigns the keypad <ARM> button to Area B. If a keypad <ARM> button is assigned to only Area B it can only Arm or Disarm that area.

### Keypad <Arm> Button Area Options

#### KEYPAD ARM Access

#### KEYPAD <ARM> BUTTON AREA OPTIONS - P75E 1-8E

Option 1 - <ARM> button can Arm

Option 2 - <ARM> button can Arm Stay Mode

Option 3 - <ARM> button can Disarm at All Times

Option 4 - <ARM> button can Disarm Stay Mode at All Times

Option 5 - <ARM> button can Reset Alarms

Option 6 - <ARM> button can Arm Latchkey Mode

Option 7 - <ARM> button can Disarm During Exit Delay

Option 8 - <ARM> button can Disarm Stay Mode During Exit Delay

Option 1 <ARM> button can Arm - This option enables single button Arming using the <ARM> button. For single button operation to work options 1 & 3 must be off at location P45E.

Option 2 <ARM> button can Arm Stay Mode - This option enables single button Arming of Stay Mode using the <ARM> button. For single button operation to work options 1 & 3 must be off at location P45E.

(NOTE: Following arming of Stay Mode, if the <ENTER> button is pressed, all entry & exit delays will be reset to zero for that armed period).

Option 3 <ARM> button can Disarm at All Times - This option enables single button Disarming using the <ARM> button. For single button disarm operation to work options 1 & 3 must be off at location P45E

Option 4 <ARM> button can Disarm Stay Mode at All Times - This option enables single button Disarming of Stay Mode using the <ARM> button. For single button disarm operation to work options 1 & 3 must be off at location P45E

Option 5 <ARM> button can Reset Alarms - If this option is On, Pressing the <ARM> button (provided Option 3 is also On) will reset an alarm condition without having to enter a user code.

Option 6 <ARM> button can Arm Latchkey Mode - This option enables single button Arming of the alarm in Latchkey report mode using the <ARM> button. For single button disarm operation to work options 1 & 3 must be off at location P45E. When Latchkey Mode is set on Arming, any code without the Latchkey option (P4E Option 6) used to Disarm the Alarm will cause a Disarm report to be sent via the dialler.

- Option 7 <ARM> button can Disarm During Exit Delay - This option allows single button Disarming using the <ARM> button provided the Armed Mode exit delay is active. If the exit delay has expired the <ARM> button cannot be used to disarm the alarm. For single button disarm operation to work options 1 & 3 must be off at location P45E
- Option 8 <ARM> button can Disarm Stay Mode During Exit Delay - This option allows single button Disarming of Stay Mode using the <ARM> button provided the Stay Mode exit delay is active. If the Stay Mode exit delay has expired the <ARM> button cannot be used to disarm Stay Mode. For single button disarm operation to work options 1 & 3 must be off at location P45E

## Keypad <Stay> Button Area Assignment

### *Keypad STAY Areas*

#### KEYPAD <STAY> BUTTON AREA ASSIGNMENT - P76E 1-8E

- Option 1 - Area "A"
- Option 2 - Area "B"
- Option 1 Area "A" - This option assigns the keypad <STAY> button to Area A. If a keypad <STAY> button is assigned to only Area A it can only Arm or Disarm that area.
- Option 1 Area "B" - This option assigns the keypad <STAY> button to Area B. If a keypad <STAY> button is assigned to only Area B it can only Arm or Disarm that area.

## Keypad <Stay> Button Area Options

### *Keypad stay access*

#### KEYPAD <STAY> BUTTON AREA OPTIONS - P77E 1-8E

- Option 1 - <STAY> button can Arm
- Option 2 - <STAY> button can Arm Stay Mode
- Option 3 - <STAY> button can Disarm at All Times
- Option 4 - <STAY> button can Disarm Stay Mode at All Times
- Option 5 - <STAY> button can Reset Alarms
- Option 6 - <STAY> button can Arm Latchkey Mode
- Option 7 - <STAY> button can Disarm During Exit Delay
- Option 8 - <STAY> button can Disarm Stay Mode During Exit Delay
- Option 1 **<STAY> button can Arm** - This option enables single button Arming using the <STAY> button. For single button operation to work options 2 & 3 must be off at location P45E.
- Option 2 **<STAY> button can Arm Stay Mode** - This option enables single button Arming of Stay Mode using the <STAY> button. For single button operation to work options 2 & 3 must be off at location P45E.
- (NOTE: Following arming of Stay Mode, if the <ENTER> button is pressed, all entry & exit delays will be reset to zero for that armed period).**
- Option 3 **<STAY> button can Disarm at All Times** - This option enables single button Disarming using the <STAY> button. For single button disarm operation to work options 2 & 3 must be off at location P45E
- Option 4 **<STAY> button can Disarm Stay Mode at All Times** - This option enables single button Disarming of Stay Mode using the <STAY> button. For single button disarm operation to work options 2 & 3 must be off at location P45E
- Option 5 **<STAY> button can Reset Alarms** - If this option is On, Pressing the <STAY> button (provided Option 3 is also On) will reset an alarm condition without having to enter a user code.
- Option 6 **<STAY> button can Arm Latchkey Mode** - This option enables single button Arming of the alarm in Latchkey report mode using the <STAY> button. For single button disarm operation to work options 2 & 3 must be off at location P45E. When Latchkey Mode is set on Arming, any code without the Latchkey option (P4E Option 6) used to Disarm the Alarm will cause a Disarm report to be sent via the dialler.

- Option 7 **<STAY> button can Disarm During Exit Delay** - This option allows single button Disarming using the <STAY> button provided the Armed Mode exit delay is active. If the exit delay has expired the <STAY> button cannot be used to disarm the alarm. For single button disarm operation to work options 2 & 3 must be off at location P45E
- Option 8 **<STAY> button can Disarm Stay Mode During Exit Delay** - This option allows single button Disarming of Stay Mode using the <STAY> button provided the Stay Mode exit delay is active. If the Stay Mode exit delay has expired the <STAY> button cannot be used to disarm Stay Mode. For single button disarm operation to work options 2 & 3 must be off at location P45E

## Keypad <A> Button Area Assignment

### *Keypad A key Areas*

#### **KEYPAD <A> BUTTON AREA ASSIGNMENT - P78E 1-8E (APPLIES TO CROW LCD KEYPAD ONLY)**

Option 1 - Area "A"

Option 2 - Area "B"

Option 1 **Area "A"** - This option assigns the keypad <A> button to Area A. If a keypad <A> button is assigned to only Area A it can only Arm or Disarm that area.

Option 1 **Area "B"** - This option assigns the keypad <A> button to Area B. If a keypad <A> button is assigned to only Area B it can only Arm or Disarm that area.

## Keypad <A> Button Area Options

### *Keypad A key Options*

#### **KEYPAD <A> BUTTON AREA OPTIONS - P79E 1-8E (APPLIES TO CROW LCD KEYPAD ONLY)**

Option 1 - <A> button can Arm

Option 2 - <A> button can Arm Stay Mode

Option 3 - <A> button can Disarm at All Times

Option 4 - <A> button can Disarm Stay Mode at All Times

Option 5 - <A> button can Reset Alarms

Option 6 - <A> button can Arm Latchkey Mode

Option 7 - <A> button can Disarm During Exit Delay

Option 8 - <A> button can Disarm Stay Mode During Exit Delay

Option 1 **<A> button can Arm** - This option enables single button Arming using the <A> button. For single button operation to work options 2 & 3 must be off at location P45E.

Option 2 **<A> button can Arm Stay Mode** - This option enables single button Arming of Stay Mode using the <A> button. For single button operation to work options 2 & 3 must be off at location P45E.

**(NOTE: Following arming of Stay Mode, if the <ENTER> button is pressed, all entry & exit delays will be reset to zero for that armed period).**

Option 3 **<A> button can Disarm at All Times** - This option enables single button Disarming using the <A> button. For single button disarm operation to work options 2 & 3 must be off at location P45E

Option 4 **<A> button can Disarm Stay Mode at All Times** - This option enables single button Disarming of Stay Mode using the <A> button. For single button disarm operation to work options 2 & 3 must be off at location P45E

Option 5 **<A> button can Reset Alarms** - If this option is On, Pressing the <A> button (provided Option 3 is also On) will reset an alarm condition without having to enter a user code.

Option 6 **<A> button can Arm Latchkey Mode** - This option enables single button Arming of the alarm in Latchkey report mode using the <A> button. For single button Arm operation to work options 2 & 3 must be off at location P45E. When Latchkey Mode is

set on Arming, any code without the Latchkey option (P4E Option 6) used to Disarm the Alarm will cause a Disarm report to be sent via the dialler.

- Option 7 **<A> button can Disarm During Exit Delay** - This option allows single button Disarming using the <A> button provided the Armed Mode exit delay is active. If the exit delay has expired the <A> button cannot be used to disarm the alarm. For single button disarm operation to work options 2 & 3 must be off at location P45E
- Option 8 **<A> button can Disarm Stay Mode During Exit Delay** - This option allows single button Disarming of Stay Mode using the <A> button provided the Stay Mode exit delay is active. If the Stay Mode exit delay has expired the <A> button cannot be used to disarm Stay Mode. For single button disarm operation to work options 2 & 3 must be off at location P45E

## Keypad <B> Button Area Assignment

### *Keypad B Key Areas*

**KEYPAD <B> BUTTON AREA ASSIGNMENT - P80E 1-8E (APPLIES TO CROW LCD KEYPAD ONLY)**

Option 1 - Area "A"

Option 2 - Area "B"

Option 1 **Area "A"** - This option assigns the keypad <B> button to Area A. If a keypad <B> button is assigned to only Area A it can only Arm or Disarm that area.

Option 1 **Area "B"** - This option assigns the keypad <B> button to Area B. If a keypad <B> button is assigned to only Area B it can only Arm or Disarm that area.

## Keypad <B> Button Area Options

### *Keypad B Key Options*

**KEYPAD <B> BUTTON AREA OPTIONS - P81E 1-8E (APPLIES TO CROW LCD KEYPAD ONLY)**

Option 1 - <B> button can Arm

Option 2 - <B> button can Arm STAY Mode

Option 3 - <B> button can Disarm at All Times

Option 4 - <B> button can Disarm Stay Mode at All Times

Option 5 - <B> button can Reset Alarms

Option 6 - <B> button can Arm Latchkey Mode

Option 7 - <B> button can Disarm During Exit Delay

Option 8 - <B> button can Disarm Stay Mode During Exit Delay

Option 1 **<B> button can Arm** - This option enables single button Arming using the <B> button. For single button operation to work options 2 & 3 must be off at location P45E.

Option 2 **<B> button can Arm Stay Mode** - This option enables single button Arming of Stay Mode using the <B> button. For single button operation to work options 2 & 3 must be off at location P45E.

**(NOTE: Following arming of Stay Mode, if the <ENTER> button is pressed, all entry & exit delays will be reset to zero for that armed period).**

Option 3 **<B> button can Disarm at All Times** - This option enables single button Disarming using the <B> button. For single button disarm operation to work options 2 & 3 must be off at location P45E

Option 4 **<B> button can Disarm Stay Mode at All Times** - This option enables single button Disarming of Stay Mode using the <B> button. For single button disarm operation to work options 2 & 3 must be off at location P45E

Option 5 **<B> button can Reset Alarms** - If this option is On, Pressing the <B> button (provided Option 3 is also On) will reset an alarm condition without having to enter a user code.

- Option 6    **<B> button can Arm Latchkey Mode** - This option enables single button Arming of the alarm in Latchkey report mode using the <B> button. For single button Arm operation to work options 2 & 3 must be off at location P45E. When Latchkey Mode is set on Arming, any code without the Latchkey option (P4E Option 6) used to Disarm the Alarm will cause a Disarm report to be sent via the dialler.
- Option 7    **<B> button can Disarm During Exit Delay** - This option allows single button Disarming using the <B> button provided the Armed Mode exit delay is active. If the exit delay has expired the <B> button cannot be used to disarm the alarm. For single button disarm operation to work options 2 & 3 must be off at location P45E
- Option 8    **<B> button can Disarm Stay Mode During Exit Delay** - This option allows single button Disarming of Stay Mode using the <B> button provided the Stay Mode exit delay is active. If the Stay Mode exit delay has expired the <B> button cannot be used to disarm Stay Mode. For single button disarm operation to work options 2 & 3 must be off at location P45E

## Keypad to Output Mask

### KEYPAD to OUTPUT MASK - P82E 1-8E

- Option 1 - Output 1    Option 5 - Output 5  
Option 2 - Output 2    Option 6 - Output 6  
Option 3 - Output 3    Option 7 - Output 7  
Option 4 - Output 4    Option 8 - Output 8

A Keypad can be assigned to an Output or multiple Outputs. If a Keypad is not assigned to an Output a User cannot turn that Output On or Off from the Keypad. This feature is useful when using the access control features of the panel, eg a User may be allowed to operate more than one Output with their code but they will be limited to just the Output assigned to the Keypad they are using.

## <Control> Button to Output Mask

### <CONTROL> BUTTON to OUTPUT MASK - P83E 1-8E

- Option 1 - Output 1    Option 5 - Output 5  
Option 2 - Output 2    Option 6 - Output 6  
Option 3 - Output 3    Option 7 - Output 7  
Option 4 - Output 4    Option 8 - Output 8

The <CONTROL> button at a Keypad can be assigned to an Output or multiple Outputs. If the <CONTROL> button is not assigned to an Output a User cannot access Local Control Mode (by pressing the <CONTROL> button) and turn that Output On or Off from the Keypad. This feature is useful if Outputs are being used to control devices such as lights, etc and you wish to be able to turn them On or Off from a keypad. By limiting the access to Outputs via the <CONTROL> button you can avoid conflict with alarm outputs (eg the User can be denied access to outputs that are being used for alarm functions).

# Keyboard Panic, Fire and Medical Alarms to Outputs and KP Buzzer

## Keypad Panic Alarm to Output

**KEYPAD PANIC ALARM to OUTPUT** - P84E 1-8E (includes <PANIC>, <1> & <3> or <CONTROL> & <CHIME>)

- |                     |                     |
|---------------------|---------------------|
| Option 1 - Output 1 | Option 5 - Output 5 |
| Option 2 - Output 2 | Option 6 - Output 6 |
| Option 3 - Output 3 | Option 7 - Output 7 |
| Option 4 - Output 4 | Option 8 - Output 8 |

A Keypad generated Panic Alarm (either pressing the <PANIC> button, <1> & <3> or <CONTROL> & <CHIME> together) can be assigned to an Output or multiple Outputs. This can be used to operate an audible or visual alarm connected to the Output.

## Keypad Fire Alarm to Output

**KEYPAD FIRE ALARM to OUTPUT** - P85E 1-8E (includes <A> & <B> or <4> & <6>)

- |                     |                     |
|---------------------|---------------------|
| Option 1 - Output 1 | Option 5 - Output 5 |
| Option 2 - Output 2 | Option 6 - Output 6 |
| Option 3 - Output 3 | Option 7 - Output 7 |
| Option 4 - Output 4 | Option 8 - Output 8 |

A Keypad generated Fire Alarm (either pressing the <A> & <B> or <4> & <6> together) can be assigned to an Output or multiple Outputs. This can be used to operate an audible or visual alarm connected to the Output.

## Keypad Medical Alarm to Output

**KEYPAD MEDICAL ALARM to OUTPUT** - P86E 1-8E (includes <B> & <CHIME> or <7> & <9>)

- |                     |                     |
|---------------------|---------------------|
| Option 1 - Output 1 | Option 5 - Output 5 |
| Option 2 - Output 2 | Option 6 - Output 6 |
| Option 3 - Output 3 | Option 7 - Output 7 |
| Option 4 - Output 4 | Option 8 - Output 8 |

A Keypad generated Medical Alarm (either pressing the <B> & <CHIME> or <7> & <9> together) can be assigned to an Output or multiple Outputs. This can be used to operate an audible or visual alarm connected to the Output.

## Keypad Duress Alarm to Output

**KEYPAD DURESS ALARM to OUTPUT** - P87E 1-8E

- |                     |                     |
|---------------------|---------------------|
| Option 1 - Output 1 | Option 5 - Output 5 |
| Option 2 - Output 2 | Option 6 - Output 6 |
| Option 3 - Output 3 | Option 7 - Output 7 |
| Option 4 - Output 4 | Option 8 - Output 8 |

A Keypad generated Duress Alarm (see P25E2E) can be assigned to an Output or multiple Outputs. This can be used to operate an audible or visual alarm connected to the Output. A Duress alarm is created when the alarm is Disarmed with the Duress digit preceding a valid User Code.

## Keypad Tamper Switch Alarm to Output

### KEYPAD TAMPER SWITCH ALARM to OUTPUT - P88E 1-8E

- Option 1 - Output 1      Option 5 - Output 5
- Option 2 - Output 2      Option 6 - Output 6
- Option 3 - Output 3      Option 7 - Output 7
- Option 4 - Output 4      Option 8 - Output 8

If the keypad has a Tamper Switch fitted and this switch is activated, the Tamper Alarm can be assigned to an Output or multiple Outputs. This can be used to operate an audible or visual alarm connected to the Output.

## Keypad Wrong Code Alarm to Output

### KEYPAD WRONG CODE ALARM to OUTPUT - P89E 1-8E

- Option 1 - Output 1      Option 5 - Output 5
- Option 2 - Output 2      Option 6 - Output 6
- Option 3 - Output 3      Option 7 - Output 7
- Option 4 - Output 4      Option 8 - Output 8

If someone is attempting to disarm the alarm by trying various code combinations and they enter in 4 wrong codes the panel will go into a "Wrong Code" tamper alarm. The Alarm can be assigned to an Output or multiple Outputs. This can be used to operate an audible or visual alarm connected to the Output. A correct code entry will reset the tamper alarm.

## Manual Panic Alarm Beeps to Keypad

### MANUAL PANIC ALARM BEEPS TO KEYPAD - P90E 1-8E

- Option 1 - Keypad 1      Option 5 - Keypad 5
- Option 2 - Keypad 2      Option 6 - Keypad 6
- Option 3 - Keypad 3      Option 7 - Keypad 7
- Option 4 - Keypad 4      Option 8 - Keypad 8

When a keypad generated Panic Alarm is generated, the alarm can be silent or it can operate the buzzer in the keypad.

## Manual Fire Alarm Beeps to Keypad

### MANUAL FIRE ALARM BEEPS TO KEYPAD - P91E 1-8E

- Option 1 - Keypad 1      Option 5 - Keypad 5
- Option 2 - Keypad 2      Option 6 - Keypad 6
- Option 3 - Keypad 3      Option 7 - Keypad 7
- Option 4 - Keypad 4      Option 8 - Keypad 8

When a keypad generated Fire Alarm is generated, the alarm can be silent or it can operate the buzzer in the keypad.

## Manual Medical Alarm Beeps to Keypad

### MANUAL MEDICAL ALARM BEEPS TO KEYPAD - P92E 1-8E

- Option 1 - Keypad 1      Option 5 - Keypad 5
- Option 2 - Keypad 2      Option 6 - Keypad 6
- Option 3 - Keypad 3      Option 7 - Keypad 7
- Option 4 - Keypad 4      Option 8 - Keypad 8

When a keypad generated Medical Alarm is generated, the alarm can be silent or it can operate the buzzer in the keypad.

## Wrong Code or Keypad Tamper Beeps To Keypad

### **WRONG CODE or KEYPAD TAMPER SWITCH ALARM BEEPS TO KEYPAD - P93E 1-8E**

- Option 1 - Keypad 1      Option 5 - Keypad 5
- Option 2 - Keypad 2      Option 6 - Keypad 6
- Option 3 - Keypad 3      Option 7 - Keypad 7
- Option 4 - Keypad 4      Option 8 - Keypad 8

If someone enters in an incorrect code more than 4 times or a Keypad Tamper Switch Alarm is generated, the alarm can be silent or it can operate the buzzer in the keypad. The selected keypad, e.g. P93E1E for keypad number 1 is the one at which the alarm has occurred and the options 1-8 are the keypads that will beep in alarm.

## Keypad Chime Timer

### **CHIME ALARM KEYPAD BEEP TIME - P94E 1-8E (Value = 0-255 1/10th Second)**

When a Chime Zone is activated it can operate an Output and/or beep the keypad buzzer. There is a separate Chime timer for each of the 8 keypads. If the value is made "0" for a keypad the Chime Zone will not beep the keypad buzzer. The Keypad Chime Timer can be set to a value from 1-255. The units are in 1/10th second increments. This means that a value of 10 will beep the keypad buzzer for 1 second.

## Proximity Reader Options

### Proximity Reader Led To Output Mapping

#### **PROXIMITY READER LED to OUTPUT MAPPING - P98E 1-8E**

- Option 1 - Proximity Reader 1-8 LED follows Output 1
- Option 2 - Proximity Reader 1-8 LED follows Output 2
- Option 3 - Proximity Reader 1-8 LED follows Output 3
- Option 4 - Proximity Reader 1-8 LED follows Output 4
- Option 5 - Proximity Reader 1-8 LED follows Output 5
- Option 6 - Proximity Reader 1-8 LED follows Output 6
- Option 6 - Proximity Reader 1-8 LED follows Output 7
- Option 7 - Proximity Reader 1-8 LED follows Output 8

If a proximity reader is connected to the control panel it may be desirable to have the LED provide some form of indication such as Arm/Disarm state, etc. By using this location it is possible to link the LED at a reader number to follow the programming of an output. The LED can be used to indicate Arm/Disarm state, Stay Mode Arm/disarm, output On/Off, etc. If chirps have been assigned to access tags/cards (P46E4E) and the output the reader LED is set to follow has the chirps assigned (P50E-P53E), then the output must have a minimum pulse time (P39E) of 10 for it to work correctly.

The proximity reader keypad address number is set at P99E as detailed below.

### Learn Proximity Reader Keypad Address Number

#### **LEARN PROXIMITY READER KEYPAD ADDRESS NUMBER - P99E 1-8E**

(Value = Keypad Address 1-8)

When a Proximity reader is connected to the panel it must have a unique keypad address number assigned so that any program options can be assigned to that specific reader. To program the keypad address you must first connect the reader to the panel via the keypad buss. Then from installer program mode, enter in P99E followed by the keypad address you wish to assign to the reader (eg P99E4E will assign keypad address 4). To assign this keypad

address to a selected reader you have to present a tag or card 5 times within 10 seconds to learn the keypad address number. The tag or card does not have to be enrolled at the panel to set the keypad address. When the address has been learnt by the reader it sends an acknowledgement back to the panel which will stop the learn mode. To assign a different address to another reader you must go through the same process again only this time entering in a different keypad address number (eg P99E5E for keypad address 5). Repeat the process until all readers have been assigned a unique keypad address. Now any keypad specific options can be assigned to the readers (eg assign areas/outputs or users to the reader).

**If you do not assign a unique address to every keypad and reader connected to the keypad buss, a conflict will exist that will cause erratic operation. Each reader or keypad MUST have a different address.**

### NOTE

**The proximity and arming readers flash out the assigned keypad address number on their LED whenever the panel is in “Installer Program” Mode. This allows quick identification of the assigned address for each reader..**

# Key-switches

The two Key-Switch inputs are available on the panel tamper. Normally the panel tamper is a single 2k2 EOL resistor, however if the tamper input is wired as per the type 14 option shown on page 6, the 4k7 resistor becomes Key-switch number 1 and the 8k2 resistor becomes Key-switch number 2 (the 2k2 still acts as the tamper resistor). If the tamper input is shorted out or cut the panel will still go into system tamper alarm but provided the 2k2 resistor is maintained then shorting or opening the 4k7 or 8k2 resistors will operate the key-switch functions.

## Key-Switch Area Assignment

### KEY-SWITCH AREA ASSIGNMENT - P111E 1-2E

(1 = Key-switch # 1, 2 = Key-switch # 2)

Option 1 - Area "A"

Option 2 - Area "B"

Option 1 **Area "A"** - This option assigns the key-switch to Area A. If a key-switch is assigned to only Area A it can only Arm or Disarm that area.

Option 2 **Area "B"** - This option assigns the key-switch to Area B. If a key-switch is assigned to only Area B it can only Arm or Disarm that area.

## Key-Switch Arm/Disarm Options

### KEY-SWITCH ACCESS & OPERATIONAL OPTIONS - P112E 1-2E

(1 = Key-switch # 1, 2 = Key-switch # 2)

Option 1 - Key-Switch can Arm

Option 2 - Key-Switch can Arm Stay Mode

Option 3 - Key-Switch can Disarm

Option 4 - Key-Switch can Disarm Stay Mode

Option 5 - Key-Switch has Security Guard Options

Option 6 - Key-Switch will Arm Latchkey Mode

Option 7 - Key-Switch is NO (Normally Open)

Option 8 - Key-Switch is Momentary

Option 1 **Key-Switch can Arm** - This option enables Arming of the assigned Area via the Key-switch.

Option 2 **Key-Switch can Arm Stay Mode** - This option enables Stay Mode Arming of the assigned Area via the Key-switch.

Option 3 **Key-Switch can Disarm** - This option enables Disarming of the assigned Area via the Key-switch.

Option 4 **Key-Switch can Disarm Stay Mode** - This option enables Stay Mode Disarming of the assigned Area via the Key-switch.

Option 5 **Key-Switch has Security Guard Options** - If the key-switch has option 5 on, they can Arm all Areas assigned, but they may only Disarm if the panel is currently Armed and in the alarm state.

Option 6 **Key-Switch will Arm Latchkey Mode** - If the panel is armed by a key-switch with this option on, then the panel will be armed in Latchkey mode. This means that when the alarm is disarmed by a key-switch with this option off, or a code with option 6 at

P4E off, then a disarm report will be sent. The option is designed to alert the alarm owner when children have returned home and disarmed the alarm.

Option 7 **Key-Switch is NO (Normally Open)** - The key-switch can be a NO (Normally Open) or a NC (Normally Closed) key-switch. The normal, or rest state, of the key-switch can be programmed at this location. If the key-switch contacts usually rest in the open state and close when the key-switch is operated you should turn on option 7.

Option 8 **Key-Switch is Momentary** - The operation of the key-switch can be momentary or latching. If option 8 is on, the key-switch operation is assumed to be momentary. This means that each time the key-switch is operated then released the area will toggle its current state (I.e. if armed it will become disarmed or vice versa). If this option is turned off it is assumed that the key-switch is a latching type. This means that when the key-switch is operated and the key removed the contacts remain in the same state. When a latching key-switch is used, turning on the switch will arm the area and turning it off will disarm the area.

# Zones

## Zone Area Assignment

### ZONE AREA ASSIGNMENT - P121E 1-16E

Option 1 - Area "A"

Option 2 - Area "B"

Option 1 **Area "A"** - This option assigns the Zone to Area A. If a Zone is assigned only to Area A it will activate if Area A is armed. If the zone is in both area A & B then it will activate only when both areas are armed.

Option 2 **Area "B"** - This option assigns the Zone to Area B. If a Zone is assigned only to Area B it will activate if Area B is armed. If the zone is in both area A & B then it will activate only when both areas are armed.

The output day mode timer is how long an output will turn on following a day zone unsealing. The Day Mode Timer is in 1/10th Sec intervals eg 20=2 Seconds.

## Zone Alarm Type Options

### Zone Options A

#### ZONE OPTIONS A - P122E 1-16E

Option 1 - Zone is Active

Option 2 - Zone is N/O

Option 3 - Spare

Option 4 - Keypad Zone

Option 5 - Zone is a Radio Zone

Option 6 - Zone is a Stay Mode Zone

Option 7 - Zone can be Manually Bypassed

Option 8 - Zone can be Auto-Bypassed

Option 1 **Zone is Active** - If this option is on the zone is turned on. If it is turned off the zone will not be monitored by the panel. The panel can provide up to 16 zones but is configured by default as an 8 zone panel with this option turned off for zones 9-16.

Option 2 **Zone is N/O** - This option only applies if the zone input is set to type 14 (zone doubling) at location P125E. When configured as type 14 there are three resistors wired in series on the input, a 2k2 tamper resistor, a 4k7 low zone resistor and an 8k2 high zone resistor. At this point, the zone can be set as having a N/C (Normally closed) alarm contact where the EOL resistor is shorted out in the sealed state or it can be set as a N/O (Normally open) alarm contact where the EOL resistor is in circuit in the sealed state. If this option is turned on it assumes that the alarm contact is N/O.

Option 3 **Spare**

Option 4 **Keypad Zone** - If this option is on the Zone will follow the Input at the corresponding Proximity Reader. If the Proximity Reader is set to Keypad # 1 the input will be either zone 1 or zone 9, eg if P122E1E (zone #1) had option 4 on then the input at reader one will operate zone 1. If P122E9E (zone #9) had option 4 on then the input at

- reader one will operate zone 9. Proximity reader 1 can operate zones 1 or 9 through to proximity reader 8 can operate zones 8 or 16.
- Option 5 **Zone is a Radio Zone** - If this option is on the panel does not scan the hardwired zone input terminal but instead is looking for a radio zone signal. The correct radio type should be set at location P127E to ensure that the radio zone works correctly.
- Option 6 **Zone is a Stay Mode Zone** - If this option is on the zone will be active when Stay Mode is armed. This feature is normally used for arming just part of the alarm at night time.
- Option 7 **Zone can be Manually Bypassed** - If this option is on the zone can be Manually Bypassed at the keypad using the <BYPASS> button. A zone must be Bypassed while in the disarmed state. Once the area with the bypassed zone has been armed then disarmed, the manual bypass is removed and the zone must be manually bypassed again before arming if required. If a zone is configured as a 24 Hour zone (P123E Options 3,4 & 5), they can also Manually Bypassed but in this case the Bypass must be manually removed to re-instate the zone.
- Option 8 **Zone can be Auto-Bypassed** - If this option is on the zone will be Auto-Bypassed if unsealed at the expiry of the exit delay. If a zone is unsealed at the time of arming and remains unsealed when the exit delay expires and this option is on for that zone it will be automatically bypassed by the panel. If the zone seals after that time it will be re-instated automatically and can then cause an alarm. On disarming of the alarm any auto-Bypasses are removed.

## Zone Options B

### ZONE OPTIONS B - P123E 1-16E

- Option 1 - Zone is a Handover Zone
- Option 2 - Zone is a Two Trigger Zone
- Option 3 - Zone is a 24 Hour Zone
- Option 4 - Zone is a 24 Hour Auto-reset Zone
- Option 5 - Zone is a 24 Hour Fire Zone
- Option 6 - Zone is a One-Shot Zone
- Option 7 - Zone is a Chime Zone
- Option 8 - Zone is a Permanent Chime Zone
- Option 1 **Zone is a Handover Zone** - A Handover Zone is one that its entry delay will apply provided a Non-Handover entry zone is triggered first. If no other entry delay zones are triggered before the handover zone the entry delay on that zone does not apply and the alarm will become instant (no entry delay).
- Option 2 **Zone is a Two Trigger Zone** - If this option is on the zone will have to trigger twice within the two trigger time (P25E5E) before it will cause an alarm. If the zone does not trigger a second time before the two trigger time expires, the count is reset and it will take another two triggers to cause an alarm on this zone. If more than one zone is set-up as a two trigger zone, then a single trigger from two separate zones within the two trigger time can also cause an alarm. If the zone becomes faulty and stays in alarm once triggered it will also cause an alarm provided it remains in alarm for longer than the two trigger time.
- Option 3 **Zone is a 24 Hour Zone** - If this option is on the zone will be constantly monitored regardless of the arm/disarm state of the panel. If the 24 Hour zone also has an entry delay programmed (P144E), this delay will apply. If the 24 Hour zone activates but then resets before the entry delay expires no alarm will be generated. This feature can be useful for monitoring plant type alarms such as freezer alarms. Once the alarm has been generated it must be cleared by entry of a valid User code.
- Option 4 **Zone is a 24 Hour Auto-reset Zone** - If this option is on the zone will be constantly monitored regardless of the arm/disarm state of the panel. If the 24 Hour zone also has an entry delay programmed (P144E), this delay will apply. If the 24 Hour zone activates but then resets before the entry delay expires no alarm will be generated. Once an alarm has been generated with a 24 Hour Auto-reset zone, the alarm will be removed automatically once the input reseals.

- Option 5 Zone is a 24 Hour Fire Zone - If this option is on the zone will be constantly monitored regardless of the arm/disarm state of the panel. If the 24 Hour Fire zone also has an entry delay programmed (P144E), this delay will apply. If the 24 Hour Fire zone activates but then resets before the entry delay expires no alarm will be generated. Once the alarm has been generated it must be cleared by entry of a valid User code. The 24 Hour Fire Zone will also cause an alarm output to pulse the alarm to differentiate a fire alarm from a burglar alarm (ie a fire alarm will switch the output on and off at the pulse timer rate whereas a burglar alarm on the same output will sound continuously).
- Option 6 Zone is a One-Shot Zone - If a zone is set as a One-Shot zone it can only trigger the alarm once per armed cycle. If it is not a One-Shot zone it can trigger the alarm multiple times during the armed state. If a value other than "0" is programmed at location P146E the programmed Re-trigger time must expire before the zone can alarm again.
- Option 7 Zone is a Chime Zone - If this option is on, the zone will operate Chime mode when disarmed. When the alarm is armed the Chime Mode is disabled for this zone. A Chime zone can sound the keypad buzzer or operate an output to indicate that the zone is unsealed. It is normally used to monitor areas during the daytime.
- Option 8 Zone is a Permanent Chime Zone - If this option is on, the zone will operate Chime mode when armed or disarmed. When the alarm is armed the zone will continue to only be a Chime Mode Zone and will not cause a burglar alarm. A Chime zone can sound the keypad buzzer or operate an output to indicate that the zone is unsealed.

## Zone Options C

### ZONE OPTIONS C - P124E 1-16E

- Option 1 - Can Arm if Zone is not Ready
- Option 2 - Will Send Multiple Reports to Dialler
- Option 3 - Zone is Monitored for Inactivity
- Option 4 - Zone is on Soak Test
- Option 5 - Zone will report to Area B Account Number
- Option 6 - Zone will Not Report 24 hour Alarms via Dialler
- Option 7 - Spare
- Option 8 - Spare
- Option 1 **Can Arm if Zone is not Ready** - If this option is turned on, plus Options 7 or 8 are on at P45E (cannot Arm if zones not sealed/Ready), this zone can be unsealed and the panel can still be armed. This option allows the panel to still be armed if a low security zone is unsealed yet still stopping arming if a high security zone is unsealed.
- Option 2 **Will Send Multiple Reports to Dialler** - If this option is turned on, a zone will send an alarm report to the monitoring station every time it is activated. If the option is turned off, the zone can only send one alarm report per armed cycle.
- Option 3 **Zone is Monitored for Inactivity** - If this option is on the zone will be checked to see that it operates during the disarmed state. If it is not operated within the time set at P163E a "Sensor-watch" alarm will be generated. This feature is designed to detect a faulty zone that is not operating normally or one that has had it's detection area blocked. If a detector has this option turned on and it doesn't operate when disarmed, the timer at location P163E will start to count down. The timer is stopped when the area assigned to the zone is armed and resumes with the saved value when disarmed again. The timer is reset back to the original value every time the zone operates while disarmed.
- Option 4 **Zone is a Soak Test Zone** - If a zone is suspected of being faulty and is causing false alarms, you can turn it into a Soak Test Zone and it will still be monitored for alarms when armed but it will not cause the sirens to sound or report to the dialler. The Soak Test zone will still be logged in the event memory however so it is possible to check the activity of the zone, via the memory, and after a suitable period of no alarms it can be re-instated as part of the alarm by removing the Soak Test option.
- Option 5 **Zone will report to Area B Account Code** - If a zone is in Areas A & B and it goes into alarm, it will default to reporting on the Area A Account Code (see P62E). By

turning this option on when a zone is in both areas it will report to Area B account Code.

- Option 6 **Zone will Not Report 24 Hour Alarms via Dialler** - If this option is turned on and the zone is set as a 24 Hour type, when an alarm is generated, the alarm will not be transmitted to the monitoring station via the dialler.

## Zone EOL (End-Of-Line) Options and Vibration Settings

There are 8 hardwired zone inputs on the panel. Each of these inputs can have different EOL (End-of-Line) configurations if desired. The input can be a short circuit wire loop (Type 0), one of 11 different single resistor values (Types 1-11), can provide 8 zones with tamper (Types 12,13), zone doubling to allow for up to 16 zones plus tamper (Type 14), or zone doubling without tamper (Type 15). See Zone Inputs on page9 for the resistor combinations and colour codes.

### Zone EOL (End-Of-Line) Options - P125E 1-8E

- |                               |                               |
|-------------------------------|-------------------------------|
| Option 0 - Short Circuit Loop | Option 8 - 6k8                |
| Option 1 - 1k                 | Option 9 - 10k                |
| Option 2 - 1k5                | Option 10 - 12k               |
| Option 3 - 2k2                | Option 11 - 22k               |
| Option 4 - 3k3                | Option 12 - 2k2 // 4k7        |
| Option 5 - 3k9                | Option 13 - 3k3 // 6k8        |
| Option 6 - 4k7                | Option 14 - 2k2 // 4k7 // 8k2 |
| Option 7 - 5k6                | Option 15 - 4k7 // 8k2        |

### Zone Response Time

There are 8 hardwired zone inputs on the panel. The response time (how quickly the input responds to an input trigger) can be varied for each zone. The first 8 settings are very fast response times normally used when vibration sensors are connected to a zone input. Response Settings 1-8 (vibration) can only be applied to zones 1-8 and the zone EOL setting (P125E) must be set to type 3 (2k2). Zone doubling is not available when vibration settings are used.

The response settings 9-26 start at about 200 ms for setting 9 through to 1.05 sec for setting 26. If zone doubling is turned on, both zones on an input will have the same response time (zones 1 & 9 would have the same time).

### ZONE RESPONSE TIME - P126E 1-8E

- Response Setting 1 - Highest Vibration setting
- Response Setting 2 - Middle Vibration setting
- Response Setting 3 - Middle Vibration setting
- Response Setting 4 - Middle Vibration setting
- Response Setting 5 - Middle Vibration setting
- Response Setting 6 - Middle Vibration setting
- Response Setting 7 - Middle Vibration setting
- Response Setting 8 - Lowest Vibration setting
- Response Setting 9 - 200 ms
- Response Setting 10 - 250 ms
- Response Setting 11 - 300 ms
- Response Setting 12 - 350 ms
- Response Setting 13 - 400 ms

Response Setting 14 - 450 ms  
Response Setting 15 - 500 ms  
Response Setting 16 - 550 ms  
Response Setting 17 - 600 ms  
Response Setting 18 - 650 ms  
Response Setting 19 - 700 ms  
Response Setting 20 - 750 ms  
Response Setting 21 - 800 ms  
Response Setting 22 - 850 ms  
Response Setting 23 - 900 ms  
Response Setting 24 - 950 ms  
Response Setting 25 - 1000 ms  
Response Setting 26 - 1050 ms

## Radio Zone Detector Type

Any of the 16 zones can be made radio zones. There are multiple types of radio detectors that can be used on the panel. It is important to set the correct radio type for the detector being used so that all of the special functions such as battery low signals, tamper alarms, reed switch open/close signals and supervision signals can all be monitored correctly.

### RADIO ZONE DETECTOR TYPE - P127E 1-16E

Radio Type 0 - Generic  
Radio Type 1 - Crow Merlin PIR (supervised signal ignored)  
Radio Type 2 - Crow Merlin PIR (supervised signal active)  
Radio Type 3 - Fremlink with checksum (supervised signal active)  
Radio Type 4 - Fremlink with checksum (Non-supervised)  
Radio Type 5 - Crow AE series battery Low  
Radio Type 6 - Crow AE series Radio Reed Switch  
Radio Type 11 - Ness Radio devices Battery Low  
Radio Type 12 - Ness Radio Reed Switch  
Radio Type 21 - Electronics Line Cougar Radio PIR  
Radio Type 31 - Visonic K900 Radio PIR  
Radio Type 32 - Visonic Powercode (supervised signal ignored)  
Radio Type 33 - Visonic Powercode (supervised signal active)  
Radio Type 34 - Siemens (supervised signal ignored)  
Radio Type 35 - Siemens (supervised signal active)

Type 0 **Generic** - If you wish to use a detector that is not on the above list then set the type a "0" and the panel will still respond to the radio detector every time the learnt code is received.

Type 1 **Crow Merlin PIR (unsupervised)** - If a Crow Merlin radio PIR is used on the panel select Type 1 so the panel correctly recognizes the alarm, tamper & battery low signal from the device. The automatic supervised signal sent every 40 minutes by the PIR is ignored in this mode.

Type 2 **Crow Merlin PIR (supervised)** - If a Crow Merlin radio PIR is used selecting Type 2 will allow the panel to correctly recognize the alarm, tamper & battery low signal from the device. Selecting this option also starts the supervise timer (P25E4E). The supervise timer is constantly being reset while valid supervisory signals are being received from the detector. If no supervise signals are received from the PIR within the supervise timer value a supervised alarm is generated.

- Type 3 **Freelink with checksum (supervised signal active)** - If a Crow Freelink radio PIR is used selecting Type 3 will allow the panel to correctly recognize the alarm, tamper & battery low signal from the device. Selecting this option also starts the supervise timer (P25E4E). The supervise timer is constantly being reset while valid supervisory signals are being received from the detector. If no supervise signals are received from the PIR within the supervise timer value a supervised alarm is generated.
- Type 4 **Freelink with checksum (non-supervised)** - If a Crow Freelink radio PIR is used selecting Type 4 will allow the panel to correctly recognize the alarm, tamper & battery low signal from the device. The automatic supervisory signal sent by the PIR is ignored in this mode.
- Type 5 **Crow AE Series Battery Low** - If a Crow (AE) radio pendant or PIR is used on the panel selecting Type 5 allows the panel to correctly recognize the battery low and tamper signals from Crow (AE) devices.
- Type 6 **Crow AE Series Radio Reed Switch** - If a Crow (AE) radio reed switch is used on the panel selecting Type 6 allows the panel to correctly recognize the open and closed signals from the reed switch so the zone LED can follow the correct state of the reed switch (ie open or closed). It also recognizes the battery low signal from the Crow (AE) device.
- Type 11 **Ness Battery Low** - If a Ness radio pendant or PIR is used on the panel selecting Type 11 allows the panel to correctly recognize the battery low and tamper signals from Ness devices.
- Type 12 **Ness Radio Reed Switch** - If a Ness radio reed switch is used on the panel selecting Type 12 allows the panel to correctly recognize the battery low and tamper signals from the Ness device. It also recognizes the open and closed signals from the reed switch so the zone LED can follow the correct state of the reed switch (ie open or closed)
- Option 21 **Electronics Line Radio PIR** - If an Electronics Line radio PIR (Cougar) is used on the panel selecting Type 21 allows the panel to correctly recognize the alarm, tamper & battery low signal from this device.
- Option 31 **Visonic Radio PIR** - If a Visonic K900 radio PIR is used on the panel selecting Type 31 allows the panel to correctly recognize the alarm, tamper & battery low signal from this device.
- Option 32 **Visonic Powercode (unsupervised)** - If a Visonic Powercode radio device is used on the panel selecting Type 32 allows the panel to correctly recognize the alarm, tamper and battery low signal from the device. The supervisory signal sent by the device is ignored in this mode.
- Option 33 **Visonic Powercode (supervised)** - If the Visonic Powercode range of radio PIR or reed switch are used on the panel selecting Type 33 allows the panel to correctly recognize the alarm, tamper & battery low signals from the devices as well as the open/close signal from the reed switch. Selecting this option also starts the supervise timer (P25E4E). The supervise timer is constantly being reset while valid supervisory signals are being received from the detector. If no supervise signals are received from the PIR within the supervise timer value a supervised alarm is generated.
- Option 34 **Siemens (unsupervised)** - If a Siemens radio device is used on the panel selecting Type 34 allows the panel to correctly recognize the alarm, tamper and battery low signal from the device. The supervisory signal sent by the device is ignored in this mode.
- Option 35 **Siemens (supervised)** - If the Siemens radio PIR is used on the panel selecting Type 34 allows the panel to correctly recognize the alarm, tamper & battery low signals from the device. Selecting this option also starts the supervise timer (P25E4E). The supervise timer is constantly being reset while valid supervisory signals are being received from the detector. If no supervise signals are received from the PIR within the supervise timer value a supervised alarm is generated.

# Zone Alarms to Output and Keyboard Buzzer Mapping

## Armed Zone Alarms to Output

### **ARMED ZONE ALARMS to OUTPUT - P128E 1-16E**

- |                     |                     |
|---------------------|---------------------|
| Option 1 - Output 1 | Option 5 - Output 5 |
| Option 2 - Output 2 | Option 6 - Output 6 |
| Option 3 - Output 3 | Option 7 - Output 7 |
| Option 4 - Output 4 | Option 8 - Output 8 |

If an Area is Armed and a zone assigned to that Area activates, the zone can trigger selected Outputs for local alarm signalling. This location assigns Zones to Outputs for alarms that occur when in the Full Armed State.

## Stay Mode Zone Alarms to Output

### STAY MODE ZONE ALARMS to OUTPUT - P129E 1-16E

- Option 1 - Output 1      Option 5 - Output 5
- Option 2 - Output 2      Option 6 - Output 6
- Option 3 - Output 3      Option 7 - Output 7
- Option 4 - Output 4      Option 8 - Output 8

If an Area has Stay Mode Armed and a zone assigned to that Area activates, the zone can trigger selected Outputs for local alarm signalling. This location assigns Zones to Outputs for alarms that occur when Stay Mode is Armed.

## 24 Hour Zone Alarms to Output

### 24 HOUR ZONE ALARMS to OUTPUT - P130E 1-16E

- Option 1 - Output 1      Option 5 - Output 5
- Option 2 - Output 2      Option 6 - Output 6
- Option 3 - Output 3      Option 7 - Output 7
- Option 4 - Output 4      Option 8 - Output 8

If a zone is programmed as a 24 Hour type and it activates, the zone can trigger selected Outputs for local alarm signalling. If the zone is a standard 24 hour type (P123E3E) the output will turn for the full reset time, if it is an Auto-reset type (P123E4E) the output will either turn off when the reset time expires or if the input clears and if it is a Fire type (P123E5E) the output will pulse at a rate equal to the pulse time for that output.

## Chime Zone Alarms to Output

### CHIME ZONE ALARMS to OUTPUT - P131E 1-16E

- Option 1 - Output 1      Option 5 - Output 5
- Option 2 - Output 2      Option 6 - Output 6
- Option 3 - Output 3      Option 7 - Output 7
- Option 4 - Output 4      Option 8 - Output 8

If a zone is programmed as a Chime zone (P123E7E) and it activates, the zone can trigger selected Outputs for local alarm signalling. The output will operate for the Chime to Output time at location P41E. The zone must clear before the output can be activated again.

## Zone Tamper Alarms to Output

### ZONE TAMPER ALARMS to OUTPUT - P132E 1-16E

- Option 1 - Output 1      Option 5 - Output 5
- Option 2 - Output 2      Option 6 - Output 6
- Option 3 - Output 3      Option 7 - Output 7
- Option 4 - Output 4      Option 8 - Output 8

If a hardwired zone is programmed to allow tamper monitoring (P125E types 12,13 & 14), or the zone is a radio detector with tamper, the zone tamper can trigger selected Outputs for local alarm signalling.

## Armed Zone Alarm Beeps to Keypad

### ARMED ZONE ALARM BEEPS TO KEYPAD - P134E 1-16E

- Option 1 - Keypad 1    Option 5 - Keypad 5
- Option 2 - Keypad 2    Option 6 - Keypad 6
- Option 3 - Keypad 3    Option 7 - Keypad 7
- Option 4 - Keypad 4    Option 8 - Keypad 8

If an Area is Armed and a zone assigned to that Area activates, the zone can sound the buzzer at selected keypads for local alarm signalling. This location assigns zone alarm beep to a keypad for alarms that occur when in the Full Armed State.

## Stay Mode Zone Alarm Beeps to Keypad

### STAY MODE ZONE ALARM BEEPS TO KEYPAD - P135E 1-16E

- Option 1 - Keypad 1    Option 5 - Keypad 5
- Option 2 - Keypad 2    Option 6 - Keypad 6
- Option 3 - Keypad 3    Option 7 - Keypad 7
- Option 4 - Keypad 4    Option 8 - Keypad 8

If an Area is Stay Mode Armed and a zone assigned to that Area activates, the zone can sound the buzzer at selected keypads for local alarm signalling. This location assigns zone alarm beep to a keypad for alarms that occur when in Stay Mode is Armed.

## 24 Hour Zone Alarm Beeps to Keypad

### 24 HOUR ZONE ALARM BEEPS TO KEYPAD - P136E 1-16E

- Option 1 - Keypad 1    Option 5 - Keypad 5
- Option 2 - Keypad 2    Option 6 - Keypad 6
- Option 3 - Keypad 3    Option 7 - Keypad 7
- Option 4 - Keypad 4    Option 8 - Keypad 8

If a zone is programmed as a 24 Hour type and it activates, the zone can sound the buzzer at selected keypads for local alarm signalling. If the zone is a standard 24 hour type (P123E3E) or Fire type (P1235E) the keypad buzzer will sound until reset by a User but if it is an Auto-reset type (P123E4E) the keypad buzzer will reset when the input clears.

## Chime Zone Alarm Beeps to Keypad

### CHIME ZONE ALARM BEEPS TO KEYPAD - P137E 1-16E

- Option 1 - Keypad 1    Option 5 - Keypad 5
- Option 2 - Keypad 2    Option 6 - Keypad 6
- Option 3 - Keypad 3    Option 7 - Keypad 7
- Option 4 - Keypad 4    Option 8 - Keypad 8

If a zone is programmed as a Chime zone and it activates, the zone can sound the buzzer at selected keypads for local alarm signalling. The duration of the Chime beep is programmed at location P94E. The Chime function can also be locally disabled at each keypad individually if not required (see Page 46 for details).

## Zone Tamper Alarm Beeps to Keypad

### **ZONE TAMPER ALARM BEEPS TO KEYPAD - P139E 1-16E**

- Option 1 - Keypad 1      Option 5 - Keypad 5
- Option 2 - Keypad 2      Option 6 - Keypad 6
- Option 3 - Keypad 3      Option 7 - Keypad 7
- Option 4 - Keypad 4      Option 8 - Keypad 8

If a hardwired zone is programmed to allow tamper monitoring (P125E types 12, 13 & 14), or the zone is a radio detector with tamper, the zone tamper can beep the keypad buzzer at individual keypads.

## Radio Supervise Fail Beeps to Keypad

### **RADIO SUPERVISE FAIL BEEPS TO KEYPAD - P140E 1-16E**

- Option 1 - Keypad 1      Option 5 - Keypad 5
- Option 2 - Keypad 2      Option 6 - Keypad 6
- Option 3 - Keypad 3      Option 7 - Keypad 7
- Option 4 - Keypad 4      Option 8 - Keypad 8

If a zone is programmed as a radio zone and that type is actively monitoring the supervision signal, a supervise signal failure from the detector alarm can sound the buzzer at selected Keypads for local alarm signalling.

## Zone Inactivity Alarm Beeps to Keypad

### **ZONE INACTIVITY ALARM BEEPS TO KEYPAD - P141E 1-16E**

- Option 1 - Keypad 1      Option 5 - Keypad 5
- Option 2 - Keypad 2      Option 6 - Keypad 6
- Option 3 - Keypad 3      Option 7 - Keypad 7
- Option 4 - Keypad 4      Option 8 - Keypad 8

If the zone is programmed for inactivity monitoring (P124E3E) and it is not operated within the time set at P163E a "Sensor-watch" alarm will be generated. A "Sensor-watch" failure from the detector can sound the buzzer at selected Keypads for local alarm signalling.

## Armed Zone Entry Delay Beeps to Keypad

### **ARMED ZONE ENTRY DELAY BEEPS TO KEYPAD - P142E 1-16E**

- Option 1 - Keypad 1      Option 5 - Keypad 5
- Option 2 - Keypad 2      Option 6 - Keypad 6
- Option 3 - Keypad 3      Option 7 - Keypad 7
- Option 4 - Keypad 4      Option 8 - Keypad 8

If the alarm is Armed and a delay zone triggers the entry delay it can also beep the keypad buzzer to warn that the entry delay is counting down and the alarm should be turned off.

## Stay Mode Entry Delay Beeps to Keypad

### **STAY MODE ENTRY DELAY BEEPS TO KEYPAD - P143E 1-16E**

- Option 1 - Keypad 1      Option 5 - Keypad 5
- Option 2 - Keypad 2      Option 6 - Keypad 6
- Option 3 - Keypad 3      Option 7 - Keypad 7
- Option 4 - Keypad 4      Option 8 - Keypad 8

If Stay Mode is Armed and a Stay Mode delay zone triggers the entry delay it can also beep the keypad buzzer to warn that the entry delay is counting down and the alarm should be turned off.

## Armed Zone Entry Delay Time

**ARMED ZONE ENTRY DELAY TIME** - P144E 1-16E (Value 0-9999 Seconds)

Each Zone has it's own Entry Delay time when in the Full Armed State. The delay can be programmed from 0-9999 seconds in one second increments. If the entry delay is set to "0" the zone will be an instant zone.

## Stay Mode Zone Entry Delay Time

**STAY MODE ZONE ENTRY DELAY TIME** - P145E 1-16E (Value 0-9999 Seconds)

Each Zone has it's own Entry Delay time when in Stay Mode. The delay can be programmed from 0-9999 seconds in one second increments. If the entry delay is set to "0" the zone will be an instant zone.

## Zone Re-Trigger Time ( lockout time )

**ZONE RE-TRIGGER TIME** - P146E 1-16E (Value 0-255 Minutes)

Each Zone has it's own alarm Re-trigger Time. The delay can be programmed from 0-255 minutes. Once a zone has activated it cannot be activated again until the Re-trigger Time has expired.

## Zone CID Report Codes

### Zone Alarm Contact ID Report Code

**ZONE ALARM CONTACT ID REPORT CODE** - P157E 1-16E (3 digit event code)

Normally a zone alarm would default to reporting a standard "Burglar Alarm" code of "130" when the zone activates. If the zone is not being used as a burglar alarm and you need to identify the correct type of alarm event you can change the event code at this location (eg if zone 5 was a fire sensor you could program a value of "110" at P157E5E).

### Zone Near Alarm Contact ID Report Code

**ZONE NEAR ALARM CONTACT ID REPORT CODE** - P158E 1-16E (3 digit event code)

If the Near & Confirmed zone alarm reporting option was active the default report code for a "Near Alarm" is "138" when the zone activates for the first time. There should be no reason to change this code but if some special application was to be used it can be changed at this location.

### Zone Confirmed Alarm Contact ID Report Code

**ZONE CONFIRMED ALARM CONTACT ID REPORT CODE** - P159E 1-16E  
(3 digit event code)

If the Near & Confirmed zone alarm reporting option was active the default report code for a "Confirmed Alarm" is "139" when a second zone activates within 60 minutes of the near alarm. There should be no reason to change this code but if some special application was to be used it can be changed at this location.

## Zone Alarm Voice Message Number

**ZONE ALARM VOICE MESSAGE NUMBER** - P160E 1-16E (Value 0-99)

If the Optional Voice Board is fitted and the alarms are to be reported in Voice Format, each zone can be assigned a voice message to report the alarm type. If this location is set to "0" the zone will not report via the dialler. If Option 1 at P46E is turned on (use near and confirmed alarm reporting) the panel will not send an alarm in this format.

## Armed and Stay Mode Entry Delay Times

### Armed Entry Delay to Output

#### *Zone Entry OP/Away*

**ARMED ENTRY DELAY BEEPS to OUTPUT** - P161E 1-16E

- Option 1 - Output 1
- Option 2 - Output 2
- Option 3 - Output 3
- Option 4 - Output 4
- Option 5 - Output 5
- Option 6 - Output 6
- Option 7 - Output 7
- Option 8 - Output 8

If the alarm is Armed and a delay zone triggers the entry delay it can also beep an Output to warn that the entry delay is counting down and the alarm should be turned off.

### Stay Mode Entry Delay to Output

#### *Zone Entry OP/Stay*

**STAY MODE ENTRY DELAY to OUTPUT** - P162E 1-16E

- |                     |                     |
|---------------------|---------------------|
| Option 1 - Output 1 | Option 5 - Output 5 |
| Option 2 - Output 2 | Option 6 - Output 6 |
| Option 3 - Output 3 | Option 7 - Output 7 |
| Option 4 - Output 4 | Option 8 - Output 8 |

If Stay Mode is Armed and a delay zone triggers the entry delay it can also beep an Output to warn that the entry delay is counting down and the alarm should be turned off.

## Zone Watch Dog Timer

### Zone inactivity timer

**SENSOR\_WATCH TIME** - P163E 1-16E (Value 0-9999 Minutes)

If the zone is programmed as a "Sensor-Watch" zone (P124E3E) and it is not operated within the time set at this location a "Sensor-watch" alarm will be generated. If a detector has this option turned on and it doesn't operate when disarmed, this timer will start to count down for the zone/s concerned. The timer is stopped when the area assigned to the zone/s is armed and resumes with the saved value when disarmed again. The timer is reset back to the original value every time the zone operates while disarmed.

## Learn/Find and Delete Radio Zone Codes

### Learn Radio Zone Codes

#### **LEARN RADIO ZONE CODES - P164E 1-16E**

A RADIO Zone must be enrolled into the panel before it can be used.

To learn a Radio Zone you must first have a compatible receiver connected to the panel keypad buss. With the receiver connected and the panel in program mode, entering P164E then the zone number you wish to enrol, eg 5E for zone 5, the keypad will start to beep to indicate that learn mode has been started and the LED on the receiver will flash. Now operate the detector you wish to learn into Zone 5 slot. Once the transmitted code has been received by the panel and saved, the keypad will stop beeping and the LED on the receiver will stop flashing.

When learning a new radio zone the panel checks all possible locations (including pendants) before saving the new code to ensure that the code has not already been loaded into another slot. If the code already exists, the keypad will indicate which slot the code is already installed at. A number from 1-16 indicates a zone slot and a number from 21-100 indicates a user slot.

### Delete a Radio Zone Code

#### **DELETE a RADIO ZONE CODE - P165E 1-16E**

If you wish to delete a single Radio Zone, pressing P165E then the Zone number while in Program Mode will delete the stored code against that Zone, eg P165E 5E will remove the code stored for Zone 5.

### Find a Zone Location

#### **FIND a RADIO ZONE LOCATION - P166E 0E**

If you have a Radio detector loaded into the panel but are unsure which location (Zone #), pressing P166E then 0E while in Program Mode on an LED Keypad will start "Find" Mode. There is no need to press 0E when using an LCD keypad because the keypad will give you written prompts after entering P166E. The keypad will start to beep to indicate that "Find" mode has been started and the LED on the Receiver will flash. Now operate the Radio Detector you wish to find. If the Radio Detector is in memory the keypad will display the number (1-16 indicates a zone, and 21-100 indicates a user). The keypad will stop beeping and the LED on the Receiver will stop flashing.

# Time Zones

## Holidays

### **HOLIDAYS** - P170E 1-8E (DDMMYY)

It is possible to pre-program up to 8 holidays. Holidays can override the time-zone function on the programmed day. For example, if an output was automatically controlled by a time-zone, the pre-programmed holidays can stop the output from turning on or off on a holiday. A holiday consists of a single day programmed by Date/Month/Year (DDMMYY). The holiday begins at the start of the day (00:00:00) and finishes immediately before midnight (23:59:59) on the programmed date. Holidays can be programmed in any order (although for simplicity it is recommended that they are programmed in chronological order) and the panel automatically removes them once the day ends. If you wish to manually remove a programmed holiday you must program in 000000 at the holiday location. If the holiday date you are attempting to enter is older than the current date the panel will not save the data eg if the current date was 111204 (11th of December 2004) and you tried to enter in 101204 (10th of December 2004) the panel will not save the programmed holiday as the day has already elapsed.

## Time Zone Days

### **TIMEZONE DAYS** - P171E 1-8E

- Option 1 - Sunday
- Option 2 - Monday
- Option 3 - Tuesday
- Option 4 - Wednesday
- Option 5 - Thursday
- Option 6 - Friday
- Option 7 - Saturday
- Option 8 - Invert

The Time-zone days are the days that the time-zone will be active. You can select any combination of the days, eg days 2,3,4,5,6 for Monday to Friday or 1&7 for Saturday & Sunday, etc. The invert function selects all times outside those selected. There are 8 Time-zones that can be programmed.

## Time Zone Start and Stop Times

### Time Zone Start Time

**TIMEZONE START TIME** - P172E 1-8E (HHMM)

The Time-zone start time is when the time-zone begins. It would normally be set to the beginning of the day, E.g. if you were automatically arming and disarming an area with a time-zone and you wanted it to disarm when the time-zone started you would set the start time to about 0830. The start time is programmed in 24 hour format (eg 0000-2359).

If you are setting up the time-zone during the active period (eg if the time-zone goes from 0830-1700 and the current time is 1200) you will have to wait until the next minute expires before the panel will update the time-zone status. You can see if the time-zone is active at location P200E4E.

### Time Zone End Time

**TIMEZONE END TIME** - P173E 1-8E (HHMM)

The Time-zone end time is when the time-zone finishes. It would normally be set to the end of the day, eg if you were automatically arming and disarming an area with a time-zone and you wanted it to arm when the time-zone ended you would set the end time to about 1700. The Time-zone end is active at the end of the programmed minute eg if the time-zone end time was set to 1700, the actual time that the time-zone operates will be at 17:01. The end time is programmed in 24 hour format (eg 0000-2359)

### Time Zone Options

**TIMEZONE OPTIONS** - P174E 1-8E

1 = Ignore Holidays

2-8 = Spare

If option 1 is turned on for a Time-zone, that time-zone will not be disabled when a holiday occurs. Normally when a holiday occurs all Time-zones will be disabled but if this option is turned on the Time-zone will not be affected when a holiday is active.

# Dialler

## Dialler Options

### DIALLER OPTIONS - P175E 1E

Option 1 - Dialler is Enabled

Option 2 - Fax Defeat

Option 3 - Disable Telephone Line Monitoring

Option 4 - Pulse Dialling (NOTE: For DTMF 4 & 5 must be OFF)

Option 5 - Reverse Pulse Dialling (NOTE: For DTMF 4 & 5 must be OFF)

Option 6 - Long DTMF Dialling Digits

Option 7 - Auto-detect Modem

Option 8 - Force V21 Mode

- Option 1     **Dialler is Enabled** - If this option is turned off the dialler will be disabled. The option must be on to allow the dialler to make calls.
- Option 2     **Fax Defeat** - The panel can automatically answer an in-coming call in two ways. The first is to set the auto-answer ring count to a convenient number (P175E4E) and let the phone ring until this number is reached at which time the panel will answer the call. The second method is to use fax defeat which entails calling the panel and letting it ring no more than 4 times, hanging up, then ringing back within 45 seconds. The panel will now answer the call on the first ring. There is also a manual answer function described on page 46.
- Option 3     **Disable Telephone line Monitoring** - If the panel is connected to a poor telephone line and the line failure alarm is appearing regularly, by turning this option on the panel will not do the line test.
- Option 4     **Pulse Dial** - If this option is Off the panel will dial in DTMF format, if On then the panel will dial using Pulse Dialling format
- Option 5     **Reverse Pulse Dial** - If this option is On, and option 4 is On, then the panel will dial using Reverse Pulse Dialling format (eg the number 9 = 1 pulse). If this option is Off and Option 4 is On, the panel will dial in normal Pulse format (eg the number 9 = 9 pulses).
- Option 6     **Long DTMF Dialling Digits** - If this option is Off, the panel will dial using normal dialling (75ms on & 75ms off). If it is On, the panel will dial using the long tones (100ms on & 100ms off).
- Option 7     **Auto-detect Modem** - If this option is on the panel will answer an in-coming call with the V21 acknowledge tone. If the modem does not respond within 5 seconds the panel will then generate the acknowledge tones for BELL103 format. It will repeat this cycle twice and then hang-up if no communication with a modem is established.
- Option 8     **Force V21 Mode** - The dial up panel to PC link can be established using either Bell 103 or V21. If the auto-detect function at option 7 does not result in the best format for your modem then you can force the panel to only communicate in one format. If the LED is off the format is BELL103, LED on means V21.

## Dialler Options B

### DIALLER OPTIONS B - P175E 2E

Option 1 - Step to next Number

Option 2 - Upload/download uses Call-back Number

Option 3 - Upload/download only if Disarmed

Option 4 - Send Test Calls Only if Armed

Option 5 - Spare

Option 6 - Hold line open following Domestic/Voice report for DTMF control

Option 7 - First to Open Last to Close Reporting

Option 8 - Spare

Option 1 **Step to next Number** - If more than one telephone number is programmed, this option will force the dialler to step through each number after a call. If this option is off the dialler will make all calls to the first number before moving on to the next number.

Option 2 **Upload/download uses Call-back Number** - A Telephone number can be programmed as a Call-back number. If this option is turned on, and a PC contacts the panel a direct connection cannot be made with the PC. The panel will hang-up the call and dial the PC back on the Call-back number.

Option 3 **Upload/download only if Disarmed** - If this option is turned on, and a PC attempts to contact the panel while the alarm is Armed a direct connection cannot be made as the panel will not answer the call. If the panel is Disarmed a connection can be established.

Option 4 **Send Test Calls Only if Armed** - If this option is On the panel will only send a daily test call if it is Armed. This option assumes that the normal arm/disarm signals sent on a daily basis can serve as a test and that the connection only needs to be verified daily if the panel is left in the armed state for periods longer than 24 hours.

Option 5 **Spare**

Option 6 **Hold line open following Domestic/Voice report for DTMF control** - If this option is On the dialler will keep the telephone line open after being kissed-off following a Domestic or Voice alarm call so that the person at the phone can then use their DTMF codes to arm/disarm the system or turn on the optional microphone if required.

Option 7 **First to Open Last to Close Reporting** - If this option is on and the alarm is split into two Areas, then the "Arm" report to the monitoring station will only be sent when both areas are armed and it will be a single report on Area A account code (last to close). On Disarming of the alarm the disarm report will be sent when either Area is disarmed (first to open). Only one disarm report will be sent using the Area A account code. If zones in both areas are bypassed, the bypass report for all zones will only be sent when both areas are armed (last to close) but the Bypass restore reports will be sent only when the Area associated with the zone is disarmed. In this way if an area remains armed and it's associated bypassed zone/s are still bypassed the monitoring station knows that the bypasses have not been removed yet.

## Auto Answer Ring count

### AUTO-ANSWER RING COUNT - P175E 3E (Value 0-99)

If the dialler is set to answer an in-coming call for remote control or upload/download the number of rings before answering the call can be set at this location. There is also a manual answer function described on page 46.

## Test Call options

### TIME to the FIRST DIALLER TEST CALL

#### *Test Resync HHMM*

**TIME to the FIRST DIALLER TEST CALL** - P175E 4E (Value 0000-2359)

If the dialler is set to send Automatic Test Calls, the start time for the first call is set at this location. This allows the test call to be linked to a quiet period where the line would not normally be used (eg 2300)

### Test Call Time Period

**TEST CALL TIME PERIOD** - P175E 5E (Value 0-255 Hours)

When reporting in Contact ID format the panel can send regular test calls to the monitoring company to check the integrity of the panel and the line. The regularity of the test calls is set at this location. It would normally be set to a value of 24 so that a test call is sent once a day. The start time for the first test should also be set at location P175E4E.

## Keypad Listen-In and Output Options

### Keypad Listen-In Options

**KEYPAD LISTEN-IN OPTIONS** - P175E 6E

- Option 1 - Listen-in Enabled when dialling only and in Disarmed State
- Option 2 - Listen-in Enabled when dialling only and in Armed State
- Option 3 - Listen-in Enabled when dialling only and in Monitor Mode
- Option 4 - Listen-in Enabled through the entire call only in Disarmed state
- Option 5 - Listen-in Enabled through the entire call only in Armed State
- Option 6 - Listen-in Enabled through the entire call only in Monitor Mode
- Option 7 - Listen-in Enabled when the panel answers a call
- Option 8 - Listen-in on at All Times

The panel provides the facilities to use the buzzer in the keypad as a speaker to listen to the call being made by the dialler. To use this feature a 5th wire must be connected between the panel and a keypad using the listen-in terminals. The options above allow many combinations of the listen-in to be used or it can be disabled by selecting no options.

### Output # 1 Listen-In Options

**OUTPUT # 1 LISTEN-IN OPTIONS** - P175E 7E

- Option 1 - Listen-in Enabled when dialling only and in Disarmed State
- Option 2 - Listen-in Enabled when dialling only and in Armed State
- Option 3 - Listen-in Enabled when dialling only and in Monitor Mode
- Option 4 - Listen-in Enabled through the entire call only in Disarmed state
- Option 5 - Listen-in Enabled through the entire call only in Armed State
- Option 6 - Listen-in Enabled through the entire call only in Monitor Mode
- Option 7 - Listen-in Enabled when the panel answers a call
- Option 8 - Listen-in on at All Times

The panel provides the facilities to use a speaker connected to Output # 1 to listen to the call being made by the dialler. For this to happen the device connected to output # 1 must be an 8Ω horn speaker. The options above allow many combinations of the listen-in to be used or it can be disabled by selecting no options.

## Dialling Pre-Fix Number

**DIALLING PRE-FIX NUMBER** - P175E 8E (Value 1-16 digits)

The panel can be programmed with a Pre-fix telephone number. The Pre-fix number can be up to 16 digits long. The Pre-fix number can be dialled before any of the 8 Telephone numbers if required (P183E Option 7).

## Keypad Panic, Fire and Medical Alarms CID Report Code

### “PANIC” ALARM CONTACT ID REPORT CODE

**“PANIC” ALARM CONTACT ID REPORT CODE** - P175E 9E (3 digit event code)

Normally a keypad initiated Panic alarm would default to reporting a standard “Panic Alarm” code of “120”. If the panic alarm is being used for some other purpose and you need to identify the correct type of alarm event you can change the event code at this location.

### “FIRE” ALARM CONTACT ID REPORT CODE

**“FIRE” ALARM CONTACT ID REPORT CODE** - P175E 10E (3 digit event code)

Normally a keypad initiated Fire alarm would default to reporting a standard “Fire Alarm” code of “110”. If the fire alarm is being used for some other purpose and you need to identify the correct type of alarm event you can change the event code at this location.

### “MEDICAL” ALARM CONTACT ID REPORT CODE

**“MEDICAL” ALARM CONTACT ID REPORT CODE** - P175E 11E (3 digit event code)

Normally a keypad initiated Medical alarm would default to reporting a standard “Medical Alarm” code of “100”. If the medical alarm is being used for some other purpose and you need to identify the correct type of alarm event you can change the event code at this location.

## Output, Microphone & Voice Kiss OFF DTMF Remote Codes

### OUTPUT DTMF CONTROL CODE NUMBER

**OUTPUT DTMF CONTROL CODE NUMBER** - P175E 12E (Value 1-4 digit code 0-9999)

The panel can be configured to allow remote operation of the Outputs via a remote telephone. The code programmed at this address is the DTMF code that must be used when performing this function. When dialling the panel and it has answered the call, after waiting for the panel modem tones to stop you can enter in the 4 digit DTMF code plus the Output number you wish to control, eg <1> for Output # 1, and the current status will be given of the Output associated with the code entered. After that, if you press the “\*” button on the telephone the status of the output will toggle eg if it was previously On it will change to Off or vice versa. When finished you simply hang-up and 15 seconds later the panel will release the line.

## MICROPHONE ON/OFF DTMF CODE NUMBER

### *Monitor DTMF*

#### **MICROPHONE ON/OFF DTMF CODE NUMBER - P175E 13E (Value 1-4 digit code 0-9999)**

The panel can be configured to allow remote listen-in via an on-site microphone. The Voice Board must be fitted for the microphone feature to be available. The code programmed at this address is the DTMF code that must be used when turning the microphone On or Off. When dialling the panel and it has answered the call, after waiting for the panel modem tones to stop you can enter in the 4 digit DTMF code plus the <\*> button on the telephone. This will turn the Microphone On. By Pressing the <\*> button again the microphone will be turned Off. When finished you simply hang-up and 15 seconds later the panel will release the line.

## DIALLER ACKNOWLEDGE DTMF CODE NUMBER

#### **DIALLER ACKNOWLEDGE DTMF CODE NUMBER - P175E 14E (Value 1-4 digit code 0-9999)**

If the panel is set to report in Domestic or Voice reporting formats, you can simply kiss-off (acknowledge) the alarm by pressing the <#> button on the remote telephone. Alternatively if you require a more secure kiss-off method to ensure that the alarm is only kissed off by the correct person you can program a 1-4 digit code at this location. If a code is programmed at this location you must enter in the code followed by the <#> button to kiss-off the alarm event.

## FORCE TEST CALL DTMF CODE NUMBER

#### **FORCE TEST CALL DTMF CODE NUMBER - P175E 15E (Value 1-4 digit code 0-9999)**

If a user wishes to remotely force a test call from the panel to a monitoring company using the Contact ID test message, you can dial the panel and when it answers enter the code programmed at this location on the telephone.

If a voice board is fitted you can assign a voice message (see P176E11E below) to indicate that the function was started. If no voice board is fitted but there is a DTMF IC fitted to the panel you will get 3 short beeps after the code is entered to indicate the function was started. Once you hang-up the phone the panel will then make a call to the monitoring company and send a manual test call message. If no code is programmed at this location (ie "0") the function will be disabled. The code can be a 1-4 digit number as required.

NOTE: If using this remote test code and any of the other remote DTMF codes at locations (P63E, P175E12E, P175E13E & P175E14E) you should make this code a 4 digit code to ensure the panel knows what function is being operated. If no other DTMF remote functions are being used this code can be a single digit.

It is also possible to force a locally generated test call from the panel keypad by pressing and holding the <CONTROL> button then <0> within two seconds of pressing control. This will force a test call to the monitoring company.

## Miscellaneous Voice Reporting Message Numbers

KEYPAD or RADIO PANIC ALARM VOICE MESSAGE NUMBER -	P176E 1E (Value 0-99)
FIRE ALARM VOICE MESSAGE NUMBER -	P176E 2E (Value 0-99)
MEDICAL ALARM VOICE MESSAGE NUMBER -	P176E 3E (Value 0-99)
AC FAIL ALARM VOICE MESSAGE NUMBER -	P176E 4E (Value 0-99)
AC RESTORE VOICE MESSAGE NUMBER -	P176E 5E (Value 0-99)
BATTERY LOW ALARM VOICE MESSAGE NUMBER -	P176E 6E (Value 0-99)
BATTERY RESTORE VOICE MESSAGE NUMBER -	P176E 7E (Value 0-99)
TAMPER ALARMS VOICE MESSAGE NUMBER -	P176E 8E (Value 0-99)
DURESS ALARM VOICE MESSAGE NUMBER -	P176E 9E (Value 0-99)
LATCHKEY DISARM VOICE MESSAGE NUMBER -	P176E 10E (Value 0-99)
MANUAL TEST CALL INITIATED VOICE MESSAGE NUMBER -	P176E 11E (Value 0-99)

If a Voice Board is connected to the panel it is possible to send various alarm messages to identify the type of alarm. If the above locations are programmed with a "0" then the event will not report in Voice or Domestic format.

# Telephone Numbers

## Programming Telephone Numbers

### Telephone Numbers

**TELEPHONE NUMBERS** - P181E 1-8E (Value 1-16 digit number)

The Telephone Numbers can be up to 16 digits long. They can also include some special functions or characters as per the chart below.

LED KEYPAD BUTTON	LED KEYPAD INDICATION	LCD KEYPAD BUTTON	LCD KEYPAD CID & 4+2 INDICATIONS	LCD KEYPAD TELEPHONE INDICATIONS	CID & 4+2 SPECIAL CHARACTERS	TELEPHONE NUMBER SPECIAL FUNCTION
"BYPASS"	-	CONTROL & 0	-	DELETE #	DELETE #	DELETE #
"PANIC"	11	CONTROL & 2	B	#	"B"	"#"
"MEMORY"	12	CONTROL & 3	C	*	"C"	"*"
"CONTROL"	13	CONTROL & 4	D	-	"D"	"2.5 sec Pause"
"ARM"	14	CONTROL & 5	E	w	"E"	"Wait for 2nd Dial-tone"
"STAY"	15	CONTROL & 6	F	=	"F"	"5 sec Pause"

## Reporting Formats

### Telephone Number Report Formats

**TELEPHONE NUMBER REPORT FORMATS** - P182E 1-8E

Option 1 - Contact ID

Option 2 - Domestic Dial

Option 3 - Pager

Option 4 - Voice Dialler

Option 5 - 4 + 2 (Pulsed) 10 pps (1400 Hz Handshake, 1900 Hz transmit Tone)

Option 6 - 4 + 2 (Pulsed) 10 pps (2300 Hz Handshake, 1800 Hz transmit Tone)

Option 7 - 4 + 2 (Pulsed) 20 pps (1400 Hz Handshake, 1900 Hz transmit Tone)

Option 8 - 4 + 2 (Pulsed) 20 pps (2300 Hz Handshake, 1800 Hz transmit Tone)

Option 9 - 4 + 2 DTMF (with Checksum)

Option 1 **Contact ID** - If this option is set for the telephone number, the panel will send a Contact ID message to a Monitoring Station.

Option 2 **Domestic Dial** - If this option is set for the telephone number, the panel is expecting to dial a residential telephone number when an alarm occurs. The message sent consists of a siren tone over the phone to alert the person called that an alarm is in progress. The alarm can be cancelled by the person called by pressing the "#" button on a touch tone phone during the quiet period. If there is a code programmed at location P175E14E the alarm must be kissed off by entering in the code then "#". If the alarm is cancelled by a valid user code the dialler will stop any further calls. If Option 1 at P46E is turned on (use near and confirmed alarm reporting) the panel will not send an alarm in this format.

Option 3 **Pager** - Report alarm events using "Pager" format. This format utilizes Telecom's 026 pager network or other public subscriber networks, etc, to send numeric messages to a compatible pager. The panel sends a 12 digit numeric number to the pager consisting of the account code (P62E) the 3 digit CID event code for the alarm event and a 3 digit zone number to identify the zone in alarm.

Option 4 **Voice Dialler** - If the optional voice board is fitted to the panel then selecting this option for the telephone number will allow preset voice messages to be sent via the telephone following an alarm. The kiss off method to acknowledge the alarm message is the same as the Domestic Format. If Option 1 at P46E is turned on (use near and confirmed alarm reporting) the panel will not send an alarm in this format.

Option 5 **4 + 2 (10 pps)** - This option transmits a 4 digit account code followed by a 2 digit event code to a central monitoring station. The handshake tone from the monitoring station must be 1400 Hz and the transmit tone from the panel will be at 1900Hz at 10 pulses per second.

Option 6 **4 + 2 (10 pps)** - This option transmits a 4 digit account code followed by a 2 digit event code to a central monitoring station. The handshake tone from the monitoring station must be 2300 Hz and the transmit tone from the panel will be at 1800Hz at 10 pulses per second.

Option 7 **4 + 2 (20 pps)** - This option transmits a 4 digit account code followed by a 2 digit event code to a central monitoring station. The handshake tone from the monitoring station must be 1400 Hz and the transmit tone from the panel will be at 1900Hz at 20 pulses per second.

Option 8 **4 + 2 (20 pps)** - This option transmits a 4 digit account code followed by a 2 digit event code to a central monitoring station. The handshake tone from the monitoring station must be 2300 Hz and the transmit tone from the panel will be at 1800Hz at 20 pulses per second

Option 9 **4 + 2 (DTMF)** - This option transmits a 4 digit account code followed by a 2 digit event code plus a checksum using DTMF signals to a central monitoring station. The handshake tone from the monitoring station must be 1400 Hz /2300 Hz.

## TELEPHONE NUMBER REPORT OPTIONS

### TELEPHONE NUMBER REPORT OPTIONS - P183E 1-8E

Option 1 - Stop Dialling if Kissed Off

Option 2 - Monitor Call Progress

Option 3 - Blind Dial

Option 4 - Use Group Numbers for Contact ID Reporting

Option 5 - Spare

Option 6 - Auto Kiss-off for Voice/Domestic Reporting

Option 7 - Use the Dial Pre-fix Number

Option 8 - Used as the Call-back Number

Option 1 **Stop if Kissed Off** - If this option is turned on for the telephone number, the dialler will stop sending the alarm if the signal is kissed off and will not proceed with any other telephone numbers for that event. If not kissed off the dialler will start dialling any other programmed numbers. If the event is not kissed off from any of the

telephone numbers and the maximum re-tries limit is reached then the event is marked as unsent and will be added to the next event that causes the dialler to report. If this option is off, the dialler will send the event for the maximum re-tries count or until kissed off but it will then proceed to report the same event to any other telephone numbers programmed.

- Option 2 **Monitor Call Progress** - Monitor call progress means that the dialler monitors the status of the dialling tones to determine whether the call is valid or not. If the call is not valid, eg engaged, the panel will know and hang up the call and try again.
- Option 3 **Blind Dial** - When the dialler makes a call it looks for dial tone before making the call. If no dial tone is detected the panel hangs up and attempts another call. The panel will do this 3 times and if dial tone is still not detected it will make the call anyway. If blind dial is on, the panel skips the dial tone detection and dials 4 seconds after looping the line (used where non standard or low level dial tone exists).
- Option 4 **Use Group Numbers for Contact ID Reporting** - When sending an alarm using Contact ID, the panel can send separate account codes to report the two areas or, use one account code (P62E1E Area A) and use the group number to identify the two areas. Turning this option on sends one account with group numbers.
- Option 5 **Spare** -
- Option 6 **Auto Kiss-off for Voice/Domestic reporting** - If Voice or Domestic Report Format is used and this option is turned On, the alarm will be reported and it can be kissed off by entering the kiss-off code (P175E14E) at the telephone but if not kissed off the event is automatically removed from the dialler buffer once the maximum dial re-tries has been reached for the telephone number. A new event must then be created before the dialler will dial again.
- Option 7 **Use the Dial Pre-fix Number** - If the Telephone number does not provide sufficient digits for dialling purposes it is possible to program a dial pre-fix number (P175E8E). The pre-fix can be dialled before the telephone number. Turning this option on dials the pre-fix first followed by the telephone number.
- Option 8 **Used as the Call-back Number** - Any of the 8 telephone numbers can be designated as the Call-back number. A Call-back number is normally used to allow the panel to dial a preset number and connect to a modem for upload/download purposes.

## Maximum Dial Re-Tries per Telephone Number

**MAXIMUM DIAL RE-TRIES per TELEPHONE NUMBER** - P184E 1-8E (Value 0-99)

The maximum dial re-tries is the number of times that the panel will dial a telephone number in an attempt to get kissed-off.

## Dial Progress Options

### Dialler Reporting Options "A"

**DIALLER REPORTING OPTIONS "A"** - P186E 1-8E

- Option 1 - Report Mains Fail
- Option 2 - Report Battery Low
- Option 3 - Report Radio Battery Low
- Option 4 - Report Line Fail
- Option 5 - Report System Tamper
- Option 6 - Report Keypad Tamper
- Option 7 - Report Zone Tamper
- Option 8 - Report Radio Zone Tamper

- Option 1 **Report Mains Fail** - If this option is on the panel will report a Mains fail after the report delay time (P25E6E) has expired.
- Option 2 **Report Battery Low** - If this option is on the panel will report a Battery Low.
- Option 3 **Report Radio Battery Low** - If this option is on the panel will report a Battery Low from any radio zones that have the battery status monitored.
- Option 4 **Report Line Fail** - If this option is on the panel will report a Telephone Line fail. The panel will send the line fail and the line restore at the same time.
- Option 5 **Report System Tamper** - If this option is on the panel will report a Tamper Alarm on the panel tamper input.
- Option 6 **Report Keypad Tamper** - If this option is on the panel will report a Tamper Alarm from a keypad fitted with a tamper switch or a wrong code alarm from a keypad.
- Option 7 **Report Zone Tamper** - If this option is on the panel will report a Zone Tamper Alarm.
- Option 8 **Report Radio Zone Tamper** - If this option is on the panel will report a Radio Zone Tamper Alarm.

## Dialler Reporting Options "B"

### DIALLER REPORTING OPTIONS "B" - P187E 1-8E

- Option 1 - Report Duress
  - Option 2 - Report Supervised Radio Alarm
  - Option 3 - Report Zone Inactivity Alarm
  - Option 4 - Report Manual Panic Alarm
  - Option 5 - Report Manual Fire Alarm
  - Option 6 - Report Manual Medical Alarm
  - Option 7 - Report Radio Pendant Panic Alarm
  - Option 8 - Report Zone Bypasses
- Option 1 Report Duress - If this option is on the panel will report a Duress Alarm (see P25E2E).
  - Option 2 Report Supervised Radio Alarm - If this option is on the panel will report a Supervised radio Alarm (see P25E4E).
  - Option 3 Report Zone Inactivity Alarm - If this option is on the panel will report a Zone Inactivity (Sensor-watch) Alarm (see P163E).
  - Option 4 Report Manual Panic Alarm - If this option is on the panel will report a Keypad generated Panic Alarm.
  - Option 5 Report Manual Fire Alarm - If this option is on the panel will report a Keypad generated Fire Alarm.
  - Option 6 Report Manual Medical Alarm - If this option is on the panel will report a Keypad generated Medical Alarm.
  - Option 7 Report Radio Pendant Panic Alarm - If this option is on the panel will report a Panic Alarm generated by a radio key (pendant).
  - Option 8 Report Zone Bypasses - If this option is on the panel will report a Manual or Auto Bypass on a zone.

## Dialler Reporting Options "C"

### DIALLER REPORTING OPTIONS "C" - P188E 1-8E

- Option 1 - Report Arm/Disarm
- Option 2 - Report Stay Mode Arm/Disarm
- Option 3 - Report Disarm only after an Alarm
- Option 4 - Report Stay Mode Disarm only after an Alarm
- Option 5 - Report Stay Mode Zone Alarms
- Option 6 - Report Access to Program Mode

- Option 7 - Report 24 Hour Alarms for Domestic/Voice Formats
- Option 8 - Report Zone Restores
- Option 1 **Report Arm/Disarm** - If this option is on then all Arm/Disarm signals will be reported to a Monitoring Station if Contact ID or 4 + 2 is set as the reporting format.
- Option 2 **Report Stay Mode Arm/Disarm** - If this option is on then all Stay Mode Arm/Disarm signals will be reported to a Monitoring Station if Contact ID or 4 + 2 is set as the reporting format.
- Option 3 **Send Disarm only after an Alarm** - If this option is on, the panel will not normally send an Arm/Disarm signal to the monitoring company, however, if a zone alarm occurs then the panel will send a Disarm following the disarming of the panel to show it has been turned off by a valid user.
- Option 4 **Send Stay Mode Disarm only after an Alarm** - If this option is on, the panel will not normally send a Stay Mode Arm/Disarm signal to the monitoring company, however, if a zone alarm occurs then the panel will send a Stay Mode Disarm following the disarming of the panel to show it has been turned off by a valid user.
- Option 5 **Report Stay Mode Zone Alarms** - If this option is on, the panel will report zone alarms in Stay Mode.
- Option 6 **Report Access to Program Mode** - If this option is on the panel will report a Contact ID code to indicate that either Client or Installer program Modes have been accessed.
- Option 7 **Report 24 Hour Alarms for Domestic/Voice Formats** - When the panel is set to send alarms via domestic or voice mode, No alarms will normally be sent for 24 hour zones. If 24 hour alarms are required to be reported in Domestic/Voice mode then this option must be turned on.
- Option 8 **Report Zone Restores** - If this option is on the panel will report all zone restores in Contact ID or 4 + 2 formats. If this option is turned off the panel will only report the alarms.

## Dialler Reporting Options "D"

### DIALLER REPORTING OPTIONS "D" - P189E 1-8E

- Option 1 - Report Latchkey Disarm
- Option 2 - Report Delinquency Alarm
- Option 3 - Report Test Calls
- Option 4 - Report Fuse Failure
- Option 5 - Report Output 1 or 2 Fail
- Option 6 - Spare
- Option 7 - Spare
- Option 8 - Spare
- Option 1 **Report Latchkey Disarm** - If the panel is armed in Latchkey Report Mode by using a Code, Key-switch, <ARM>, <STAY>, <A> or <B> buttons, any code or key-switch without the Latchkey option (P4E or P122E Option 6 off) used to Disarm the Alarm will cause a Disarm report to be sent via the dialler. Normally the report format for the telephone number would be set to Domestic or Voice reporting.
- Option 2 **Report Delinquency Alarm** - If the panel has been configured for Delinquency monitoring (P67E) and an area has not been armed for the time set at P67E, a Delinquency Alarm will be sent to the Monitoring Station if Contact ID or 4 + 2 is set as the reporting format.
- Option 3 **Send Test Calls** - If Contact ID or 4 + 2 formats are used for reporting alarm, the panel can also send Automatic test calls. If this option is turned on the test calls will be sent but if test calls are not required they can be disabled by turning this option off.
- Option 4 **Report Fuse Failure** - The panel has two on-board thermal fuses designed to protect the 12v DC outputs from short circuits. If this option is on and either of these fuses are open, a report will be sent to the monitoring station if Contact ID is set as the reporting format.

- Option 5 **Report Output 1 or 2 Fail** - The panel has two high current Outputs (O/P 1 & 2). These Outputs are normally used to drive sirens or strobes for local alarm warning. If option 8 at location P37E is on for either O/P 1 or 2 the Output status will be monitored (eg wire to siren has been cut). If this option is on and a fault is detected on the output, a report will be sent to the monitoring station if Contact ID is set as the reporting format.

## Call Divert Numbers & Options

### NOTE

**This feature is supported only on New-Zealand and Australia.**

## Call Divert Trigger Events

**CALL DIVERT TRIGGER EVENTS** - P192E 1-2E (1 = Area A Trigger Events, 2 = Area B Trigger Events)

- Option 1 - Divert on Arm  
Option 2 - Divert on Disarm  
Option 3 - Divert on Stay Mode Arm  
Option 4 - Divert on Stay Mode Disarm  
Option 5 - Divert on Key-switch Arm/Disarm  
Option 6 - Divert on Time-zone Arm/Disarm  
Option 7 - Divert on DTMF or PC Arm/Disarm  
Option 8 - Divert on single button <ARM> or <STAY>
- Option 1 **Divert Arm** - If this option is on then the Call-Divert On number (P194E1E) will be dialled when the system is Armed. The User Code must have call divert assigned at P4E option 7 for it to happen. If a User Code does not have option 7 on at P4E the call divert number will not be dialled (used for cleaner codes and others who should not be able to remove the call divert function).
- Option 2 **Divert on Disarm** - If this option is on then the Call-Divert Off number (P194E2E) will be dialled when the system is Disarmed. The User Code must have call divert assigned at P4E option 7 for it to happen. If a User Code does not have option 7 on at P4E the call divert number will not be dialled (used for cleaner codes and others who should not be able to remove the call divert function).
- Option 3 **Divert on Stay Mode Arm** - If this option is on then the Call-Divert On number (P194E1E) will be dialled when the system is Armed in Stay Mode. The User Code Must have call divert assigned at P4E option 7 for it to happen. If a User Code does not have option 7 on at P4E the call divert number will not be dialled (used for cleaner codes and others who should not be able to remove the call divert function).
- Option 4 **Divert on Stay Mode Disarm** - If this option is on then the Call-Divert Off number (P194E2E) will be dialled when the system is Stay Mode Disarmed. The User Code must have call divert assigned at P4E option 7 for it to happen. If a User Code does not have option 7 on at P4E the call divert number will not be dialled (used for cleaner codes and others who should not be able to remove the call divert function).
- Option 5 **Divert on Key-switch Arm/Disarm** - If this option is on then the Call-Divert On and Off numbers (P194E1E & 2E) will be dialled when the system is Armed or Disarmed with the key-switch.
- Option 6 **Divert on Time-zone Arm/Disarm** - If this option is on then the Call-Divert On and Off numbers (P194E1E & 2E) will be dialled when the system is Armed or Disarmed by a Time-zone.
- Option 7 **Divert on DTMF or PC Arm/Disarm** - If this option is on then the Call-Divert On and Off numbers (P194E1E & 2E) will be dialled when the system is Armed or Disarmed by a Remote DTMF code or by a PC connection.

- Option 8 **Divert on single button <ARM> or <STAY>** - If this option is on then the Call-Divert On number (P194E1E) will be dialled when the system is Armed with the <ARM> or <STAY> buttons. This option must be selected if the Call Divert function is required and single button arming is being used.

## Call Divert Numbers & Options

### NOTE

**This feature is supported only on New-Zealand and Australia.**

### Divert Number Dial Options

**DIVERT NUMBER DIAL OPTIONS** - P193E 1-2E (1 = Divert ON Number, 2 = Divert OFF number)

Option 1 - Spare

Option 2 - Spare

Option 3 - Blind Dial

Option 4 - Spare

Option 5 - Spare

Option 6 - Spare

Option 7 - Use the Dial Pre-fix Number

Option 8 - Spare

Option 1 **Spare**

Option 2 **Spare**

Option 3 **Blind Dial** - When the dialler makes a divert call it looks for dial tone before making the call. If no dial tone is detected the panel hangs up and attempts another call. The panel will do this 3 times and if dial tone is still not detected it will make the call anyway. If blind dial is on, the panel skips the dial tone detection and dials 4 seconds after looping the line (used where non standard or low level dial tone exists).

Option 4 **Spare**

Option 5 **Spare**

Option 6 **Spare**

Option 7 **Use the Dial Pre-fix Number** - If the Divert number does not provide sufficient digits for dialling purposes it is possible to program a dial pre-fix number (P175E8E). The pre-fix can be dialled before the divert number. Turning this option on dials the pre-fix first followed by the divert number.

Option 8 **Spare**

### Divert Number

**DIVERT NUMBER** - P194E 1-2E (Value 1-16 digits) (1 = Divert ON Number, 2 = Divert OFF number)

The call divert numbers are programmed at this location. They are the numbers that must be dialled to turn the divert On or Off. Option 1 turns call divert **ON** and Option 2 turns the call divert **OFF**.

# 4+2 Program Options

When using the 4+2 Reporting Format the two digit report code can be changed if desired at the locations below. Also the two digit codes can include the numbers 0-9 as well the special characters B,C,D,E & F. The chart below shows how to program the special 4+2 characters.

## Using the 4+2 Codes

### Armed By User 4+2 Code ( User Arm )

**ARMED by USER 4+2 CODE** - P16E 1-100E User Number (Value 00-FF)

### Disarmed By User 4+2 Code ( User open )

**DISARMED by USER 4+2 CODE** - P17E 1-100E User Number (Value 00-FF)

### Zone Alarm 4+2 Code

**ZONE ALARM 4+2 CODE** - P147E 1-16E Zone Number (Value 00-FF)

### Zone Alarm Restore 4+2 Code

**ZONE ALARM RESTORE 4+2 CODE** - P148E 1-16E Zone Number (Value 00-FF)

### Zone Near Alarm 4+2 Code

**ZONE NEAR ALARM 4+2 CODE** - P149E 1-16E Zone Number (Value 00-FF)

### Zone Near Alarm Restore 4+2 Code

**ZONE NEAR ALARM RESTORE 4+2 CODE** - P150E 1-16E Zone Number (Value 00-FF)

### Zone Confirmed Alarm 4+2 Code

**ZONE VERIFIED ALARM 4+2 CODE** - P151E 1-16E Zone Number (Value 00-FF)

### Zone Confirmed Alarm Restore 4+2 Code

**ZONE VERIFIED ALARM RESTORE 4+2 CODE** - P152E 1-16E Zone Number (Value 00-FF)

### Zone Bypass 4+2 Code

**ZONE BYPASS 4+2 CODE** - P155E 1-16E Zone Number (Value 00-FF)

### Zone Bypass Restore 4+2 Code

**ZONE BYPASS RESTORE 4+2 CODE** - P156E 1-16E Zone Number (Value 00-FF)

## Mains/Battery/Tamper/Duress & Arming 4+2 Codes

### AC Fail 4+2 Code

MAINS FAIL 4+2 CODE - P195E 1E (Value 00-FF)

### AC OK 4+2 Code

MAINS FAIL RESTORE 4+2 CODE - P195E 2E (Value 00-FF)

### Battery Low 4+2 Code

BATTERY LOW 4+2 CODE - P195E 3E (Value 00-FF)

### Battery OK 4+2 Code

BATTERY LOW RESTORE 4+2 CODE - P195E 4E (Value 00-FF)

### System Tamper 4+2 Code

SYSTEM TAMPER 4+2 CODE - P195E 5E (Value 00-FF)

### System Tamper Restore 4+2 Code

SYSTEM TAMPER RESTORE 4+2 CODE - P195E 6E (Value 00-FF)

### DTMF or PC Arm 4+2 Code

DTMF or PC ARM 4+2 CODE - P195E 7E (Value 00-FF)

### DTMF or PC Disarm 4+2 Code

DTMF or PC DISARM 4+2 CODE - P195E 8E (Value 00-FF)

### Duress ALARM 4+2 CODE

DURESS ALARM 4+2 CODE - P195E 9E (Value 00-FF)

### Automatic Test Call 4+2 Code

AUTOMATIC TEST CALL 4+2 CODE - P195E 10E (Value 00-FF)

### Armed By <Arm> Button 4+2 Code

ARMED by <ARM> BUTTON 4+2 CODE - P195E 11E (Value 00-FF)

### Stay Mode Arm 4+2 Code

STAY MODE ARM 4+2 CODE - P195E 12E (Value 00-FF)

### Disarmed By <Arm>or <Stay> Button 4+2 Code

DISARMED by <ARM> or <STAY> BUTTON 4+2 CODE - P195E 13E (Value 00-FF)

## ARMED by KEY-SWITCH 4+2 CODE

ARMED by KEY-SWITCH 4+2 CODE - P195E 14E (Value 00-FF)

## DISARMED by KEY-SWITCH 4+2 CODE (OPEN)

DISARMED by KEY-SWITCH 4+2 CODE - P195E 15E (Value 00-FF)

## FAIL to ARM by TIME-ZONE 4+2 CODE

FAIL to ARM by TIME-ZONE 4+2 CODE - P195E 16E (Value 00-FF)

## "Panic" Alarm 4+2 Code

"PANIC" ALARM 4+2 CODE - P195E 17E (Value 00-FF)

## "Panic" Alarm OK 4+2 Code

"PANIC" ALARM RESTORE 4+2 CODE - P195E 18E (Value 00-FF)

## "Fire" Alarm 4+2 Code

"FIRE" ALARM 4+2 CODE - P195E 19E (Value 00-FF)

## "Fire" Alarm OK 4+2 Code

"FIRE" ALARM RESTORE 4+2 CODE - P195E 20E (Value 00-FF)

## "Medical" Alarm 4+2 Code

"MEDICAL" ALARM 4+2 CODE - P195E 21E (Value 00-FF)

## "Medical" Alarm OK 4+2 Code

"MEDICAL" ALARM RESTORE 4+2 CODE - P195E 22E (Value 00-FF)

# Diagnostic & Default Options

## Display Software Version, Keypad Number and Keypad Areas

### Panel Software Version Number

PANEL SOFTWARE VERSION NUMBER - P200E 1E

This location will display the software version of the panel.

### Keypad Address Number

KEYPAD ADDRESS NUMBER - P200E 2E

This location will display the keypad number of the keypad currently in program mode.

### Areas Assigned To the Keypad

**AREAS ASSIGNED to the KEYPAD** - P200E 3E

This location will display the Areas assigned to the keypad currently in program mode.

## Display Active Time Zones & Battery Voltage

### Display Time-Zones Currently Active

**DISPLAY TIME-ZONES CURRENTLY ACTIVE** - P200E 4E

This location will display which of the 8 Time-zones are currently on.

### Display Battery Voltage

**DISPLAY BATTERY VOLTAGE** - P200E 5E

This location will display the system battery voltage measured by the panel.

## Start Walk Test Mode

### Walk Test Mode

**WALK-TEST MODE** - P200E 6E

This address is used to start walk-test mode while in installer or client program mode. By pressing P200E6E at the keypad, the keypad buzzer will beep at 1 second intervals to indicate walk-test mode is active. If a siren is connected to an Output and that output has option 1 turned on at location P36E the siren will give a 1 second beep every time a zone is triggered while walk-test mode is active. By walking past all of the detectors connected to the system and activating them, the associated zone will latch up at the keypad to allow verification that all zones are working properly. By pressing the <Program> or <Enter> button, walk-test mode will be terminated and the panel will leave program mode. The

results of the walk-test will be saved in the memory event buffer and can be viewed by accessing memory display mode to verify which detectors were triggered during walk-test mode. If Output 1 or 2 are used for the Audible walk-test indication and a horn speaker is connected to the output (see P37E1 or 2E option 1), the siren on the output will give a single tone for the chirp instead of the swept tone used for alarms.

## Read or Write to the DTU

### Write To EEPROM (DTU) Board

#### **WRITE to EEPROM [DTU] BOARD - P200E 7E**

This location is used to copy the panels program configuration to an external EEPROM memory card (DTU-Data Transfer Unit) which can be plugged into the expansion socket on the control board. The write protect link on the DTU board must be ON for the data to be transferred.

### Read From EEPROM (DTU) Board

#### **READ from EEPROM[DTU] BOARD - P200E 8E**

This location is used to return the panels program configuration from an external EEPROM memory card (DTU-Data Transfer Unit) which can be plugged into the expansion socket on the control board.

## Restore Defaults

### Default Codes & Telephone Numbers

#### **DEFAULT CODES & TELEPHONE NUMBER - P200E 9E**

This location is used to return the panels User and Installer Codes plus the Telephone Numbers & Account Codes to the default settings.

### Default All Programming to Factory Settings

#### **DEFAULT ALL PROGRAMMING TO FACTORY SETTINGS - P200E 10E**

This location is used to return the panels User and Installer Codes plus the Telephone Numbers & Account Codes to the default settings.

## Clear Memory Buffer

### Clear Alarm Memory Buffer

#### **CLEAR ALARM MEMORY BUFFER - P200E 11E**

This location is used to clear ALL of the events stored on memory.

## Start a Call-Back Call

### Initiate a Call to the Call-Back Number

#### **INITIATE A CALL to the CALL-BACK NUMBER - P200E 12E**

This location is used to force a call to the call-back number.

# User Privileges Chart

Program Location		P5E Options:							
		Option 1: Change own code	Option 2: Change others codes	Option 3: Full access	Option 4: Change phone numbers	Option 5: Change clock	Option 6: Change DTMF command	Option 7: Learn new radio devices	Option 8: Can force download
		1	2	3	4	5	6	7	8
P1E	User codes	X	X	X					
P2E	User type			X					
P3E	User areas			X					
P4E	User access			X					
P5E	User privileges			X					
P7E	User pendant type			X					
P8E	User radio privileges			X					
P9E	User time zones			X					
P18E	Learn radio user								X
P19E	Delete radio user								X
P20E	Find radio user								X
P21E	Learn radio user								X
P22E	Delete radio user								X
P23E	Find radio user								X
P25E12E	User options (hide user codes to installer)		X						
P26E (all)	Time/Date and Daylight Savings					X			
P170E	Change Holidays					X			
P63E	Area A & B Command Code						X		
P164E	Learn radio zone								X
P165E	Delete radio zone								X
P166E	Find radio zone								X
P175E3E	Auto-answer rings				X				
P175E4E	Time to first test call				X				

P5E Options:									
	Option 8: Can force download								
	Option 7: Learn new radio devices								
	Option 6: Change DTMF command								
	Option 5: Change clock								
	Option 4: Change phone numbers								
	Option 3: Full access								
	Option 2: Change others codes								
	Option 1: Change own code	1	2	3	4	5	6	7	8
P175E5E	Test call period				X				
P175E8E	Dial prefix				X				
P175E12E	Output DTMF command control code						X		
P175E13E	Microphone DTMF command control code						X		
P175E14E	Voice/Domestic DTMF acknowledge code						X		
P175E15E	Remote test initiate DTMF code						X		
P181E	Telephone numbers				X				
P194E	Divert telephone numbers				X				
P200E1E	Display panel version #		X	X					
P200E2E	Display keypad address		X	X					
P200E3E	Areas assigned to this keypad		X	X					
P200E4E	Display active time zones		X	X					
P200E5E	Display battery voltage		X	X					
P200E6E	Enter walk test mode							X	
P200E12E	Initiate call back			X					X

## Telecom Interface

The dialler facility on this controller has been designed to provide optimum flexibility in the way in which alarm events are reported. This flexibility includes options for reporting to a central monitoring station using Contact ID format, a Domestic reporting option using alternating siren tones, a format for reporting alarms to an alpha numeric pager and a powerful Speech Dialler.

In accordance with the statutory requirements of the Telepermit standards we must bring the following points to your attention;

A readily accessible disconnect device shall be incorporated into the 230V fixed wiring.

In the event of any problem with this device, the by-pass switch should be operated. The user is to then arrange with the installer of the device to make the necessary repairs. Should the matter be reported to Telecom as a wiring fault, and the fault be proven to be due to the alarm panel, a call out charge will be incurred.

Should the control panel require relocation the Telecom connection must be disconnected before the power is disconnected. Similarly when reconnecting the dialler, it is necessary to power up the panel before connecting the dialler to the Telecom Network.

Connection to the Telecom network should be made in accordance with Access Standards Newsletter #65 dated November 1993. This connection is to be readily accessible to allow disconnection in the event of a fault. An example of this connection method is shown below.

### NOTE

**The telephone line must not enter the cabinet through the same cable entry hole as any 230 volt mains cables. A separate cable entry must be used for 230 volt cabling.**

When using one of the knock-outs around the side of the cabinet for supply entry, a suitable bushing must be used where the supply cables pass through a knock-out.

The transmit level from this device is set at a fixed level and because of this there may be circumstances where this device does not give its optimum performance. Before reporting such occurrences as faults, please check the line with a standard Tele-permitted telephone, and do not report a fault unless the telephone performance is impaired.

**This automatic dialling equipment shall not be set up to make calls to the  
Telecom "111" Emergency Service**

# Contact ID Code Summary

In addition to the programmable Contact ID Event Code assignments defined at P157E, P158E, P159E, P175E (10E-12E), there are a number of fixed event codes. The programmable and fixed event codes are all listed in the table below. Associated with the fixed and programmable event codes, there are a number of extension codes that are also listed below. The list of extension codes is for your reference only and can not be changed in programming.

Event Type	Event Code	Extension	Comment
System Tamper	137	000	Panel & Sat Tamper etc
Zone Alarm (wired or wireless)	130	001 to 016	Alarm on Zone 1-16
Zone Tamper - Low (short circuit)	383	001 to 008	Zone Input 1-8 short circuit
Zone Tamper - High (open circuit)	383	009 to 016	Zone Input 1-8 open circuit
Zone Tamper - Radio Zone	383	001 to 016	Radio Zone 1-16
Zone Near Alarm	138	001 to 016	Zone Input 1-16
Zone Confirmed Alarm	139	001 to 016	Zone Input 1-16
Radio PIR / Reed Switch Battery Low	384	001 to 016	Radio Zone 1-16
Radio PIR Supervised Alarm	381	001 to 016	Supervised Radio Zone 1-16
Sensor-watch Alarm	391	001 to 016	Zone 1-16
Zone Excludes	570	001 to 016	Exclude Zone 1-16
Keypad Panic (or 1&3)	120	001 to 008	Panic at keypad #1-8
Radio-Key Panic	120	021 to 100	Panic by Radio User # 21-100
Keypad Fire (4&6)	110	001 to 008	Fire Alarm at keypad #1-8
Keypad Medical (7&9)	100	001 to 008	Medical Alarm at keypad #1-8
Keypad Tamper Switch Alarm	137	101 to 108	Keypad 1-8 Tamper Switch Activated
Wrong Code Alarm	461	001 to 008	4 Incorrect code entries at KP # 1-8
Arm/Disarm by "ARM key (Quick Arm)	408	000	Arm/Disarm by single button
Arm/Disarm by user code	401	001 to 100	Arm/Disarm by User #1-100
Arm/Disarm by Radio-key	400	021 to 100	Arm/Disarm by Radio User #21-100
Arm/Disarm by Key-switch	409	000	Key-switch # 1 Arm/Disarm
	409	001	Key-switch # 2 Arm/Disarm
Arm/Disarm by DTMF or Up/Download	407	000	Remote Arm/Disarm
Arm/Disarm by Time-Zone	403	000	Time-Zone Arm/Disarm
Latchkey Disarm	642	001 to 100	Latchkey User Disarm
Fail to Arm on Time-Zone	455	000	Auto Arm fail

Event Type	Event Code	Extension	Comment
Delinquency Alarm	454	000	System not Armed within # days
Stay Mode Arm/Disarm (part set)	441	000	Arm by "Stay" Button
Stay Mode Arm/Disarm (part set)	441	001 to 100	Stay Mode Arm by User # 1-100
Stay Mode Arm/Disarm by Key-switch	442	000	Stay Mode Arm by Key-switch # 1
Stay Mode Arm/Disarm by Key-switch	442	001	Stay Mode Arm by Key-switch # 2
System Battery Low	302	000	Control Panel Battery low
Mains Fail	301	000	Mains (AC) fail
Fuse Fail	312	000	Fuse 1 or 2 Fail
Radio-key Battery Low	384	021 to 100	Radio-key User #21-100 low batt.
Radio-PIR / Reed Switch Battery Low	384	001 to 016	Radio Zone 1-16
Automatic TEST Calls	602	000	24 hour test
Manual TEST Calls	601	000	User generated Test Call
Phone Line Failure	351	000	Reported when line is restored
Duress Alarm	121	001 to 008	Duress at Keypad #1-8
Program Modes Accessed	628	001 to 008	Program Mode entered at KP # 1-8
Output 1 or 2 Tamper	323	001 or 002	O/P 1 or 2 wires cut.
Type 0 (Short/Loop Circuit)			

# Software change Update Notice

**There are currently no updates.**

# PW8/16 Quick Start Guide

The default settings of this panel have been chosen to allow the system to be up and running with a minimum of programming. Because of this there are normally only a handful of program addresses that need to be changed to get the system fully functional.

As a guide to getting the system up and running as quickly as possible we have summarised the most commonly used addresses for you below.

## **CODES:**

### **P1E 1-100E**

Code 1 is P13E1E and is defaulted to "123". Code 2 is P13E2E, etc up to P13E100E for code 100.

## Enable Dialler

### **P175E 1E**

By default the Dialler is turned Off. To turn On the dialler you must turn on Option 1 at address P175E1E.

## Telephone Numbers

### **P181E 1-8E**

Telephone Number 1 is P181E1E and can be up to 16 digits long. Number 2 is P182E2E, etc up to P181E8E for Phone number 8.

## Telephone Format

### **P182E 1-8E**

There are 9 different reporting formats that can be selected for each telephone number. The formats are listed on page 119.

## Account Code

### **P62E 1-2E**

Area "A" Account code is P62E1E and Area "B" Account code is P62E2E.

## Armed Entry Delays

### **P144E 1-16E**

Zone 1 entry delay is P144E1E and can be a value of 0-9999 seconds through to Zone 16 entry delay being at address P144E16E. A value of "0" makes the zone instant.

## Stay Entry Delays

### **P145E 1-16E**

Zone 1 entry delay when armed in "Stay" Mode is P145E1E and can be a value of 0-9999 seconds through to Zone 16 Stay Mode entry delay being at address P145E16E. A value of "0" makes the zone instant.

## ARMED EXIT DELAY:

### **P60E 1-2E**

Area A exit delay is programmed at P60E1E, Area B at P60E2E and can be a value of 0-255 seconds. A value of "0" makes the area arm instantly with no exit delay.

## STAY EXIT DELAY:

### **P61E 1-2E**

Area A Stay Mode exit delay is programmed at P61E1E, Area B at P61E2E and can be a value of 0-255 seconds. A value of "0" arms Stay Mode instantly with no exit delay.

# PW8/16 CONFIGURATION SUMMARY GUIDE

The following program summary is an abbreviated version of all the panel program addresses. This is intended as a quick guide to finding a program address. In many address locations, there is a main address (e.g. "P1E"), then a sub address (e.g. P1E "1E"). You must enter in the main address number, followed by the sub address, then you can enter the actual data. The program addresses are in numerical order with page references beside them so you can get more detailed information if required. This Summary is split into 11 headings. These are;

- |                                           |          |
|-------------------------------------------|----------|
| 1. Users -                                | Page 131 |
| 2. Miscellaneous Panel & Clock Settings - | Page 135 |
| 3. Outputs -                              | Page 137 |
| 4. Areas -                                | Page 139 |
| 5. Keypads -                              | Page 142 |
| 6. Key-Switches -                         | Page 148 |
| 7. Zones -                                | Page 148 |
| 8. Time Zones -                           | Page 156 |
| 9. Dialler -                              | Page 157 |
| 10. Telephone Numbers -                   | Page 159 |
| 11. Miscellaneous 4+2 Program Options -   | Page 156 |
| 12. Panel Diagnostic & Default Options -  | Page 163 |

# Users

## *Programming User Codes*

**P1E 1-100E User Code 1-100** - Default for User Code # 1 (P1E1E) = 1234  
Codes can be 1-6 or 4-6 digits.

*(where 1E = User Code #1 to 100E = User Code #100)*

**NOTE:** The 100 Users can be keypad Code, Radio or Access key Users. They can be mixed but the Maximum is 100 Users.

The User type MUST be set to "0" (P2E User# E) for a code to be entered at the above addresses.

## *User Type (Code/Radio/Access Tag-Card)*

**P2E 1-100E User # 1-100 Type -** (Default = 0)

- 0 = Keypad Code User {PIN}
- 1 = Radio User (Users 21-100 only)
- 2 = Access Tag/Card User
- 3 = Both Code and Access Tag/Card User {Tag + PIN}
- 4 = Either Code or Access Tag/Card User {Tag or PIN}

## *User Area Assignment*

**P3E 1-100E User # 1-100 Area -** (Default = 1)

- 1 = Assigned to Area "A"
- 2 = Assigned to Area "B"

## *User Code Access Options*

**P4E 1-100E Users 1-100 Access Options** (Default 1-4) (Default = 1,3,4)

- 1 = Code can Arm Area
- 2 = Code can arm Stay Mode
- 3 = Code can Disarm Area
- 4 = Code can disarm Stay Mode
- 5 = Code is a Security Guard Code
- 6 = Code will Arm Latchkey Mode
- 7 = Call Divert Code
- 8 = Spare

## *User Code Privileges*

**P5E 1-100E Users 1-100 Privileges**

- (Default User 1 = ,2,3,4,5,6,7,8)
- (Default User 2-100 = 1)
- 1 = User can Change their Code
- 2 = User can Change All Codes
- 3 = User can Allow Access to Installer Mode/Edit all Codes
- 4 = User can Change Telephone Numbers
- 5 = User can Change the Clock
- 6 = User can Change DTMF Command Codes
- 7 = User can Learn New Radio Devices
- 8 = User can Force a Download to Callback Number

### *Radio User Type*

P7E 21-100E Radio User 21-100 Type

0 = General Pendant Type

(Default = 1) 1 = Crow Freelink Pendant

21 = Ness Pendant

### *Radio User Privileges*

P8E 21-100E Radio Users 21-100 Privileges

1 = Pendant Can Disarm at All Times (Default = 1)

2 = Pendant Causes Immediate Panic

3 = Pendant Causes Delayed Panic ( 1.5 Sec)

4 = Spare

5 = Spare

6 = Spare

7 = Spare

8 = Spare

### *Time Zone Assigned to a User*

P9E 1-100E Time Zone to User # 1-1001 = User Controlled by Time Zone # 1

(Default = All Off) 2 = User Controlled by Time Zone # 2

3 = User Controlled by Time Zone # 3

4 = User Controlled by Time Zone # 4

5 = User Controlled by Time Zone # 5

6 = User Controlled by Time Zone # 6

7 = User Controlled by Time Zone # 7

8 = User Controlled by Time Zone # 8

### *User to Keypad Assignment*

P10E 1-100E User # 1-100 Keypad Assignment

1 = Can Operate at Keypad # 1 (Default = All On)

2 = Can Operate at Keypad # 2

3 = Can Operate at Keypad # 3

4 = Can Operate at Keypad # 4

5 = Can Operate at Keypad # 5

6 = Can Operate at Keypad # 6

7 = Can Operate at Keypad # 7

8 = Can Operate at Keypad # 8

### *Radio Pendant Panic Beeps to Keypad*

P11E 21-100E Radio # 21-100 Panic Beep to Keypad

1 = A Radio panic will Beep at Keypad # 1 (Default = All On)

2 = A Radio panic will Beep at Keypad # 2

3 = A Radio panic will Beep at Keypad # 3

4 = A Radio panic will Beep at Keypad # 4

5 = A Radio panic will Beep at Keypad # 5

6 = A Radio panic will Beep at Keypad # 6

7 = A Radio panic will Beep at Keypad # 7

8 = A Radio panic will Beep at Keypad # 8

### *Users to Output Mask*

#### **P12E 1-100E User # 1-100 to Output Mask**

(Default = All Off)

- 1 = User is Mapped to Output # 1
- 2 = User is Mapped to Output # 2
- 3 = User is Mapped to Output # 3
- 4 = User is Mapped to Output # 4
- 5 = User is Mapped to Output # 5
- 6 = User is Mapped to Output # 6
- 7 = User is Mapped to Output # 7
- 8 = User is Mapped to Output # 8

### *User Can Turn an Output ON*

#### **P13E 1-100E User # 1-100 Can Turn On an Output (Default = All Off)**

- 1 = User Can Turn on Output # 1
- 2 = User Can Turn on Output # 2
- 3 = User Can Turn on Output # 3
- 4 = User Can Turn on Output # 4
- 5 = User Can Turn on Output # 5
- 6 = User Can Turn on Output # 6
- 7 = User Can Turn on Output # 7
- 8 = User Can Turn on Output # 8

### *User Can Turn an Output OFF*

#### **P14E 1-100E User # 1-100 Can Turn Off an Output**

- 1 = User Can Turn off Output # 1 (Default = All Off)
- 2 = User Can Turn off Output # 2
- 3 = User Can Turn off Output # 3
- 4 = User Can Turn off Output # 4
- 5 = User Can Turn off Output # 5
- 6 = User Can Turn off Output # 6
- 7 = User Can Turn off Output # 7
- 8 = User Can Turn off Output # 8

### *Radio Pendant Panic Alarm to an Output*

#### **P15E 21-100E Radio # 21-100 Panic Alarm to an O/P**

- 1 = Radio panic to Output # 1 (Default = 1,2)
- 2 = Radio panic to Output # 2
- 3 = Radio panic to Output # 3
- 4 = Radio panic to Output # 4
- 5 = Radio panic to Output # 5
- 6 = Radio panic to Output # 6
- 7 = Radio panic to Output # 7
- 8 = Radio panic to Output # 8

***Armed by User # 4+2 Reporting Code***

P16E 1-100E 4+2 Arm Code for Users 1-100

***Disarmed by User # 4+2 Reporting Code***

P17E 1-100E 4+2 Disarm Code for Users 1-100

***Learn Radio Pendant Codes***

P18E 21-100E Learn Radio Pendant Codes for Users 21-100

(applies if the User Type, P2E, is set to 1)

***Delete a Specific Radio Pendant Code***

P19E 21-100E Delete a Specific Radio Pendant Code for Users 21-100

(applies if the User Type, P2E, is set to 1)

***Find Radio Pendant memory Location***

P20E 0E Enter this address then operate the Radio Pendant to find its user #

(applies if the User Type, P2E, is set to 1). Only press 0E when using LED Keypad.

***Learn Access Tag/Card Codes***

P21E 1-100E Learn Access Tag/Card Codes for Users 1-100

(applies if the User Type, P2E, is set to 2, 3 or 4)

***Delete a Specific Access Tag/Card Code***

P22E 1-100E Delete a Specific Access Tag/Card Code for Users 1-100

(applies if the User Type, P2E, is set to 2, 3 or 4)

***Find an Access Tag/Card memory Location***

P23E 0E Enter this address then operate the Access Tag/Card to find its user #

(applies if the User Type, P2E, is set to 2, 3 or 4). Only press 0E when using LED Keypad.

## Miscellaneous Panel & Clock Settings

### *Installer Code*

P25E 1E Installer Code - ( Default = 000000)

### *Duress Digit*

P25E 2E Duress Digit - Value 1-9 (Default = 0 Duress Function Disabled)

### *Dial Report Delay*

P25E 3E Dial Report Delay - Value 0-255 seconds (Default = 0)

### *Radio Detector Supervised Timer*

P25E 4E Radio Detector Supervised Timer - 0-9999 Minutes (Default = 240 Minutes [4 Hours])

### *Two Trigger Timer*

P25E 5E Two Trigger Timer - Value 0-255 Seconds (Default = 60 Sec)

### *Mains Fail Reporting Delay*

P25E 6E Mains Fail Reporting Delay - Value 0-9999 Seconds (Default = 900 Sec)

### *Receiver Fail Delay*

P25E 7E Receiver Fail Delay - Value 0-9999 Seconds (Default = 0 Sec-Disabled)

### *Upload/Download Site Code Number*

P25E 8E Upload/Download Site Code Number - Up to 8 Characters (Default = None)

### *Temporary Output Disable*

P25E 9E Temporary Output Disable - Output 1-8

### *Miscellaneous Panel Options*

P25E 10E Misc. Panel Options Miscellaneous Options

(Default = 1,2,6) 1 = Panel Tamper is 2k2 EOL

2 = Direct access to program mode for the installer code.

3 = Disable Mains Fail Test

4 = Listen-in to O/P # 1 Low Volume

5 = Receiver Fail Lockout

6 = Send output information to keypad bus

7 = Cannot arm if the system battery is low

8 = Installer Lockout

### *Installer Options*

P25E 11E Installer Options (Default = All Off)

1 = Entry to installer mode resets confirmed alarms

2 = Entry to installer mode resets tamper alarms

3 = Entry to installer mode resets low battery alarms

4 = Entry to installer mode resets supervisory alarms

5-7 = Spare

8 = User Codes Must be 4-6 digits long

### *User Options*

P25E 12E User Options (NOTE: This Option can ONLY be accessed from Client Mode)

(Default = All Off) 1 = Hide User Codes from Installer

### *Setting Real Time Clock*

P26E 1E Real Time Hour/Minute - Value 0-2359

P26E 2E Real Time Day of Week - Value 1-7 (1=Sunday, 2=Monday ,etc)

P26E 3E Real Time Date/Month/Year - Value DDMMYY (eg 020904 = 2nd Sept 2004)

P26E 4E Daylight Saving is Active (If LED #1 is On, Daylight Saving is currently active) Turn this bit ON if you are in Daylight Saving Time when the panel is installed.

### *Daylight Saving Settings*

**P27E 1E Daylight Saving Start Sunday** - Value 0-5 - Default = 1 (0=daylight saving start time disabled)

**2E Daylight Saving End Sunday** - Value 0-5 - Default = 3 (0=daylight saving end time disabled)

**P28E 1E Daylight Saving Start Month** - Value 1-12 - Default = 10

**2E Daylight Saving End Month** - Value 1-12 - Default = 3

**P29E 1E Daylight Saving Start Hour** - Value 0-23 - Default = 2

**2E Daylight Saving End Hour** - Value 0-23 - Default = 2

## Outputs

### *Programming Output Options "A"*

P34E 1-8E Options "A" for Outputs 1-8

- 1 = Invert Output (Default = All Off)
- 2 = Flash Output
- 3 = Single Pulse to Output
- 4 = Lockout Output
- 5 = DTMF Remote Control can operate Output
- 6 = User Can operate this Output
- 7 = "Control" button Can Operate Output
- 8 = Chime Alarms will Flash this Output (linked to Pulse Timer)

### *Programming Output Options "B"*

P35E 1-8E Options "B" for Outputs 1-8

(Default outputs 1,2 =7)

(Default outputs 3-8 = all off)

- 1 = Mains Fail to Output (Operates when P25E6E time expires) (Default = All Off)
- 2 = Fuse Failure to Output
- 3 = Battery Low to output
- 4 = Telephone Line Failure to Output
- 5 = Supervised Radio Signal Failure
- 6 = Sensor-Watch Alarm
- 7 = System Tamper to Output
- 8 = Receiver Fail

### *Programming Output Options "C"*

P36E 1-8E Options "C" for Outputs 1-8

- 1 = Walk Test Pulse to Output (Default O/P's 1&2 = 1)
- 2 = Pulse Output every 5 seconds when Disarmed (Default O/P's 3-8 = All Off)
- 3 = Pulse Output on Kiss-off Following Arming
- 4 = Spare
- 5 = Spare
- 6 = Spare
- 7 = Spare
- 8 = Spare

### *Programming Output Options "D"*

#### **P37E 1-8E Options "D" for Outputs 1-8**

- 1 = Siren Driver to Output (requires a horn speaker, outputs 1&2) (Default = 8 on for outputs 1,2 only)
- 2 = Output reset timer is minutes (clear for seconds)
- 3 = Output 'silenced' for 10 seconds on key-press if alarm
- 4 =
- 5 =
- 6 =
- 7 =
- 8 = Monitored Output (can tell if siren cable is cut, outputs 1&2 only)

### *Output Delays, Times and Modes*

#### *Output ON Delay Time*

**P38E 1-8E Output 1-8 ON Delay Time - 0-9999 Seconds (Default = 0 Sec)**

#### *Output Pulse Time*

**P39E 1-8E Output 1-8 Pulse Time - 0-255; 1/10th Sec increments (Default = 2)**

#### *Output Reset Time*

**P40E 1-8E Output 1-8 Reset Time - 0-9999 Seconds**  
(if option 2 at P37E is on the reset time is in minutes)

(Default outputs 1,2 = 240)

(Default outputs 3-8 = 0)

#### *Output Chime Mode Time*

**P41E 1-8E Output 1-8 Chime Timer - 0-255; 1/10th Sec increments (Default = 2)**

## Output Command Control

### *Start of Output "Command Control" Status Messages*

**P42E 1-8E Start message Number for Outputs 1-8 "Command Control" - 0-99 (Default = 0)**

### *Un-Map an Output*

**P43E 1-8E Un-map Outputs 1-8 (remove ALL Defaults from an Output) Page 50**

### *Assigning a Time-zone to an Output*

**P44E 1-8E Time-zones that will control Outputs 1-8 - Value = Time-zone 1-8**

## Areas

### *Area "A" & "B" Options A*

#### **P45E 1-2E Area A&B Options A**

- 1 = Arm Button Required Before Code to Set (1=Area "A") (Default = 7,8)
- 2 = Stay Button Required Before Code to Set Stay Mode (2=Area "B")
- 3 = Code required to Set
- 4 = Code Required to Bypass Zones
- 5 = Spare
- 6 = Send Arm at the end of the Exit Delay
- 7 = Can Arm only if All Zones are Sealed (Ready)
- 8 = Can Arm Stay Mode only if All Zones are Sealed (Ready)

### *Area "A" & "B" Options B*

#### **P46E 1-2E Area A&B Options B**

- 1 = Use Near and Verified Alarm reporting for All zones in this Area (1=Area "A") (Default = All Off)
- 2 = Area will arm at end of time-zone (2=Area "B")
- 3 = Area will disarm at beginning of time-zone
- 4 = Assign Chirps to Access tags
- 5 = Spare
- 6 = Spare
- 7 = Spare
- 8 = Spare

### *Area "A" & "B" Arm Indication to Output*

#### **P47E 1-2E Area A&B Arm Indication to Output - Value 1-8 (for Outputs 1-8)**

- (1=Area "A") (Default = 3)
- (2=Area "B")

### *Area "A" & "B" Stay Arm Indication to Output*

#### **P48E 1-2E Area A&B Stay Arm Indication to Output - Value 1-8 (for Outputs 1-8)**

- (1=Area "A") (Default = 3)
- (2=Area "B")

### *Area "A" & "B" Disarm Indication to Output*

#### **P49E 1-2E Area A&B Disarm Indication to Output - Value 1-8 (for Outputs 1-8)**

- (1=Area "A") (Default = All Off)
- (2=Area "B")

### *Area "A" & "B" Pendant (or Access Tag) Arm Chirp to Output*

#### **P50E 1-2E Area A&B Arm Chirp to Output - Value 1-8 (for Outputs 1-8)**

- (1=Area "A") (Default = All Off) (One chirp to the output for arm)
- (2=Area "B")

***Area "A" & "B" Pendant (or Access Tag) Stay Arm Chirp to Output***

P51E 1-2E Area A&B Stay Arm Chirp to Output - Value 1-8 (for Outputs 1-8)  
(1=Area "A") (Default = All Off) (One chirp to the output for stay arm)  
(2=Area "B")

***Area "A" & "B" Pendant (or Access Tag) Disarm Chirp to Output***

P52E 1-2E Area A&B Disarm Chirp to Output - Value 1-8 (for Outputs 1-8)  
(1=Area "A") (Default = All Off) (Two chirps to the output for disarm)  
(2=Area "B")

***Area "A" & "B" Pendant Stay (or Access Tag) Disarm Chirp to Output***

P53E 1-2E Area A&B Stay Disarm Chirp to Output - Value 1-8 (for Outputs 1-8)  
(1=Area "A") (Default = All Off) (Two chirps to the output for disarm)  
(2=Area "B")

***Area "A" & "B" Arm Pulse to Output***

P54E 1-2E Area A&B Arm Pulse to Output - Value 1-8 (for Outputs 1-8)  
(1=Area "A") (Default = All Off)  
(2=Area "B")

***Area "A" & "B" Stay Arm Pulse to Output***

P55E 1-2E Area A&B Stay Arm Pulse to Output - Value 1-8 (for Outputs 1-8)  
(1=Area "A") (Default = All Off)  
(2=Area "B")

***Area "A" & "B" Disarm Pulse to Output***

P56E 1-2E Area A&B Disarm Pulse to Output - Value 1-8 (for Outputs 1-8)  
(1=Area "A") (Default = All Off)  
(2=Area "B")

***Area "A" & "B" Stay Disarm Pulse to Output***

P57E 1-2E Area A&B Stay Disarm Pulse to Output - Value 1-8 (for Outputs 1-8)  
(1=Area "A") (Default = All Off)  
(2=Area "B")

***Area "A" & "B" Armed Mode Exit Delay Beeps to Keypad***

P58E 1-2E Area A&B Armed Exit Delay Beeps to Keypad - Value 1-8 (for Keypads 1-8)  
(1=Area "A") (Default = All On)  
(2=Area "B")

***Area "A" & "B" Stay Mode Exit Delay Beeps to Keypad***

P59E 1-2E Area A&B Stay Exit Delay Beeps to Keypad - Value 1-8 (for Keypads 1-8)  
(1=Area "A") (Default = All off)  
(2=Area "B")

***Area "A" & "B" Armed Exit Delay Time***

P60E 1-2E Area A&B Exit Delay Time - Value 0-255 seconds  
(1=Area "A") (Default = 60 Seconds for Areas A&B)  
(2=Area "B")

***Area "A" & "B" Stay Armed Exit Delay Time***

P61E 1-2E Area A&B Stay Exit Delay Time - Value 0-255 seconds  
(1=Area "A") (Default = 60 Seconds for Areas A&B)  
(2=Area "B")

***Area "A" & "B" Monitoring Account Code Number***

P62E 1-2E Area A&B Account Code - Value 0000-FFFF  
(1=Area "A") (Default = 0000 for Areas A&B)  
(2=Area "B")

***Area "A" & "B" Remote "Command Control" Code Number***

P63E 1-2E Area A&B Command Control code - Value 1-4 digit code (1-9999)  
(1=Area "A") (Default = 0 for Areas A&B)  
(2=Area "B")

***Start Message Number for Areas "A" & "B" "Command Control"***

P64E 1-2E Start Message for Areas A&B Command Control - Value 0-99  
(1=Area "A") (Default = 0 for Areas A&B)  
(2=Area "B")

***Area "A" & "B" Armed Mode Exit Delay to Output***

P65E 1-2E Area A&B Armed Exit Delay to Output - Value 1-8 (for Outputs 1-8)  
(1=Area "A") (Default = All Off)  
(2=Area "B")

***Area "A" & "B" Stay Mode Exit Delay to Output***

P66E 1-2E Area A&B Stay Exit Delay to Output - Value 1-8 (for Outputs 1-8)  
(1=Area "A") (Default = All Off)  
(2=Area "B")

***Area "A" & "B" Delinquency Delay***

P67E 1-2E Area A&B Delinquency Delay - value 0-99 Days, (0 = Off)  
(1=Area "A") (Default = 0 for areas A&B)  
(2=Area "B")

***Area "A" & "B" Auto Arm/Disarm Time-zones***

P68E 1-2E Area A&B Auto Arm/Disarm Time-zones - Value 1-8 (for Time-zones 1-8)  
(1=Area "A") (Default = All Off) (2=Area "B")

# Keypads

## *Keypad Area Assignment*

P71E 1-8E Keypads Assigned To Areas

1 = Area "A" (Default = 1)

2 = Area "B"

## *Keypad Button Options*

P72E 1-8E Keypad Button Options

1 = <CHIME> or <CONTROL><PROGRAM> Button Enabled  
(Default = All 1-5)

2 = <BYPASS> Button Enabled

3 = <PANIC> Button Enabled

4 = Delayed panic on <PANIC> Button

5 = <1> & <3> Panic Alarm Enabled

6 = <4> & <6> Fire Alarm Enabled

7 = <7> & <9> Medical Alarm Enabled

8 = Spare

## *Alarm Beeps & LED Control to Keypad*

P73E 1-8E Keypad Beep/LED Options(Default = 5,8)

1 = Mains Fail Beeps Keypad Buzzer

2 = Fuse Failure Beeps Keypad Buzzer

3 = Battery Low Beeps Keypad Buzzer

4 = Telephone Line Failure Beeps Keypad Buzzer

5 = System Tamper Alarm Beeps Keypad Buzzer

6 = Receiver Fail Beeps Keypad Buzzer

7 = Turn Off Keypad LED's when Armed

8 = Turn Off Keypad & Backlight LED's on Mains Failure

### *Keypad "ARM" Button Area Assignment*

#### **P74E 1-8E Keypad "ARM" Button Area**

- 1 = "ARM" Button assigned to Area "A" (Default = 1)
- 2 = "ARM" Button assigned to Area "B"

### *Keypad "ARM" Button Area Options*

#### **P75E 1-8E Keypad "ARM" Button Opts.**

- 1 = "ARM" Button can Arm (Default = 1,7)
- 2 = "ARM" Button can Stay Mode Arm
- 3 = "ARM" Button can Disarm at All Times
- 4 = "ARM" Button can Disarm Stay Mode at All Times
- 5 = "ARM" Button can Reset Alarms
- 6 = "ARM" Button can Arm Latchkey Mode
- 7 = "ARM" Button can Disarm During Exit Delay
- 8 = "ARM" Button can Disarm Stay Mode During Exit Delay

### *Keypad "STAY" Button Area Assignment*

#### **P76E 1-8E Keypad "STAY" Button Area**

- 1 = "STAY" Button assigned to Area "A" (Default = 1)
- 2 = "STAY" Button assigned to Area "B"

### *Keypad "STAY" Button Area Options*

#### **P77E 1-8E Keypad "STAY" Button Opts.**

- 1 = "STAY" Button can Arm
- 2 = "STAY" Button can Stay Mode Arm (Default = 2,8)
- 3 = "STAY" Button can Disarm at All Times
- 4 = "STAY" Button can Disarm Stay Mode at All Times
- 5 = "STAY" Button can Reset Alarms
- 6 = "STAY" Button can Arm Latchkey Mode
- 7 = "STAY" Button can Disarm During Exit Delay
- 8 = "STAY" Button can Disarm Stay Mode During Exit Delay

### *Keypad "A" Button (Large LCD KP only) Area Assignment*

#### **P78E 1-8E Keypad "A" Button Area**

- 1 = "A" Button assigned to Area "A" (Default = 1)
- 2 = "A" Button assigned to Area "B"

### *Keypad "A" Button (Large LCD KP only) Area Options*

#### **P79E 1-8E Keypad "A" Button Opts.**

- 1 = "A" Button can Arm (Default = 1,7)
- 2 = "A" Button can Stay Mode Arm
- 3 = "A" Button can Disarm at All Times
- 4 = "A" Button can Disarm Stay Mode at All Times
- 5 = "A" Button can Reset Alarms
- 6 = "A" Button can Arm Latchkey Mode
- 7 = "A" Button can Disarm During Exit Delay
- 8 = "A" Button can Disarm Stay Mode During Exit Delay

### *Keypad "B" Button (Large LCD KP only) Area Assignment*

#### **P80E 1-8E Keypad "B" Button Area**

- 1 = "B" Button assigned to Area "A" (Default = none)
- 2 = "B" Button assigned to Area "B"

### *Keypad "B" Button (Large LCD KP only) Area Options*

#### **P81E 1-8E Keypad "B" Button Opts.**

- 1 = "B" Button can Arm (Default = 1,7)
- 2 = "B" Button can Stay Mode Arm
- 3 = "B" Button can Disarm at All Times
- 4 = "B" Button can Disarm Stay Mode at All Times
- 5 = "B" Button can Reset Alarms
- 6 = "B" Button can Arm Latchkey Mode
- 7 = "B" Button can Disarm During Exit Delay
- 8 = "B" Button can Disarm Stay Mode During Exit Delay

### *Keypad to Output Mask (for Access Control)*

#### **P82E 1-8E Keypad to Output Mask**

- 1 = The Keypad is linked to Output # 1 (Default = All On)
- 2 = The Keypad is linked to Output # 2
- 3 = The Keypad is linked to Output # 3
- 4 = The Keypad is linked to Output # 4
- 5 = The Keypad is linked to Output # 5
- 6 = The Keypad is linked to Output # 6
- 7 = The Keypad is linked to Output # 7
- 8 = The Keypad is linked to Output # 8

### *"Control" Button to Output Mask (for Access Control)*

#### **P83E 1-8E Keypad "Control" Button to Output Mask (Default = All On)**

- 1 = The Keypad "Control" Button is linked to Output # 1
- 2 = The Keypad "Control" Button is linked to Output # 2
- 3 = The Keypad "Control" Button is linked to Output # 3
- 4 = The Keypad "Control" Button is linked to Output # 4
- 5 = The Keypad "Control" Button is linked to Output # 5
- 6 = The Keypad "Control" Button is linked to Output # 6
- 7 = The Keypad "Control" Button is linked to Output # 7
- 8 = The Keypad "Control" Button is linked to Output # 8

### *"Panic" Button or "1&3" Alarm to Outputs*

#### **P84E 1-8E Keypad "Panic" Button or "1&3" Alarm to Outputs (Default = 1,2)**

- 1 = The Keypad "Panic" Button or "1&3" will turn on Output # 1
- 2 = The Keypad "Panic" Button or "1&3" will turn on Output # 2
- 3 = The Keypad "Panic" Button or "1&3" will turn on Output # 3
- 4 = The Keypad "Panic" Button or "1&3" will turn on Output # 4
- 5 = The Keypad "Panic" Button or "1&3" will turn on Output # 5
- 6 = The Keypad "Panic" Button or "1&3" will turn on Output # 6
- 7 = The Keypad "Panic" Button or "1&3" will turn on Output # 7
- 8 = The Keypad "Panic" Button or "1&3" will turn on Output # 8

### *"Fire (4&6)" Alarm to Outputs*

P85E 1-8E Keypad "Fire (4&6)" Alarm to Outputs (Default = none)

- 1 = The Keypad "Fire (4&6)" Alarm will turn on Output # 1
- 2 = The Keypad "Fire (4&6)" Alarm will turn on Output # 2
- 3 = The Keypad "Fire (4&6)" Alarm will turn on Output # 3
- 4 = The Keypad "Fire (4&6)" Alarm will turn on Output # 4
- 5 = The Keypad "Fire (4&6)" Alarm will turn on Output # 5
- 6 = The Keypad "Fire (4&6)" Alarm will turn on Output # 6
- 7 = The Keypad "Fire (4&6) Alarm "will turn on Output # 7
- 8 = The Keypad "Fire (4&6) Alarm "will turn on Output # 8

### *"Medical (7&9)" Alarm to Outputs*

P86E 1-8E Keypad "Medical (7&9)" Alarm to Outputs (Default = none)

- 1 = The Keypad "Medical (7&9)" Alarm will turn on Output # 1
- 2 = The Keypad "Medical (7&9)" Alarm will turn on Output # 2
- 3 = The Keypad "Medical (7&9)" Alarm will turn on Output # 3
- 4 = The Keypad "Medical (7&9)" Alarm will turn on Output # 4
- 5 = The Keypad "Medical (7&9)" Alarm will turn on Output # 5
- 6 = The Keypad "Medical (7&9)" Alarm will turn on Output # 6
- 7 = The Keypad "Medical (7&9)" Alarm will turn on Output # 7
- 8 = The Keypad "Medical (7&9)" Alarm will turn on Output # 8

### *"Duress" Alarm to Outputs*

P87E 1-8E Keypad "Duress" Alarm to Outputs (Default = All Off)

- 1 = The Keypad "Duress" Alarm will turn on Output # 1
- 2 = The Keypad "Duress" Alarm will turn on Output # 2
- 3 = The Keypad "Duress" Alarm will turn on Output # 3
- 4 = The Keypad "Duress" Alarm will turn on Output # 4
- 5 = The Keypad "Duress" Alarm will turn on Output # 5
- 6 = The Keypad "Duress" Alarm will turn on Output # 6
- 7 = The Keypad "Duress" Alarm will turn on Output # 7
- 8 = The Keypad "Duress" Alarm will turn on Output # 8

### *Keypad "Tamper Switch" Alarm to Outputs*

P88E 1-8E Keypad "Tamper Switch" Alarm to Outputs (Default = 1,2)

- 1 = The Keypad "Tamper Switch" Alarm will turn on Output # 1
- 2 = The Keypad "Tamper Switch" Alarm will turn on Output # 2
- 3 = The Keypad "Tamper Switch" Alarm will turn on Output # 3
- 4 = The Keypad "Tamper Switch" Alarm will turn on Output # 4
- 5 = The Keypad "Tamper Switch" Alarm will turn on Output # 5
- 6 = The Keypad "Tamper Switch" Alarm will turn on Output # 6
- 7 = The Keypad "Tamper Switch" Alarm will turn on Output # 7
- 8 = The Keypad "Tamper Switch" Alarm will turn on Output # 8

### *Keypad "Wrong Code" Alarm to Outputs*

P89E 1-8E Keypad "Wrong Code" Alarm to Outputs (Default = none)

- 1 = The Keypad "Wrong Code" Alarm will turn on Output # 1
- 2 = The Keypad "Wrong Code" Alarm will turn on Output # 2
- 3 = The Keypad "Wrong Code" Alarm will turn on Output # 3
- 4 = The Keypad "Wrong Code" Alarm will turn on Output # 4
- 5 = The Keypad "Wrong Code" Alarm will turn on Output # 5
- 6 = The Keypad "Wrong Code" Alarm will turn on Output # 6
- 7 = The Keypad "Wrong Code" Alarm will turn on Output # 7
- 8 = The Keypad "Wrong Code" Alarm will turn on Output # 8

### *Manually Operated Panic Alarm Beeps to Keypads*

P90E 1-8E Panic Alarm Beeps to Keypads (Default = All On)

- 1 = A Panic Alarm at the selected keypad will Beep KP # 1
- 2 = A Panic Alarm at the selected keypad will Beep KP # 2
- 3 = A Panic Alarm at the selected keypad will Beep KP # 3
- 4 = A Panic Alarm at the selected keypad will Beep KP # 4
- 5 = A Panic Alarm at the selected keypad will Beep KP # 5
- 6 = A Panic Alarm at the selected keypad will Beep KP # 6
- 7 = A Panic Alarm at the selected keypad will Beep KP # 7
- 8 = A Panic Alarm at the selected keypad will Beep KP # 8

### *Manually Operated Fire Alarm Beeps to Keypads*

P91E 1-8E Fire Alarm Beeps to Keypads (Default = All Off)

- 1 = A Fire Alarm at the selected keypad will Beep KP # 1
- 2 = A Fire Alarm at the selected keypad will Beep KP # 2
- 3 = A Fire Alarm at the selected keypad will Beep KP # 3
- 4 = A Fire Alarm at the selected keypad will Beep KP # 4
- 5 = A Fire Alarm at the selected keypad will Beep KP # 5
- 6 = A Fire Alarm at the selected keypad will Beep KP # 6
- 7 = A Fire Alarm at the selected keypad will Beep KP # 7
- 8 = A Fire Alarm at the selected keypad will Beep KP # 8

### *Manually Operated Medical Alarm Beeps to Keypads*

P92E 1-8E Medical Alarm Beeps to Keypads (Default = All Off)

- 1 = A Medical Alarm at the selected keypad will Beep KP # 1
- 2 = A Medical Alarm at the selected keypad will Beep KP # 2
- 3 = A Medical Alarm at the selected keypad will Beep KP # 3
- 4 = A Medical Alarm at the selected keypad will Beep KP # 4
- 5 = A Medical Alarm at the selected keypad will Beep KP # 5
- 6 = A Medical Alarm at the selected keypad will Beep KP # 6
- 7 = A Medical Alarm at the selected keypad will Beep KP # 7
- 8 = A Medical Alarm at the selected keypad will Beep KP # 8

### *Wrong Code or Keypad Tamper Switch Alarm Beeps to Keypads*

P93E 1-8E Wrong Code or Keypad Tamper Switch Alarm Beeps to Keypads  
(Default = All Off)

- 1 = A Wrong Code or KP Tamper Alarm at Keypad 1-8 will Beep KP # 1
- 2 = A Wrong Code or KP Tamper Alarm at Keypad 1-8 will Beep KP # 2
- 3 = A Wrong Code or KP Tamper Alarm at Keypad 1-8 will Beep KP # 3
- 4 = A Wrong Code or KP Tamper Alarm at Keypad 1-8 will Beep KP # 4
- 5 = A Wrong Code or KP Tamper Alarm at Keypad 1-8 will Beep KP # 5
- 6 = A Wrong Code or KP Tamper Alarm at Keypad 1-8 will Beep KP # 6
- 7 = A Wrong Code or KP Tamper Alarm at Keypad 1-8 will Beep KP # 7
- 8 = A Wrong Code or KP Tamper Alarm at Keypad 1-8 will Beep KP # 8

### *Chime Alarm Beep Time at a Keypad*

P94E 1-8E The Time the Chime Alarm will sound at Each Keypad - Value =0-255 1/10th sec  
(Default = 20 which is 2 Seconds)

### *Proximity Reader LED to Output Mapping*

P98E 1-8E Proximity Reader LED to Output Mapping (Default = None)

- 1 = Proximity Reader 1-8 LED will follow the state of Output # 1
- 2 = Proximity Reader 1-8 LED will follow the state of Output # 2
- 3 = Proximity Reader 1-8 LED will follow the state of Output # 3
- 4 = Proximity Reader 1-8 LED will follow the state of Output # 4
- 5 = Proximity Reader 1-8 LED will follow the state of Output # 5
- 6 = Proximity Reader 1-8 LED will follow the state of Output # 6
- 7 = Proximity Reader 1-8 LED will follow the state of Output # 7
- 8 = Proximity Reader 1-8 LED will follow the state of Output # 8

### *Learn Proximity Reader Keypad Address Number*

P99E 1-8E Learn Proximity Reader Keypad Address Number - Value = Keypad Address 1-8  
(Default = 20 which is 2 Seconds)

## Key-Switches

### *Key-switch Area Assignment*

P111E 1-2E K/S 1 & 2 assigned to Areas A or B -

1 = Assigned to Area "A" (1 = K/S # 1) (Default K/S # 1 = 1)

2 = Assigned to Area "B" (2 = K/S # 2) (Default K/S # 2 = 2)

### *Key-switch Access & Operational Options*

P112E 1-2E K/S 1 & 2 Access & Operational Options

1 = K/S can Arm Area (1 = K/S # 1) (Default = 1,3,8)

2 = K/S can arm Stay Mode (2 = K/S # 2)

3 = K/S can Disarm Area

4 = K/S can disarm Stay Mode

5 = K/S has Security Guard Options

6 = K/S will Arm Latchkey Mode

7 = Key-switch is N/O (If turned off the K/S is N/C)

8 = Key-switch is Momentary (If turned off the K/S is Latching)

## Zones

### *Programming Zones to Areas*

P121E 1-16E Assigning Zones to Areas A or B

1 = Assigned to Area "A" (Default = 1)

2 = Assigned to Area "B"

### *Programming Zone Options A*

#### **P122E 1-16E Programming Zone Options A**

- 1 = Zone is Active (Default Zone 1-8 = 1,6,7)
- 2 = Zone is N/O (Off = N/C) (Default Zone 9-16 =6,7)
- 3 = Spare
- 4 = Keypad Zone
- 5 = Zone is a Radio Zone
- 6 = Zone is a Stay Mode Zone
- 7 = Zone can be Manually Bypassed
- 8 = Zone can be Auto-Bypassed

### *Programming Zone Options B*

#### **P123E 1-16E Programming Zone Options B**

- 1 = Zone is a Handover Zone (Default = 1 for zone 2 only)
- 2 = Zone is a Two Trigger Zone
- 3 = Zone is a 24 Hour Zone
- 4 = Zone is a 24 Hour Auto-reset Zone
- 5 = Zone is a 24 Hour Fire Zone
- 6 = Zone is a One-Shot Zone
- 7 = Zone is a Chime Zone
- 8 = Zone is a Permanent Chime Zone

### *Programming Zone Options C*

#### **P124E 1-16E Programming Zone Options C**

( Default zones 1,2 = 1,2)

( Default zones 3-16 = 2)

- 1 = Can Arm if Zone is not Ready (Default = 2)
- 2 = Will Send Multiple Reports via Dialler
- 3 = Sensor-Watch Zone
- 4 = Zone is on Soak Test
- 5 = Zone will report to Area B Account Number
- 6 = Zone will Not Report 24 hour Alarms via Dialler
- 7 = Spare
- 8 = Spare

### *Programming Zone EOL (End-of-line) Options*

#### **P125E 1-8E Programming Zone EOL Options**

- 0 = Short Circuit** (Default = 0)
- 1 = 1k
- 2 = 1k5
- 3 = 2k2
- 4 = 3k3
- 5 = 3k9
- 6 = 4k7
- 7 = 5k6
- 8 = 6k8

- 9 = 10k
- 10 = 12k
- 11 = 22k
- 12 = 2k2 / 4k7
- 13 = 3k3 / 6k8
- 14 = 2k2 / 4k7 / 8k2
- 15 = 4k7 / 8k2

### *Programming Zone Response*

#### **P126E 1-8E Programming Zone Response**

1 to 8 Vibration mode (Default = 9)  
(Zone EOL-P125E, for Vibration Mode MUST be type 3 only) 1 = highest and 8 is lowest sensitivity level.

9 to 26 Normal zone mode Response time = approx 200ms –1sec

### *Programming the Radio Zone Detector Type*

#### **P127E 1-16E Programming the Radio Zone Type from the List - Value = 1-35 (Default = 3)**

- 0 = Generic
- 1 = Crow Merlin PIR (supervised signal ignored)
- 2 = Crow Merlin PIR (supervised signal active)
- 3 = Freelink with checksum (supervised signal active)
- 4 = Freelink with checksum (non-supervised)
- 5 = Crow AE Series Battery low
- 6 = Crow AE Radio Reed Switch
- 11 = Ness Devices battery Low
- 12 = Ness Radio Reed Switch
- 21 = Electronics Line Radio PIR
- 31 = Visonic K900 Radio PIR
- 32 = Visonic Powercode (supervised signal ignored)
- 33 = Visonic Powercode (supervised signal active)
- 34 = Siemens (supervised signal ignored)
- 35 = Siemens (supervised signal active)

### *Armed Zone Alarms to Outputs*

#### **P128E 1-16E Armed Zone Alarms to Output (Default = 1,2)**

- 1 = A Zone Alarm will Turn On Output # 1
- 2 = A Zone Alarm will Turn On Output # 2
- 3 = A Zone Alarm will Turn On Output # 3
- 4 = A Zone Alarm will Turn On Output # 4
- 5 = A Zone Alarm will Turn On Output # 5
- 6 = A Zone Alarm will Turn On Output # 6
- 7 = A Zone Alarm will Turn On Output # 7
- 8 = A Zone Alarm will Turn On Output # 8

### *Armed Stay Mode Zone Alarms to Outputs*

#### **P129E 1-16E Armed Stay Mode Zone Alarms to Output** (Default = 1,2)

- 1 = A Stay Mode Zone Alarm will Turn On Output # 1
- 2 = A Stay Mode Zone Alarm will Turn On Output # 2
- 3 = A Stay Mode Zone Alarm will Turn On Output # 3
- 4 = A Stay Mode Zone Alarm will Turn On Output # 4
- 5 = A Stay Mode Zone Alarm will Turn On Output # 5
- 6 = A Stay Mode Zone Alarm will Turn On Output # 6
- 7 = A Stay Mode Zone Alarm will Turn On Output # 7
- 8 = A Stay Mode Zone Alarm will Turn On Output # 8

### *24 Hour Zone Alarms to Outputs*

#### **P130E 1-16E 24 Hour Zone Alarms to Output** (Default = 1,2)

- 1 = A 24 Hour Zone Alarm will Turn On Output # 1
- 2 = A 24 Hour Zone Alarm will Turn On Output # 2
- 3 = A 24 Hour Zone Alarm will Turn On Output # 3
- 4 = A 24 Hour Zone Alarm will Turn On Output # 4
- 5 = A 24 Hour Zone Alarm will Turn On Output # 5
- 6 = A 24 Hour Zone Alarm will Turn On Output # 6
- 7 = A 24 Hour Zone Alarm will Turn On Output # 7
- 8 = A 24 Hour Zone Alarm will Turn On Output # 8

### *Chime Zone Alarms to Outputs*

#### **P131E 1-16E Chime Zone Alarms to Output** (Default = All Off)

- 1 = A Chime Zone Alarm will Turn On Output # 1
- 2 = A Chime Zone Alarm will Turn On Output # 2
- 3 = A Chime Zone Alarm will Turn On Output # 3
- 4 = A Chime Zone Alarm will Turn On Output # 4
- 5 = A Chime Zone Alarm will Turn On Output # 5
- 6 = A Chime Zone Alarm will Turn On Output # 6
- 7 = A Chime Zone Alarm will Turn On Output # 7
- 8 = A Chime Zone Alarm will Turn On Output # 8

### *Zone Tamper Alarms to Outputs*

#### **P132E 1-16E Zone Tamper Alarms to Output** (Default = 1,2)

- 1 = A Zone Tamper Alarm will Turn On Output # 1
- 2 = A Zone Tamper Alarm will Turn On Output # 2
- 3 = A Zone Tamper Alarm will Turn On Output # 3
- 4 = A Zone Tamper Alarm will Turn On Output # 4
- 5 = A Zone Tamper Alarm will Turn On Output # 5
- 6 = A Zone Tamper Alarm will Turn On Output # 6
- 7 = A Zone Tamper Alarm will Turn On Output # 7
- 8 = A Zone Tamper Alarm will Turn On Output # 8

### *Armed Zone Alarm Beeps to Keypads*

**P134E 1-16E Armed Zone Alarm Beeps to Keypads** (Default = 1,2,3,4,5,6,7,8)

- 1 = An Armed Zone Alarm will Beep Keypad #1
- 2 = An Armed Zone Alarm will Beep Keypad #2
- 3 = An Armed Zone Alarm will Beep Keypad #3
- 4 = An Armed Zone Alarm will Beep Keypad #4
- 5 = An Armed Zone Alarm will Beep Keypad #5
- 6 = An Armed Zone Alarm will Beep Keypad #6
- 7 = An Armed Zone Alarm will Beep Keypad #7
- 8 = An Armed Zone Alarm will Beep Keypad #8

### *Stay Mode Zone Alarm Beeps to Keypads*

**P135E 1-16E Stay Mode Zone Alarm Beeps to Keypads** (Default = 1,2,3,4,5,6,7,8)

- 1 = A Stay Mode Zone Alarm will Beep Keypad #1
- 2 = A Stay Mode Zone Alarm will Beep Keypad #2
- 3 = A Stay Mode Zone Alarm will Beep Keypad #3
- 4 = A Stay Mode Zone Alarm will Beep Keypad #4
- 5 = A Stay Mode Zone Alarm will Beep Keypad #5
- 6 = A Stay Mode Zone Alarm will Beep Keypad #6
- 7 = A Stay Mode Zone Alarm will Beep Keypad #7
- 8 = A Stay Mode Zone Alarm will Beep Keypad #8

### *24 Hour Zone Alarm Beeps to Keypads*

**P136E 1-16E 24 Hour Zone Alarm Beeps to Keypads** (Default = 1,2,3,4,5,6,7,8)

- 1 = A 24 Hour Zone Alarm will Beep Keypad #1
- 2 = A 24 Hour Zone Alarm will Beep Keypad #2
- 3 = A 24 Hour Zone Alarm will Beep Keypad #3
- 4 = A 24 Hour Zone Alarm will Beep Keypad #4
- 5 = A 24 Hour Zone Alarm will Beep Keypad #5
- 6 = A 24 Hour Zone Alarm will Beep Keypad #6
- 7 = A 24 Hour Zone Alarm will Beep Keypad #7
- 8 = A 24 Hour Zone Alarm will Beep Keypad #8

### *Chime Zone Alarm Beeps to Keypads*

**P137E 1-16E Chime Zone Alarm Beeps to Keypads** (Default = 1,2,3,4,5,6,7,8)

- 1 = A Chime Zone Alarm will Beep Keypad #1
- 2 = A Chime Zone Alarm will Beep Keypad #2
- 3 = A Chime Zone Alarm will Beep Keypad #3
- 4 = A Chime Zone Alarm will Beep Keypad #4
- 5 = A Chime Zone Alarm will Beep Keypad #5
- 6 = A Chime Zone Alarm will Beep Keypad #6
- 7 = A Chime Zone Alarm will Beep Keypad #7
- 8 = A Chime Zone Alarm will Beep Keypad #8

### *Zone Tamper Alarm Beeps to Keypads*

**P139E 1-16E Zone Tamper Alarm Beeps to Keypads** (Default = 1,2,3,4,5,6,7,8)

- 1 = A Zone Tamper Alarm will Beep Keypad #1
- 2 = A Zone Tamper Alarm will Beep Keypad #2
- 3 = A Zone Tamper Alarm will Beep Keypad #3
- 4 = A Zone Tamper Alarm will Beep Keypad #4
- 5 = A Zone Tamper Alarm will Beep Keypad #5
- 6 = A Zone Tamper Alarm will Beep Keypad #6
- 7 = A Zone Tamper Alarm will Beep Keypad #7
- 8 = A Zone Tamper Alarm will Beep Keypad #8

### *Radio Supervise Alarm Beeps to Keypads*

**P140E 1-16E Radio Supervise Alarm Beeps to Keypads** (Default = All On)

- 1 = A Radio Supervise Alarm will Beep Keypad #1
- 2 = A Radio Supervise Alarm will Beep Keypad #2
- 3 = A Radio Supervise Alarm will Beep Keypad #3
- 4 = A Radio Supervise Alarm will Beep Keypad #4
- 5 = A Radio Supervise Alarm will Beep Keypad #5
- 6 = A Radio Supervise Alarm will Beep Keypad #6
- 7 = A Radio Supervise Alarm will Beep Keypad #7
- 8 = A Radio Supervise Alarm will Beep Keypad #8

### *Zone Sensor-watch Alarm Beeps to Keypads*

**P141E 1-16E Zone Sensor-watch Alarm Beeps to Keypads** (Default = All On)

- 1 = A Zone Sensor-watch Alarm will Beep Keypad #1
- 2 = A Zone Sensor-watch Alarm will Beep Keypad #2
- 3 = A Zone Sensor-watch Alarm will Beep Keypad #3
- 4 = A Zone Sensor-watch Alarm will Beep Keypad #4
- 5 = A Zone Sensor-watch Alarm will Beep Keypad #5
- 6 = A Zone Sensor-watch Alarm will Beep Keypad #6
- 7 = A Zone Sensor-watch Alarm will Beep Keypad #7
- 8 = A Zone Sensor-watch Alarm will Beep Keypad #8

### *Armed Zone Entry Delay Beeps to Keypads*

**P142E 1-16E Armed Zone Entry Delay Beeps to Keypads** (Default = 1,2,3,4,5,6,7,8)

- 1 = Armed Zone Entry Delay will Beep Keypad #1
- 2 = Armed Zone Entry Delay will Beep Keypad #2
- 3 = Armed Zone Entry Delay will Beep Keypad #3
- 4 = Armed Zone Entry Delay will Beep Keypad #4
- 5 = Armed Zone Entry Delay will Beep Keypad #5
- 6 = Armed Zone Entry Delay will Beep Keypad #6
- 7 = Armed Zone Entry Delay will Beep Keypad #7
- 8 = Armed Zone Entry Delay will Beep Keypad #8

### *Stay Mode Entry Delay Beeps to Keypads*

**P143E 1-16E Stay Mode Entry Delay Beeps to Keypads** (Default = 1,2,3,4,5,6,7,8)

- 1 = Stay Mode Entry Delay will Beep Keypad #1
- 2 = Stay Mode Entry Delay will Beep Keypad #2
- 3 = Stay Mode Entry Delay will Beep Keypad #3
- 4 = Stay Mode Entry Delay will Beep Keypad #4
- 5 = Stay Mode Entry Delay will Beep Keypad #5
- 6 = Stay Mode Entry Delay will Beep Keypad #6
- 7 = Stay Mode Entry Delay will Beep Keypad #7
- 8 = Stay Mode Entry Delay will Beep Keypad #8

### *Armed Zone Entry Delay Times*

**P144E 1-16E Armed Zone Entry Delay Times** - Value 0-9999 seconds

(Default Zone # 1,2 = 20 Seconds, Zones # 3-16 = 0)

### *Stay Mode, Lockout & 4+2 Reporting Codes*

#### *Stay Mode Entry Delay Times*

**P145E 1-16E Stay Mode Entry Delay Times** - Value 0-9999 seconds

(Default Zones # 1-2 = 20 Seconds, Zones # 3-16 = 0)

#### *Zone Lockout (re-trigger) Times*

**P146E 1-16E Zone Re-Trigger Times** - Value 0-255 minutes

(Default = 0 Minutes)

#### *Zone Alarm 4+2 Reporting Codes*

**P147E 1-16E Zone Alarm 4+2 Reporting Code** - Two digit value from 00-FF

#### *Zone Alarm 4+2 Restore Reporting Codes*

**P148E 1-16E Zone Alarm Restore 4+2 Code** - Two digit value from 00-FF

#### *Zone Near Alarm 4+2 Reporting Codes*

**P149E 1-16E Zone Near Alarm 4+2 Reporting Code** - Two digit value from 00-FF

#### *Zone Near Alarm 4+2 Restore Reporting Codes*

**P150E 1-16E Zone Near Alarm Restore 4+2 Code** - Two digit value from 00-FF

#### *Zone Intrusion Verified Alarm 4+2 Reporting Codes*

**P151E 1-16E Zone Intrusion Verified Alarm 4+2 Reporting Code** - Two digit value from 00-FF

#### *Zone Intrusion Verified Alarm 4+2 Restore Reporting Codes*

**P152E 1-16E Zone Intrusion Verified Alarm Restore 4+2 Code** - Two digit value from 00-FF

#### *Zone Bypass Alarm 4+2 Reporting Codes*

**P155E 1-16E Zone Bypass Alarm 4+2 Reporting Code** - Two digit value from 00-FF

#### *Zone Bypass 4+2 Restore Reporting Codes*

**P156E 1-16E Zone Bypass Restore 4+2 Code** - Two digit value from 00-FF

## Alarm CID Reporting Codes

### *Zone Alarm Contact ID Reporting Codes*

**P157E 1-16E Zone Alarm Contact ID Reporting Code** - (Default = 130)

### *Zone Near Alarm Contact ID Reporting Codes*

**P158E 1-16E Zone Near Alarm Contact ID Reporting Code** - (Default = 138)

### *Zone Intrusion Verified Alarm Contact ID Reporting Codes*

**P159E 1-16E Zone Intrusion Verified Alarm Contact ID Reporting Code** - (Default = 139)

### *Zone Alarm Voice Message Number*

**P160E 1-16E Zone Alarm Voice Message Number** - Value-0-99 (Default = 1)

## Entry Delay to Outputs

### *Away Zone Entry Delay to Outputs*

**P161E 1-16E Away Zone Entry Delay to Outputs** (Default = All Off)

- 1 = Armed Zone Entry Delay to output #1
- 2 = Armed Zone Entry Delay to output #2
- 3 = Armed Zone Entry Delay to output #3
- 4 = Armed Zone Entry Delay to output #4
- 5 = Armed Zone Entry Delay to output #5
- 6 = Armed Zone Entry Delay to output #6
- 7 = Armed Zone Entry Delay to output #7
- 8 = Armed Zone Entry Delay to output #8

### *Stay Mode Entry Delay to Outputs*

**P162E 1-16E Stay Mode Entry Delay Beeps to Outputs** (Default = All Off)

- 1 = Stay Mode Entry Delay to output #1
- 2 = Stay Mode Entry Delay to output #2
- 3 = Stay Mode Entry Delay to output #3
- 4 = Stay Mode Entry Delay to output #4
- 5 = Stay Mode Entry Delay to output #5
- 6 = Stay Mode Entry Delay to output #6
- 7 = Stay Mode Entry Delay to output #7
- 8 = Stay Mode Entry Delay to output #8

## Watch-Dog Timer

### *Sensor-Watch Timer*

**P163E 1-16E Sensor-Watch Timer** - 0-9999 Minutes (Default = 7200 minutes [120 Hours])

## Radio Codes

### *Enrolling Radio Zone Codes*

P164E 1-16E Learn Radio Zone Codes

### *Delete a Specific Radio Zone Code*

P165E 1-16E Delete a Specific Radio Zone Code

### *Find Radio Zone Memory Location*

P166E 0E This will find the zone # of any Radio Zone code stored in the panel  
Only press 0E when using LED Keypad.

## Time Zones

### *Programming Holidays*

P170E 1-8E Holidays 1-8 Days - Value = DDMMYY

### *Programming Time Zone Days*

P171E 1-8E Time Zones 1-8 Days Default = All Off)

- 1 = Sunday
- 2 = Monday
- 3 = Tuesday
- 4 = Wednesday
- 5 = Thursday
- 6 = Friday
- 7 = Saturday
- 8 = Invert

### *Programming Time Zone Start & End Times*

**P172E 1-8E Time Zones 1-8 Start Time** - Value 0000-2359 (Default = 0000)

**P173E 1-8E Time Zones 1-8 End Time** - Value 0000-2359 (Default = 0000) Page 77

### *Time Zone Options*

P174E 1-8E Time Zone 1-8 Options (Default = All Off)

- 1 = Ignore Holidays
- 2-8 = Spare

## Dialler

### *Dialler Programming Options*

- P175E 1E Dialler options (Default = 1,2,7)
- 1 = Dialler is Enabled
  - 2 = Fax Defeat
  - 3 = Disable Telephone Line Monitoring
  - 4 = DTMF or Pulse Dial (For DTMF, 4&5 must both be OFF)
  - 5 = DTMF or Reverse Pulse Dial (For DTMF, 4&5 must both be OFF)
  - 6 = Send long DTMF tones during dialing
  - 7 = Auto Detect Modem Mode
  - 8 = Bell 103 or V21

### *Dialler Programming Options 2*

- P175E 2E Dialler options 2 (Default = 1)
- 1 = Step number on each call
  - 2 = Upload/Download use callback
  - 3 = Upload/Download only if disarmed
  - 4 = Test calls only if armed
  - 5 = Spare
  - 6 = Hold line open following Domestic/Voice report for DTMF control
  - 7 = First to Open Last to Close Reporting
  - 8 = Spare

### *Auto-Answer Ring Count*

- P175E 3E Auto-Answer Ring Count - Value 0-99 (Default = 8)

### *Time to the First Dialler Test Call*

- P175E 4E Time to the First Dialler Test Call - Value 0000-2359 (Default = 2300)

### *Test Call Time Period*

- P175E 5E **Test Time Call Period** - Value 0-255 Hours: 0 = No Test (Default = 24)

### *Keypad Listen-in Options*

- P175E 6E Keypad Listen-in Options (Default = 1,2,3,4,5,6,7)
- 1 = Enabled During Dialling in Disarm State only
  - 2 = Enabled During Dialling in Armed State only
  - 3 = Enabled During Dialling in Stay Mode State only
  - 4 = Enabled Throughout the call in Disarm State only
  - 5 = Enabled Throughout the call in Armed State only
  - 6 = Enabled Throughout the call in Stay Mode State only
  - 7 = Listen-in Enabled when the panel answers a call
  - 8 = Enabled at All Times

### *Output # 1 Listen-in Options*

- P175E 7E      Output # 1 Listen-in Options (Default = All Off)
- 1 = Enabled During Dialling in Disarm State only
  - 2 = Enabled During Dialling in Armed State only
  - 3 = Enabled During Dialling in Stay Mode State only
  - 4 = Enabled Throughout the call in Disarm State only
  - 5 = Enabled Throughout the call in Armed State only
  - 6 = Enabled Throughout the call in Stay Mode State only
  - 7 = Listen-in Enabled when the panel answers a call
  - 8 = Enabled at All Times

### *Dialling Pre-fix Number*

- P175E 8E      Dialling Pre-fix Number - Value 1-16 Digits (Default = 0)

### *“Panic” Alarm Contact ID Reporting Code*

- P175E 9E      “Panic” Alarm CID Reporting Code - (Default=120)

### *“Fire” Alarm Contact ID Reporting Code*

- P175E 10E     “Fire” Alarm CID Reporting Code - (Default=110)

### *“Medical” Alarm Contact ID Reporting Code*

- P175E 11E     “Medical” Alarm CID Reporting Code - (Default=100)

### *Output “Command Control” Code Number*

- P175E 12E     Output Command Control code - Value 1-4 digit code (1-9999) (Default = 0)

### *Microphone On/Off “Command Control” Code Number*

- P175E 13E     Microphone Command Control code - Value 1-4 digit code (1-9999) (Default = 0)

### *Dialler Acknowledge Code*

- P175E 14E     Voice/Domestic Acknowledge Code - Value 1-4 digit code (1-9999) (Default = 0)

### *Force Test Call Code*

- P175E 15E     Force Test Call Code - Value 1-4 digit code (1-9999) (Default = 0, Feature disabled)

### *Programming Voice Board Messages*

- P176E 1E Keypad or Radio "Panic" Alarm Voice Message Number - Value 0-99 (Default = 1)
- P176E 2E "Fire" Alarm Voice Message Number - Value 0-99 (Default = 1)
- P176E 3E "Medical" Alarm Voice Message Number - Value 0-99 (Default = 1)
- P176E 4E "Mains Failure" Voice Message Number - Value 0-99 (Default = 1)
- P176E 5E "Mains Restore" Voice Message Number - Value 0-99 (Default = 1)
- P176E 6E "Battery Low" Voice Message Number - Value 0-99 (Default = 1)
- P176E 7E "Battery Restored" Voice Message Number - Value 0-99 (Default = 1)
- P176E 8E "Tamper" (Zone/Radio/System) Voice Message Number - Value 0-99 (Default = 1)
- P176E 9E "Duress Alarm" Voice Message Number - Value 0-99 (Default = 1)
- P176E 10E "Latchkey Disarm" Voice Message Number - Value 0-99 (Default = 1)
- P176E 11E "Manual Test Initiated" Voice Message Number - Value 0-99 (Default = 1)

## Telephone Numbers

### *Programming Telephone Numbers*

- P181E 1-8E Programming Telephone Numbers - Value 1-16 Digits (Default = 0)

### *Telephone Number Reporting Formats*

- P182E 1-8E Telephone Number Reporting Formats (Default = 2)
  - 1 = Contact ID
  - 2 = Domestic Dial
  - 3 = Pager
  - 4 = Speech Dialler
  - 5 = 4+2 10pps (Handshake 1400/ Tone 1900)
  - 6 = 4+2 10pps (Handshake 2300/ Tone 1800)
  - 7 = 4+2 20pps (Handshake 1400/ Tone 1900)
  - 8 = 4+2 20pps (Handshake 2300/ Tone 1800)
  - 9 = 4+2 DTMF (with Checksum)

### *Telephone Number Reporting Options*

P183E 1-8E Telephone Number Reporting Options (Default = 2,6)

- 1 = Stop Dialling if Kissed off
- 2 = Monitor Call Progress
- 3 = Blind Dial
- 4 = Use Group Numbers for Contact ID Reporting
- 5 = Spare
- 6 = Auto Kiss-off for Voice/Domestic Reporting
- 7 = Use the Dialling Pre-fix
- 8 = Is to be used as the "Call-back" Number

### *Maximum Dial Attempts per Telephone Number*

P184E 1-8E Maximum Dial Attempts per Telephone Number - Value 0-99 (Default = 3)

### *Dialler Reporting Options A*

**P186E 1-8E Dialler Options A**

- 1 = Report Mains Failure (Default = 1,2,3,4,5,6,7,8)
- 2 = Report Battery low
- 3 = Report Radio Battery Low
- 4 = Report Line Fail
- 5 = Report System Tamper
- 6 = Report Keypad Tamper
- 7 = Report Zone Tamper
- 8 = Report Radio Zone Tamper

### *Dialler Reporting Options B*

**P187E 1-8E Dialler Options B**

- 1 = Report Duress Alarm (Default = 1,2,3,4,5,6,7,8)
- 2 = Report Supervised Radio Alarm
- 3 = Report Zone Sensor-watch Alarm
- 4 = Report Manual Panic Alarm
- 5 = Report Manual Fire Alarm
- 6 = Report Manual Medical Alarm
- 7 = Report Radio Pendant Panic Alarm
- 8 = Report Zone Bypasses

### *Dialler Reporting Options C*

**P188E 1-8E Dialler Options C**

- 1 = Report Arm/Disarm (Default = 1,2,5,7,8)
- 2 = Report Stay Mode Arm/Disarm
- 3 = Report Disarm only after an Activation
- 4 = Report Stay Mode Disarm only after an Activation
- 5 = Report Stay Mode Zone Alarms
- 6 = Report Access to Program Mode
- 7 = Report 24 Hour Alarms when set to Domestic/Voice mode
- 8 = Report Zone Restores

### *Dialler Reporting Options D*

#### **P189E 1-8E Dialler Options D**

- 1 = Report Latchkey Disarm (Default = 3,4,5)
- 2 = Report Delinquent
- 3 = Report Tests
- 4 = Report Fuse Failure
- 5 = Report Output 1 or 2 Fail
- 6 = Spare
- 7 = Spare
- 8 = Spare

### *Divert Area Events*

#### **P192E 1-2E Divert Area Events (1=Area A) (Default = All Off)**

- 1 = Dial on away arm
- 2=Area B) 2 = Dial on away disarm
- 3 = Dial on stay arm
- 4 = Dial on stay disarm
- 5 = Dial if Key-switch activation
- 6 = Dial if Time zone activation
- 7 = Dial if DTMF or PC activation
- 8 = Dial if keypad "ARM" or "STAY" single button activation

### *Divert Number Options*

#### **P193E 1-2E Divert Numbers Options (1=Divert on) (Default = All Off)**

- 1 = Spare (2=Divert off)
- 2 = Spare
- 3 = Blind Dial
- 4 = Spare
- 5 = Spare
- 6 = Spare
- 7 = Use the Dialling Pre-fix
- 8 = Spare

### *Divert Numbers*

#### **P194E 1-2E Divert Numbers - Value 1-16 Digits (Default = 0)**

- (1=Divert on)
- (2=Divert off)

## Miscellaneous 4+2 Program Options

### *Mains & Battery 4+2 Reporting Codes*

- P195E 1E      **Mains Failure 4+2 Code** - Two digit value from 00-FF  
 P195E 2E      **Mains Failure restore 4+2 Code** - Two digit value from 00-FF  
 P195E 3E      **Low Battery 4+2 Code** - Two digit value from 00-FF  
 P195E 4E      **Low Battery Restore 4+2 Code** - Two digit value from 00-FF

### *System Tamper 4+2 Reporting Codes*

- P195E 5E      4+2 Alarm Code for System Tamper - Two digit value from 00-FF  
 P195E 6E      4+2 Alarm Code for System Tamper Restore - Two digit value from 00-FF  
 Page 89

### *Remote Arm/Disarm 4+2 Reporting Codes*

- P195E 7E      4+2 Code for Remote Arming (Full Arm or Stay Mode Arm)- Two digit value from 00-FF  
 Page 89  
 P195E 8E      4+2 Code for Remote Disarm - Two digit value from 00-FF

### *Duress Alarm 4+2 Reporting Code*

- P195E 9E      4+2 Duress Alarm Code - Two digit value from 00-FF

### *Automatic Test 4+2 Reporting Code*

- P195E 10E      4+2 Automatic Test Code - Two digit value from 00-FF

### *Armed by "Arm" Button 4+2 Reporting Code*

- P195E 11E      4+2 Arm by "Arm" Button Code - Two digit value from 00-FF

### *Stay Mode Arming 4+2 Reporting Code*

- P195E 12E      4+2 Stay Mode Arming Code - Two digit value from 00-FF

### *Disarmed by "Arm" or "Stay" Button 4+2 Reporting Code*

- P195E 13E      4+2 Disarm by Arm or Stay Button - Two digit value from 00-FF

### *Armed/Disarmed by "Key-switch" 4+2 Reporting Code*

- P195E 14E      4+2 Arm by "Key-switch" Code - Two digit value from 00-FF  
 P195E 15E      4+2 Disarm by "Key-switch" Code - Two digit value from 00-FF

### *"Time Zone Arm Failure" 4+2 Reporting Code*

- P195E 16E      4+2 Time Zone Arm Failure - Two digit value from 00-FF

### *Keypad "Panic" Alarm 4+2 Reporting Code*

- P195E 17E      Keypad Panic Alarm 4+2 Code - Two digit value from 00-FF

### *Keypad "Panic" Alarm 4+2 Restore Reporting Code*

- P195E 18E      Keypad Panic Alarm Restore 4+2 Code - Two digit value from 00-FF

### *Keypad "Fire" Alarm 4+2 Reporting Code*

- P195E 19E      Keypad Fire Alarm 4+2 Code - Two digit value from 00-FF

### *Keypad "Fire" Alarm 4+2 Restore Reporting Code*

- P195E 20E      Keypad Fire Alarm Restore 4+2 Code - Two digit value from 00-FF

*Keypad "Medical" Alarm 4+2 Reporting Code*

P195E 21E Keypad Medical Alarm 4+2 Code - Two digit value from 00-FF

*Keypad "Medical" Alarm 4+2 Restore Reporting Code*

P195E 22E Keypad Medical Alarm Restore 4+2 Code - Two digit value from 00-FF

## Panel Diagnostic & Default Options

*Display Panel Software Version Number*

P200E 1E Display the Panel Software Version Number

*Display Keypad Address Number*

P200E 2E Display Keypad Address Number

*Display Areas Assigned to this Keypad*

P200E 3E Display Areas Assigned to this Keypad

*Display Active Time Zones*

P200E 4E Display Active Time Zones

*Display Battery Voltage*

P200E 5E Display Battery Voltage

*Walk Test Mode*

P200E 6E Walk Test Mode

*Write to EEPROM (DTU) Board*

P200E 7E Write to EEPROM (DTU) Board

*Read from EEPROM (DTU) Board*

P200E 8E Read from EEPROM (DTU) Board

*Restore User & Installer Codes plus Telephone Numbers to Defaults*

P200E 9E Restore User/Installer Codes & Telephone #'s to Default Values

*Restore All Factory Defaults*

P200E 10E Restore All Factory Defaults

*Clear Alarm Memory Buffer*

P200E 11E Clear Alarm Memory Buffer

*Initiate a Call to the Call-back*

P200E 12E Initiate a Call to the Call-back

## CROW ELECTRONIC ENGINEERING LTD. (Crow) WARRANTY POLICY CERTIFICATE

This Warranty Certificate is given in favor of the purchaser (hereunder the "**Purchaser**") purchasing the products directly from Crow or from its authorized distributor.

Crow warrants these products to be free from defects in materials and workmanship under normal use and service for a period of 24 months from the last day of the week and year whose numbers are printed on the printed circuit board inside these products (hereunder the "**Warranty Period**").

Subject to the provisions of this Warranty Certificate, during the Warranty Period, Crow undertakes, at its sole discretion and subject to Crow's procedures, as such procedures are from time to time, to repair or replace, free of charge for materials and/or labor, products proved to be defective in materials or workmanship under normal use and service. Repaired products shall be warranted for the remainder of the original Warranty Period.

All transportation costs and in-transit risk of loss or damage related, directly or indirectly, to products returned to Crow for repair or replacement shall be borne solely by the Purchaser.

Crow's warranty under this Warranty Certificate does not cover products that is defective (or shall become defective) due to: (a) alteration of the products (or any part thereof) by anyone other than Crow; (b) accident, abuse, negligence, or improper maintenance; (c) failure caused by a product which Crow did not provide; (d) failure caused by software or hardware which Crow did not provide; (e) use or storage other than in accordance with Crow's specified operating and storage instructions.

There are no warranties, expressed or implied, of merchantability or fitness of the products for a particular purpose or otherwise, which extend beyond the description on the face hereof.

This limited Warranty Certificate is the Purchaser's sole and exclusive remedy against Crow and Crow's sole and exclusive liability toward the Purchaser in connection with the products, including without limitation - for defects or malfunctions of the products. This Warranty Certificate replaces all other warranties and liabilities, whether oral, written, (non-mandatory) statutory, contractual, in tort or otherwise.

In no case shall Crow be liable to anyone for any consequential or incidental damages (inclusive of loss of profit, and whether occasioned by negligence of the Crow or any third party on its behalf) for breach of this or any other warranty, expressed or implied, or upon any other basis of liability whatsoever. Crow does not represent that these products can not be compromised or circumvented; that these products will prevent any person injury or property loss or damage by burglary, robbery, fire or otherwise; or that these products will in all cases provide adequate warning or protection.

Purchaser understands that a properly installed and maintained product may in some cases reduce the risk of burglary, fire, robbery or other events occurring without providing an alarm, but it is not insurance or a guarantee that such will not occur or that there will be no personal injury or property loss or damage as a result.

Consequently, Crow shall have no liability for any personal injury; property damage or any other loss based on claim that these products failed to give any warning.

If Crow is held liable, whether directly or indirectly, for any loss or damage with regards to these products, regardless of cause or origin, Crow's maximum liability shall not in any case exceed the purchase price of these products, which shall be the complete and exclusive remedy against Crow.

# How to Contact Us

## **ISRAEL:**

12 Kineret St., P.O.B 293,  
Airport-City,  
Lod, 70100.

Tel: 972-3-9726000

Fax: 972-3-9726001

E-mail:  
[support@crow.co.il](mailto:support@crow.co.il)

## **ITALY:**

DEATRONIC  
VIA Giulianello 4/14  
00178 ROMA, ITALY

Tel: +39-0676-12912

Fax: +39-0676-12601

E-mail:  
[info@deatronic.com](mailto:info@deatronic.com)

## **USA:**

2160 North Central Road,  
Fort Lee, N.J. 07024

Tel: 1-800-GET CROW

(201) 944 0005

Fax: (201) 944 1199

E-mail:  
[support@crowelec.com](mailto:support@crowelec.com)

## **LATIN AMERICA:**

CROW LATIN AMERICA  
5753 NW 151<sup>ST</sup>.Street  
MIAMI LAKES,

FL 33014 – USA

Tel: +1-305-823-8700

Fax: +1-305-823-8711

E-mail:  
[sales@crowlatinamerica.com](mailto:sales@crowlatinamerica.com)

## **AUSTRALIA:**

429 Nepean HWY Brighton  
East Vic 3187

Tel: 61-3-9596 7222

Fax: 61-3-9596 0888

E-mail:  
[crow@crowaust.com.au](mailto:crow@crowaust.com.au)

## **POLAND:**

VIDICON SP. ZO. O.  
15 Povazkowska St.

01 – 797 Warsaw

Tel: 48 22 562 3000

Fax: 48 22 562 3030

E-mail:  
[vidicon@vidicon.pl](mailto:vidicon@vidicon.pl)